

**RESOLUTION NO. 18-38**

**A RESOLUTION OF THE CITY OF PANAMA CITY BEACH, FLORIDA AUTHORIZING THE ISSUANCE OF ITS FIRE SERVICE ASSESSMENT REVENUE NOTE, SERIES 2018, IN THE PRINCIPAL AMOUNT OF NOT TO EXCEED \$604,319 TO FUND THE ACQUISITION AND/OR CONSTRUCTION OF CERTAIN CAPITAL IMPROVEMENTS AND EQUIPMENT OF THE CITY; PROVIDING THAT THE SERIES 2018 NOTE SHALL BE A LIMITED OBLIGATION OF THE CITY PAYABLE SOLELY FROM CERTAIN SPECIAL ASSESSMENTS AS PROVIDED HEREIN; PROVIDING FOR THE RIGHTS AND REMEDIES FOR THE OWNER OF THE SERIES 2018 NOTE; MAKING CERTAIN COVENANTS AND AGREEMENTS IN CONNECTION THEREWITH; AND PROVIDING FOR AN EFFECTIVE DATE.**

**BE IT RESOLVED BY THE CITY COUNCIL OF THE CITY OF PANAMA CITY BEACH, FLORIDA:**

**SECTION 1. AUTHORITY.** This Resolution is adopted pursuant to the provisions of Article VIII, Section 2 of the Constitution of the State of Florida, Chapter 166, Florida Statutes, the Charter of the City of Panama City Beach, Florida, the Assessment Ordinance, the Assessment Resolution, and other applicable provisions of law.

**SECTION 2. DEFINITIONS.** All capitalized words and terms not otherwise defined herein shall have the meanings set forth in the Assessment Resolution, unless the context herein otherwise requires. Unless the context indicates otherwise, words

importing the singular number include the plural number, and vice versa. The following words and phrases shall have the following meanings when used herein:

"**Act**" means Article VIII, Section 2 of the Constitution of the State of Florida, Chapter 166, Florida Statutes, the Charter of the Issuer, the Assessment Ordinance and other applicable provisions of law.

"**Additional Notes**" means additional obligations issued in compliance with the terms, conditions and limitations contained in Section 13 hereof which will have an equal lien on the Pledged Revenues, to the extent herein provided and rank equally in all other respects with the Series 2018 Note and other Additional Notes issued hereunder.

"**Annual Debt Service Requirement**" means the principal and interest on the Notes coming due in the forthcoming Fiscal Year.

"**Assessment Ordinance**" means Ordinance No. 1444 adopted by the Issuer prior to the adoption of the Assessment Resolution.

"**Assessment Resolution**" means Resolution No. 18-37 adopted by the Issuer prior to the adoption of this Resolution.

"**Business Day**" means any day except any Saturday or Sunday or day on which the principal office of the Owner of a Note is closed.

"**City Attorney**" means the City Attorney, or any special counsel to the Issuer, or such other counsel as may be duly authorized by the City Council to act on its behalf.

"**Clerk**" means the City Clerk or assistant or deputy City Clerk of the Issuer, or such other Person as may be duly authorized by the City Council of the Issuer to act on his or her behalf.

"**Code**" means the Internal Revenue Code of 1986, as amended, and any Treasury Regulations, whether temporary, proposed or final, promulgated thereunder or applicable thereto.

"**Debt Service Fund**" means the Debt Service Fund established herein with respect to the Series 2018 Note.

"**Fire Service Assessments**" means the special assessments, sometimes referred to as non-ad valorem assessments, imposed and collected by the Issuer pursuant to the Assessment Ordinance and any assessment resolution provided for therein.

"**Fiscal Year**" means the period commencing on October 1 of each year and continuing through the following September 30, or such other period as may be prescribed by law as the Fiscal Year for the Issuer.

"**Issuer**" means the City of Panama City Beach, Florida, a municipal corporation of the State of Florida

"**Mayor**" means the Mayor of the Issuer or in his or her absence or inability to act, the Vice Mayor of the Issuer or such other Person as may be duly authorized by the City Council to act on his or her behalf.

"**Notes**" means the Series 2018 Note and any outstanding Additional Notes.

**"Owner"** means the Person in whose name a Series 2018 Note shall be registered on the books of the Issuer kept for that purpose in accordance with provisions of this Resolution.

**"Original Purchaser"** means the original purchaser of the Series 2018 Note.

**"Person"** means natural persons, firms, trusts, estates, associations, corporations, partnerships and public bodies.

**"Pledged Revenues"** means (1) the Fire Service Assessments; (2) the monies on deposit in the Debt Service Fund and the Project Fund established herein, and (3) investment earnings on moneys on deposit in such funds.

**"Project"** means the acquisition and/or construction of capital improvements and equipment for the Issuer's fire protection services including, without limitation, the construction of fire stations and the acquisition of equipment necessary for the suppression of and from fires (including, but not limited to, fire engines or trucks) permitted to be funded with the proceeds of any Notes pursuant to the laws of the State.

**"Project Fund"** means the Project Fund to be established pursuant to Section 10 hereof with respect to the Series 2018 Note.

**"Resolution"** means this Resolution, pursuant to which the Series 2018 Note is authorized to be issued, including any Supplemental Resolutions.

**"Series 2018 Note"** means the Issuer's Fire Service Assessment Revenue Note, Series 2018, authorized by Section 4 hereof.

**"State"** means the State of Florida.

**"Supplemental Resolution"** means any resolution of the Issuer amending, supplementing or restating this Resolution.

### **SECTION 3. FINDINGS.**

(A) For the benefit of its inhabitants and property owners, and in order to maintain a continual state of preparedness to address fire incidents, the City Council finds, determines and declares that it is necessary for the continued preservation of the health, welfare, convenience and safety of its inhabitants and in the best interests of the property owners within the jurisdiction of the Issuer to acquire and/or construct the Project. Issuance of the Series 2018 Note to finance the Project satisfies a paramount public purpose.

(B) Debt service on the Notes will be payable from a pledge of the Pledged Revenues as provided herein. The Pledged Revenues will be sufficient to pay the principal and interest on the Series 2018 Note herein authorized, as the same become due, and to make all deposits required by this Resolution.

(C) The Issuer shall never be required to exercise any ad valorem taxing power or use any ad valorem tax revenues to pay such Series 2018 Note, nor shall any Owner be entitled to payment of such Series 2018 Note from any funds of the Issuer

except from the Pledged Revenues as described herein. The Series 2018 Note shall not constitute a lien upon any properties owned or located within the boundaries of the Issuer or upon any property other than the Pledged Revenues.

**SECTION 4. AUTHORIZATION OF PROJECT AND SERIES 2018 NOTE;  
THIS RESOLUTION TO CONSTITUTE CONTRACT.**

(A) The Issuer does hereby authorize the Project. Subject and pursuant to the provisions of this Resolution, an Obligation of the Issuer to be known as City of Panama City Beach, Florida, Fire Service Assessment Revenue Note, Series 2018 (the "Series 2018 Note") is hereby authorized to be issued under and secured by the Pledged Revenues pursuant to this Resolution, in the principal amount of not to exceed \$604,319 for the Project. Notwithstanding anything herein to the contrary, the series designation applicable to the Series 2018 Note may be changed to conform to the calendar year of issue.

(B) In consideration of the acceptance of any Notes authorized to be issued hereunder by those who shall hold the same from time to time, this Resolution shall be deemed to be and shall constitute a contract between the Issuer and the Owner. The covenants and agreements herein set forth to be performed by the Issuer shall be for the equal benefit, protection and security of the legal Owner of any and all of the Notes, all of which shall be of equal rank and without preference, priority or distinction of any of the Notes over any other thereof, except as expressly provided therein and herein.

**SECTION 5. DESCRIPTION OF NOTES; EXECUTION OF NOTES.** The

Notes shall be dated the date of their respective execution and delivery, which shall be a date agreed upon by the Issuer and the Original Purchaser. The Notes constitute Obligations of the Issuer and may, if and when authorized by the Issuer pursuant to this Resolution and any Supplemental Resolution, be issued in one or more Series, with such further appropriate particular designations added to or incorporated in such title for the Notes of any particular series as the Issuer may determine. The Notes shall bear interest at such rate or rates not exceeding the maximum rate permitted by law as provided in the Supplemental Resolution; and shall be payable and/or prepayable in lawful money of the United States of America on such dates all as determined herein or by Supplemental Resolution. The Notes may bear interest at fixed or variable rates and may be issued as current interest notes, capital appreciation notes, lease purchase obligations subject to annual appropriation or other legal structures as approved by Supplemental Resolution. The Notes shall be in the form set forth by Supplemental Resolution.

**SECTION 6. REGISTRATION AND EXCHANGE OF PERSONS**

**TREATED AS OWNER.** The Person in whose name the Notes shall be registered shall be deemed and regarded as the absolute Owner and payment of principal and interest on such Note shall be made only to or upon the written order of the Owner. All such

payments shall be valid and effectual to satisfy and discharge the liability upon such Note to the extent of the sum or sums so paid.

**SECTION 7. PAYMENT OF PRINCIPAL AND INTEREST; LIMITED OBLIGATION.** The Issuer promises that it will promptly pay the principal of and interest on the Notes at the place, on the dates and in the manner provided herein and by Supplemental Resolution according to the true intent and meaning hereof and thereof. The Notes shall not be or constitute a general obligation or indebtedness of the Issuer as a “bond” within the meaning of Article VII, Section 12 of the Constitution of Florida, but shall be payable solely from the Pledged Revenues in accordance with the terms hereof. No holder of any Note issued hereunder shall ever have the right to compel the exercise of any ad valorem taxing power or the use of ad valorem tax revenues to pay such Notes, or be entitled to payment of such Notes from any funds of the Issuer except from the Pledged Revenues as described herein.

**SECTION 8. DEBT SERVICE FUND.**

(A) The Issuer hereby covenants that it will establish with a depository in the State of Florida, which is eligible under the laws of the State of Florida to receive municipal funds, a fund to be known as the “City of Panama City Beach, Florida, Fire Service Assessment Revenue Note, Series 2018 Debt Service Fund” (the “Debt Service Fund”).



(B) Upon receipt, the Issuer shall deposit all proceeds of the Fire Service Assessments, after payment of any collection costs and administration costs associated therewith (whether collected by use of the Tax Collector, Property Appraiser, or otherwise), into the Debt Service Fund until such time as moneys sufficient to pay the Annual Debt Service Requirement for the then current Fiscal Year are on deposit therein.

(C) Upon deposit of an amount equal to the Annual Debt Service Requirement in any Fiscal Year, no further deposits shall be made into the Debt Service Fund and the remaining Fire Service Assessments shall be transferred to the general fund or other appropriate fund of the Issuer and shall be used for any lawful purpose and shall no longer be considered Pledged Revenues hereunder.

(D) Moneys on deposit in the Debt Service Fund shall be used solely to pay the principal of and interest on the Notes as it becomes due.

**SECTION 9. PLEDGE AND COLLECTION OF PLEDGED REVENUES.**

(A) The principal of and interest on the Notes will be secured solely by a lien upon and pledge of the Pledged Revenues.

(B) Equally and ratably, the Issuer does hereby irrevocably pledge and grant a lien on the Pledged Revenues, prior and superior to all other liens and encumbrances on such Pledged Revenues, to the payment of principal of and interest on the Notes in accordance with the provisions hereof. The Pledged Revenues shall immediately be

subject to the lien of this pledge without any physical delivery thereof or further act, and the lien of this pledge shall be valid and binding as against all parties having claims of any kind in tort, contract or otherwise against the Issuer, irrespective of whether such parties have notice thereof.

(C) The Issuer covenants to do all things necessary on its part to collect the Fire Service Assessments, and will take all steps, actions and proceedings for the enforcement and collection of such Fire Service Assessments as shall become delinquent to the full extent permitted or authorized by law; and will maintain accurate records with respect thereof. All such Fire Service Assessments, as collected, be held in trust to be applied as herein provided. The Issuer will not amend or modify the resolutions pursuant to which the Fire Service Assessments are assessed so as to impair or adversely affect the power and obligation of the Issuer to assess such Pledged Revenues.

(D) The Issuer shall annually and timely adopt an assessment resolution as required and necessary for imposing Fire Service Assessments for each Fiscal Year in an amount sufficient to satisfy the Annual Debt Service Requirement until the Notes have been paid in full.

**SECTION 10. APPLICATION OF PROCEEDS OF SERIES 2018 NOTE;  
PROJECT FUND.**

(A) At the time of delivery of the Series 2018 Note, proceeds from the sale of the Series 2018 Note shall be used to reimburse and/or pay the Project Costs and associated costs of issuance (including, but not limited to, legal and financial advisory fees and expenses) in accordance with the provisions in this Section.

(B) The Issuer hereby covenants that it will establish with a depository in the State of Florida, which is eligible under the laws of the State of Florida to receive municipal funds, one fund to be known as the "City of Panama City Beach, Florida, Fire Service Assessment Revenue Note, Series 2018, Project Fund" (the "Project Fund").

(C) Proceeds from the sale of the Series 2018 Note herein authorized shall be deposited into the Project Fund and shall be used as described herein. When the acquisition and/or construction of the Project has been completed and all Project Costs and costs of issuance have been paid in full, all funds remaining in the Project Fund shall be used to prepay the outstanding balance of the Series 2018 Note corresponding to the Project and the Project Fund shall be closed. All moneys deposited in said Project Fund shall be and constitute a trust fund created for the purposes herein stated, and there is hereby created a lien upon such fund in favor of the holders of the Series 2018 Note until the moneys thereof shall have been applied in accordance with this Resolution.

(D) Moneys on deposit from time to time in the Project Fund shall be used to pay or reimburse the following Project Costs:

(1) Costs incurred directly or indirectly for or in connection with a Project or a proposed or future Project or acquisition including, but not limited to, those for preliminary planning and studies, architectural, construction management services, legal, financial, engineering and supervisory services, labor, services, materials, equipment, accounts receivable, acquisitions, land, rights-of-way, improvements and installation;

(2) Premiums attributable to all insurance required to be taken out and maintained during the period of construction with respect to a Project to be acquired or constructed, the premium on each surety bond, if any, required with respect to work on such facilities, and taxes, assessments and other charges hereof that may become payable during the period of construction with respect to such a Project;

(3) Costs incurred directly or indirectly in seeking to enforce any remedy against a contractor or subcontractor in respect of any default under a contract relating to a Project or costs incurred directly or indirectly in defending any claim by a contractor or subcontractor with respect to a Project;

(4) Financial, legal, accounting, appraisals, title evidence and printing and engraving fees, charges and expenses, and all other such fees, charges and

expenses incurred in connection with the authorization, sale, issuance and delivery of such Notes;

(5) Capitalized interest funded from Note proceeds, if any, for a reasonable period of time;

(6) Any other incidental and necessary costs including without limitation any expenses, fees and charges relating to the acquisition, construction or installation of a Project, and the making of extraordinary repairs, renewals and replacements, decommissioning or retirement of any portion of the Project, including the cost of temporary employees of the Issuer retained to carry out duties in connection with the acquisition, construction or erection of a Project and costs related to transition of such Project into ownership by the Issuer;

(7) Costs incurred directly or indirectly in placing any Project in operation in order that completion of such Project may occur;

(8) Any other costs relating to the Project authorized pursuant to a Supplemental Resolution of the Issuer and permitted under the laws of the State; and

(9) Reimbursements to the Issuer for any of the above items hereinbefore paid by or on behalf of the Issuer.

(E) Notwithstanding anything else in this Resolution to the contrary, in the Event of Default, the trustee acting for the holders of Notes shall, to the extent there are

no other available funds held hereunder, use the remaining funds the Project Fund to pay principal and interest on the Notes.

**SECTION 11. SPECIAL FUNDS.**

(A) The funds created and established by this Resolution shall constitute trust funds for the purpose provided herein for such funds. All of such funds shall be continuously secured in the same manner as municipal deposits of funds are required to be secured by the laws of the State of Florida. Moneys on deposit to the credit of all funds created hereunder may be invested pursuant to applicable law and the Issuer's investment policy and, shall mature not later than the dates on which such moneys shall be needed to make payments in the manner herein provided. The securities so purchased as an investment of funds shall be deemed at all times to be a part of the fund from which the said investment was withdrawn, and the interest accruing thereon, and any profit realized therefrom shall be credited to such fund, and any loss resulting from such investment shall likewise be charged to said fund.

(B) The moneys required to be accounted for in each of the foregoing funds and accounts established herein may be deposited in a single bank account, and funds allocated to the various funds and accounts established herein may be invested in a common investment pool, provided that adequate accounting records are maintained to reflect and control the restricted allocation of the moneys on deposit therein and such investments for the various purposes of such funds and accounts as herein provided.

(C) The designation and establishment of the various funds and accounts in and by this Resolution shall not be construed to require the establishment of any completely independent, self-balancing funds as such term is commonly defined and used in governmental accounting, but rather is intended solely to constitute an earmarking of certain revenues for certain purposes and to establish certain priorities for application of such revenues as herein provided.

**SECTION 12. TAX COVENANT.** The Issuer covenants to the Owner of the Notes provided for in this Resolution that the Issuer will not make any use of the proceeds of the Notes at any time during the term of the Notes which, if such use had been reasonably expected on the date the Note was issued, would have caused such Note to be an “arbitrage bond” within the meaning of the Code. The Issuer will comply with the requirements of the Code and any valid and applicable rules and regulations promulgated thereunder necessary to ensure the exclusion of interest on the Note from the gross income of the holders thereof for purposes of federal income taxation.

**SECTION 13. ADDITIONAL NOTES.**

(A) The Issuer will not issue any Obligations payable from the Fire Service Assessments or voluntarily create or cause to be created any debt, lien, pledge, assignment, encumbrance or other charge having priority to or being on a parity with the lien of any Note issued pursuant to this Resolution upon the Pledged Revenues except under the terms and conditions and in the manner provided herein. Any

Obligations issued by the Issuer other than in accordance with this Section and payable from the Fire Service Assessments shall contain an express statement that such Obligations are junior and subordinate in all respects to the Notes issued hereunder as to lien on, and source of and security for payment from, the Pledged Revenues.

(B) No Additional Notes may be issued hereunder unless the Mayor shall sign and issue a certificate that shall state and certify that the Fire Service Assessments for the most recently audited Fiscal Year of the Issuer preceding the issuance of Additional Notes equaled at least one (1) times the maximum Annual Debt Service Requirement for Notes then outstanding and on the Additional Notes proposed to be issued.

(C) Each Resolution or enabling instrument authorizing the issuance of such Additional Notes will recite that all of the covenants herein contained will be fully applicable to such Additional Notes as if originally issued hereunder.

**SECTION 14. LIMITATION OF RIGHTS.** With the exception of any rights herein expressly conferred, nothing expressed or mentioned in or to be implied from this Resolution or the Notes is intended or shall be construed to give to any Person other than the Issuer and the Owner any legal or equitable right, remedy or claim under or with respect to this Resolution or any covenants, conditions and provisions herein contained; this Resolution and all of the covenants, conditions and provisions hereof



being intended to be and being for the sole and exclusive benefit of the Issuer and the Owner.

**SECTION 15. AMENDMENT; IMPAIRMENT OF CONTRACT.** This Resolution shall not be modified or amended in any respect subsequent to the issuance of the Notes except with the written consent of the Owner of the Note. The Issuer covenants with the Owner of the Note that it will not, without the written consent of the Owner of the Note adopt any resolution which repeals, impairs or amends in any manner adverse to the Owner the rights granted to the Owner of the Note hereunder.

**SECTION 16. EVENTS OF DEFAULT; REMEDIES OF OWNER.**

(A) The following shall constitute "Events of Default": (i) if the Issuer fails to pay any payment of principal of or interest on any Note as the same becomes due and payable; (ii) if the Issuer defaults in the performance or observance of any covenant or agreement contained in this Resolution or the Note (other than set forth in (i) above) and fails to cure the same within thirty (30) days after written notice to the Issuer by the Owner; or (iii) filing of a petition by or against the Issuer relating to bankruptcy, reorganization, arrangement or readjustment of debt of the Issuer or for any other relief relating to the Issuer under the United States Bankruptcy Code, as amended, or any other insolvency act or law now or hereafter existing, or the involuntary appointment of a receiver or trustee for the Issuer, and the continuance of any such event for 90 days undismitted or undischarged.

(B) Any Owner of the Note may either at law or in equity, by suit, action, mandamus or other proceedings in any court of competent jurisdiction, protect and enforce any and all rights, including the right to the appointment of a receiver, existing under the Laws of the State of Florida, or granted and contained in this Resolution, and may enforce and compel the performance of all duties required by this Resolution or by any applicable State or Federal statutes to be performed by the Issuer or by any officer thereof. Nothing herein, however, shall be construed to grant to any Owner of the Note any lien on any real property of the Issuer.

**SECTION 17. SEVERABILITY.** If any provision of this Resolution shall be held or deemed to be or shall, in fact, be illegal, inoperative or unenforceable in any context, the same shall not affect any other provision herein or render any other provision (or such provision in any other context) invalid, inoperative or unenforceable to any extent whatever.

**SECTION 18. APPLICABLE PROVISIONS OF LAW.** This Resolution shall be governed by and construed in accordance with the laws of the State.

**SECTION 19. MEMBERS OF THE CITY COUNCIL OF THE ISSUER EXEMPT FROM PERSONAL LIABILITY.** No recourse under or upon any obligation, covenant or agreement of this Resolution or the Notes or for any claim based thereon or otherwise in respect thereof, shall be had against any member of the City Council of the Issuer, as such, past, present or future, either directly or through the

Issuer it being expressly understood (1) that no personal liability whatsoever shall attach to, or is or shall be incurred by, the members of the City Council of the Issuer, as such, under or by reason of the obligations, covenants or agreements contained in this Resolution or implied therefrom, and (2) that any and all such personal liability, either at common law or in equity or by constitution or statute, of, and any and all such rights and claims against, every such member of the City Council of the Issuer, as such, are waived and released as a condition of, and as a consideration for, the execution of this Resolution and the issuance of the Notes, on the part of the Issuer.

**SECTION 20. AUTHORIZATIONS.** The Mayor and any member of the City Council, the City Manager, the City Attorney, the Clerk and such other officials, employees and agents of the Issuer as may be designated by the Issuer are each designated as agents of the Issuer in connection with the issuance and delivery of the Series 2018 Note and are authorized and empowered, collectively or individually, to take all action and steps and to execute all instruments, documents, and contracts on behalf of the Issuer that are necessary or desirable in connection with the execution and delivery of the Series 2018 Note, and which are specifically authorized or are not inconsistent with the terms and provisions of this Resolution.

**SECTION 21. SALE OF NOTES.** The Notes may be issued and sold at public or private sale at one time or in installments from time to time and at such price or prices as shall be consistent with the provisions of the requirements of this

Resolution, as further approved by a Supplemental Resolution and other applicable provisions of law.

**SECTION 22. VALIDATION.** The City Attorney and any special counsel authorized by the Council are hereby directed and authorized to institute appropriate proceedings for the validation pursuant to Chapter 75, Florida Statutes, of the Series 2018 Note and any and all matters connected therewith or other proceedings necessary for the Issuer to determine its authority to issue the Series 2018 Note, construct and/or acquire the Project, including the validity and use of the Pledged Revenues in all respects, and the proper officers of the Issuer are hereby authorized to verify on behalf of the Issuer any pleadings in such proceedings.

**SECTION 23. DECLARATION OF INTENT.** The Issuer hereby expresses its intention to be reimbursed from proceeds of a future tax-exempt financing for expenditures to be paid by the Issuer in connection with the Project. Pending reimbursement, the Issuer has used or may use funds on deposit in its general fund to pay Project Costs. It is reasonably expected that the total amount of debt to be incurred by the Issuer with respect to the Project will not exceed \$604,319. This Resolution is intended to constitute a “declaration of official intent” within the meaning of Section 1.150-2 of the Code with respect to the Project.

**SECTION 24. REPEALER.** All resolutions or parts thereof in conflict herewith are hereby repealed.

**SECTION 25. EFFECTIVE DATE.** This Resolution shall be in force and take effect immediately upon its passage and adoption by the City Council.

**PASSED and ADOPTED** in regular session of the City Council of the City of Panama City Beach, Florida, this 11<sup>th</sup> day of January 2018.

**PANAMA CITY BEACH CITY COUNCIL**

By:   
Mike Thomas, Mayor

ATTEST:

  
Jo Smith, City Clerk

## Jo Smith

---

**From:** Larry Couch <[lcouch@pcbfire.com](mailto:lcouch@pcbfire.com)>  
**Sent:** Thursday, January 4, 2018 4:52 PM  
**To:** Mark Lawson; Amy E. Myers  
**Subject:** Fwd: Fire Apparatus Information  
**Attachments:** PCBFR Saber POL 1.4.18.pdf; PCB Saber Drawing1.4.18.pdf; Lease Estimator.pdf

Fire information

Larry Couch  
Fire Chief  
Panama City Beach Fire Rescue

Begin forwarded message:

**From:** "McAtee, Rob" <[rmcatee@ten8fire.com](mailto:rmcatee@ten8fire.com)>  
**Date:** January 4, 2018 at 4:46:43 PM CST  
**To:** Larry Couch <[lcouch@pcbfire.com](mailto:lcouch@pcbfire.com)>  
**Subject:** Fire Apparatus Information

Chief,

Attached to this email is an options list (POL) for one (1) Pierce Saber FR pumper. Also attached is a rough computer generated drawing, as well as a lease purchase estimate created on the Lease Estimator.

The LIST cost of one (1) pumper is \$535,845.00. Using the Florida Sheriff's Association (FSA) consortium and purchasing more than one (1) apparatus will result in additional discounts.

If the City decides to go the lease purchase path; just multiply the annual lease payments by the term and add the end of term payment on the attached Lease Estimator to obtain the estimated total revenue outlay for such an obligation; or,  $(\$86,331.09 \times 7 \text{ years}) + 1.00 = \$604,318.63$ .

If there is anything else that I can do, please feel free to contact me. Thank-you for your interest; I'm always here for you.

Rob McAtee  
Pierce Fire Apparatus  
Ten-8 Fire Equipment  
850-276-3247



# Proposal Option List

1/4/2018

<b>Customer:</b>		<b>Bid Number:</b>	858
<b>Representative:</b>	McAtee, Rob	<b>Job Number:</b>	
<b>Organization:</b>	Ten-8 Fire Equipment, Inc	<b>Number of Units:</b>	
<b>Requirements Manager:</b>		<b>Bid Date:</b>	
<b>Description:</b>	City of Panama City Beach Fire Rescue	<b>Stock Number:</b>	
<b>Body:</b>	Pumper, Medium, Aluminum, 2nd Gen, Saber/Commercial	<b>Price Level:</b>	36 (Current: 36)
<b>Chassis:</b>	Saber FR Chassis		

Line	Option	Type	Option Description	Qty
1	0074080		Build-to-Order, Pierce Florida Product - 2nd Gen Pumper	1
2	0671399		Boiler Plates, Pumper	1
			Fire Department/Customer - Panama City Beach Fire Rescue	
			Operating/In conjunction W-Service Center - Operating	
			Miles - 50 Miles	
			Number of Fire Dept/Municipalities - 2	
			Bidder/Sales Organization - Ten-8 Fire Equipment	
			Delivery - Delivery representative	
			Dealership/Sales Organization, Service - Ten-8 Fire Equipment	
3	0661794		Single Source Compliance	1
4	0584455		Manufacture Location: Bradenton, Florida	1
5	0584453		RFP Location: Bradenton, Florida	1
6	0588609		Vehicle Destination, US	1
7	0610784		Comply NFPA 1901 Changes Effective Jan 1, 2016, With Exceptions	1
8	0533347		Pumper/Pumper with Aerial Device Fire Apparatus	1
9	0588611		Vehicle Certification, Pumper	1
10	0568412		Agency, Apparatus Certification, Pumper/Tanker, Third Party, PMFD	1
11	0537375		Unit of Measure, US Gallons	1
12	0529326		Bid Bond, 10%, Pierce Built Chassis	1
13	0540326		Performance Bond, Not Requested	1
14	0000007		Approval Drawing	1
15	0002928		Electrical Diagrams	1
16	0632451		Saber FR Chassis	1
17	0629024		Chassis Discount, Saber FR	1
18	0000110		Wheelbase	1
			Wheelbase - 225.00	
19	0000070		GVW Rating	1
			GVW rating - 45,000	
20	0649713		Frame Rails, 10.25" x 3.50" x .375", Saber FR/Enf	1
21	0648354		Frame Liner, Internal "C", 9.38" x 3.13" x .25", Saber FR/Enf, 26" Qval	1
22	0635815		Axle, Front, Dana, D-2000F, 18,000 lb Saber FR/Enforcer	1
23	0637879		Suspension, Front, Standens, Taper Leaf, 18,000 lb, Saber FR/Enforcer	1
24	0000321		Shock Absorbers on Front Axle, Monroe Magnum 65, Saber/Enforcer	1
25	0000322		Oil Seals, Front Axle	1
26	0011637		Tires, Front, Goodyear, G291, 315/80R22.50, 20 ply	1
27	0019575		Wheels, Front, Alcoa, 22.50" x 9.00", Aluminum, Hub Pilot	1
28	0640711		Axle, Rear, Dana S26-190, 27,000 lb Saber/Enforcer	1
29	0544253		Top Speed of Vehicle, 68 MPH	1
30	0565380		Suspen, Rear, Single Slipper Spring, 27,000 lb, Saber/Enforcer	1
31	0000485		Oil Seals, Rear Axle	1
32	0587216		Tires, Rear, Goodyear, G622 RSD, 12R22.50, 16 ply, Single	1
33	0019625		Wheels, Rear, Alcoa, 22.50" x 8.25", Aluminum, Hub Pilot, Single	1
34	0568081		Tire Balancing, Counteract Beads	1
35	0620570		Tire Pressure Monitoring, RealWheels, AirSecure, Valve Cap, Single Axle	1
			Qty, Tire Pressure Ind - 6	
36	0003245		Axle Hub Covers w/center hole, S/S, Front Axle	1
37	0001960		Axle Hub Covers, Rear, S/S, High Hat (Pair)	1
38	0057936		Covers, Lug Nut, Chrome	1
39	0002045		Mud Flaps, w/logo front & rear	1

Line	Option	Type	Option Description	Qty
40	0544802		Chocks, Wheel, SAC-44-E, Folding Qty, Pair - 01	1
41	0544806		Mounting Brackets, Chocks, SAC-44-E, Folding, Horizontal Qty, Pair - 01 Location, Wheel Chocks - Left Side Rear Compt	1
42	0010670		ABS Wabco Brake System, Single rear axle	1
43	0690932		Brakes, Bendix, ADB22X, 17" Disc, Front	1
44	0627930		Brakes, Bendix, Cam, Rear, 16.50 x 8.63"	1
45	0020784		Air Compressor, Brake, Cummins/Wabco 18.7 CFM	1
46	0644232		Brake Reservoirs, 4,272 Cubic Inch Minimum Capacity, Saber FR/Enforcer	1
47	0644228		Air Dryer, Wabco System Saver 1200 IWT, Heated, Saber FR/Enforcer	1
48	0000790		Brake Lines, Nylon	1
49	0000854		Air Inlet, w/Disconnect Coupling Location, Air Coupling(s) - a) DS Step Well, Forward Qty, Air Coupling (s) - 1	1
50	0795472		Engine, Cummins L9, 450 hp, 1250 lb-ft, W/OBD, EPA 2017, Saber FR/Enforcer	1
51	0001244		High Idle w/Electronic Engine, Custom	1
52	0687994		Engine Brake, Jacobs Compression Brake, Cummins Engine Switch, Engine Brake - e) ISC/ISM/ISL9/ISX Hi Med Lo	1
53	0644227		Clutch, Fan, Air Actuated, Saber FR/Enforcer	1
54	0640477		Air Intake, Metal Screen, Saber FR/Enforcer	1
55	0794761		Exhaust System, 4", 2017 L9 Engine, Horizontal, Right Side	1
56	0788765		Radiator, Saber FR/Enforcer	1
57	0001090		Cooling Hoses, Rubber	1
58	0001125		Fuel Tank, 65 Gallon, Left Side Fill	1
59	0001129		Lines, Fuel	1
60	0662965		DEF Tank, 4.5 Gallon, DS Fill, Rear of Axle, Common Air Bottle Door	1
61	0552793		Not Required, Fuel Priming Pump	1
62	0552712		Not Required, Shutoff Valve, Fuel Line	1
63	0699437		Cooler, Chassis Fuel, Not Req'd.	1
64	0642572		Trans, Allison 5th Gen, 3000 EVS P, w/Prognostics, Imp/Vel/DCF/SFR/Enf	1
65	0625329		Transmission, Shifter, 5-Spd, Push Button, 3000 EVS	1
66	0684459		Transmission Oil Cooler, Modine, External	1
67	0001370		Driveline, Spicer 1710	1
68	0635294		Steering, Single Gear, TRW TAS-85, w/tilt, Pump w/ Cooler, Saber FR/Enforcer	1
69	0605356		Steering Wheel, 4 Spoke without Controls, Saber FR/Enforcer	1
70	0690274		Logo/Emblem, on Dash Text, Row (1) One - PCBFR Text, Row (2) Two - Engine Text, Row (3) Three - XX	1
71	0012245		Bumper, 19" Extended, Saber FR/Enforcer	1
72	0640197		Tray, Hose, Center, 19" Bumper, Outside Air Horns Grating, Bumper extension - Grating, Rubber Capacity, Bumper Tray - 20) 125' of 1.75"	1
73	0633479		Hose Restraint, Bumper Tray, Velcro Straps, Pair Qty, Pair - 01	1
74	0614646		No Lift & Tow Package, Imp/Vel, AXT, SFR/Enf	1
75	0002270		Tow Hooks, Chrome	1
76	0632360		Cab, Saber FR, 7010	1
77	0647919		Engine Tunnel, ISL, Saber FR/Enforcer	1
78	0633594		Rear Wall, Interior, Adjustable Seating	1
79	0632103		Rear Wall, Exterior, Cab, Saber FR/Enforcer Material, Exterior Rear Wall - Aluminum Treadplate	1
80	0644201		Cab Lift, Elec/Hyd, Saber FR/Enforcer	1
81	0636939		Grille, Polished Stainless Steel, Front of Cab, Saber	1
82	0002224		Scuffplates, S/S At Cab Door Jambs, 4-Door Cab Material Trim/Scuffplate - c) S/S, Polished	1
83	0647932		Not Required, Trim, S/S Band, Across Cab Face, AXT/Dash CF/Saber/Enforcer	1
84	0087357		Molding, Chrome on Side of Cab	1
85	0521669		Mirrors, Retrac, West Coast Style, Htd/Rmt, w/Htd/Rmt Convex	1



Line	Option	Type	Option Description	Qty
86	0648170		Door, Half-Height, Saber FR/Enforcer 4-Door Cab, Raised Roof Key Model, Cab Doors - 751	1
87	0655543		Door Panel, Brushed Stainless Steel, Saber/Enforcer 4-Door Cab	1
88	0528958		Not Required, Controls, Electric Window, AXT, Quantum, Saber, Enforcer, Dash CF	1
89	0638310		Steps, 4-Door Cab, Saber FR/Enforcer Step Well Material - Aluminum Treadplate	1
90	0634786		Lights, Cab and Crew Cab Access Steps, P25, LED w/Bezel, 1Lt Per Step 6lts	1
91	0002141		Fenders, s/s on cab - Saber/Enforcer	1
92	0637984		Window, Side of C/C, Fixed, Saber FR/Enforcer	1
93	0012090		Not Required, Windows, Front/Side of raised roof	1
94	0779033		Not Required, Windows Rear of Crew Cab, Saber FR/Enforcer	1
95	0797212		Cab Interior, Vinyl Headliner, Saber FR/Enforcer Color, Cab Interior Vinyl/Fabric - a) Silver/Gray Engine Tunnel Cover - Black Imperial 1200 Cab Interior Rear Wall Material - Painted Aluminum	1
96	0012430		Cab Interior, paint color Color, Cab Interior Paint - i) fire smoke gray	1
97	0052100		Floor, Rubber Padded, Cab & Crew Cab, Saber/Enforcer	1
98	0644195		Heater/Defroster, Saber FR/Enforcer	1
99	0644194		Air Conditioning, Saber FR/Enforcer	1
100	0639675		Sun Visor, Smoked Lexan, AXT, Dash CF, Imp/Vel, Saber FR/Enforcer Sun Visor Retention - No Retention	1
101	0634328		Grab Handles, Driver and Officer Door Posts, Saber FR/Enforcer	1
102	0583938		Lights, Engine Compt, Custom, Auto Sw, WIn 3SC0CDCR, 3" LED, Trim Qty, - 01	1
103	0631830		Fluid Check Access, Saber FR/Enforcer, Arrow XT	1
104	0583042		Side Roll and Frontal Impact Protection	1
105	0622617		Seating Capacity, 6 Seats	1
106	0636955		Seat, Driver, Pierce PSV, Air Ride, High Back, Safety, Saber FR/Enforcer	1
107	0636942		Seat, Officer, Pierce PSV, Fixed, SCBA, Safety, Saber FR/Enforcer	1
108	0620420		Radio Compartment, Below Non-Air Ride Seat, Saber FR/Enforcer	1
109	0635973		Seat, Rear Facing C/C, DS Outboard, Pierce PSV, SCBA, Safety, Saber FR/Enforcer	1
110	0102783		Not Required, Seat, Rr Facing C/C, Center	1
111	0635969		Seat, Rear Facing C/C, PS Outboard, Pierce PSV, SCBA, Safety, Saber FR/Enforcer	1
112	0108189		Not Required, Seat, Forward Facing C/C, DS Outboard	1
113	0629498		Cabinet, EMS, Forward Facing, Center, 44 W x 50 H x 18 D, Roll, Saber FR/Enf Door, EMS Cabinet - Amdor Roll Up Dr, No Lock Light, Tall EMS Compt - Pierce, Both Sides	1
114	0108190		Not Required, Seat, Forward Facing C/C, PS Outboard	1
115	0566653		Upholstery, Seats In Cab, Turnout Tuff Color, Cab Interior Vinyl/Fabric - c) Black	1
116	0543991		Bracket, Air Bottle, Hands-Free II, Cab Seats Qty, - 03	3
117	0603866		Seat Belt, Dual Retractor, ReadyReach, Saber FR/Enforcer Seat Belt Color - Red	1
118	0602464		Helmet Storage, Provided by Fire Department, NFPA 2016	1
119	0647647		Lights, Dome, FRP Dual LED 4 Lts Color, Dome Lt - Red & White Color, Dome Lt Bzl - Black Control, Dome Lt White - Door Switches and Lens Switch Control, Dome Lt Color - Lens Switch	1
120	0602637		Portable Hand Light, Provided by Fire Dept, Pumper NFPA 2016 Classification	1
121	0644187		Cab Instruments, Black Gauges, Black Bezels, Saber FR/Enforcer Emergency Switching - Individual Switches	1
122	0002544		Air Restriction Indicator - Pierce Chassis	1
123	0543751		Light, Do Not Move Apparatus Alarm, Do Not Move Truck - Pulsing Alarm	1
124	0637359		Not Required, Door Open Indicator w/Do Not Move Truck Light, Enf/Saber FR	1
125	0644179		Wiper Control, 2-Speed with Intermittent, Saber FR/Enforcer	1
126	0548004		Wiring, Spare, 15 A 12V DC 1st Qty, - 02	2

Line	Option	Type	Option Description	Qty
126			12vdc power from - Battery direct Wire termination - Butt Splice Location, Spare Wiring - Officer Dash	
127	0610240		Vehicle Data Recorder w/Seat Belt Monitor	1
128	0696439		Antenna Mount, Custom Chassis, Cable Routed to Instrument Panel Area Qty, - 01 Location, Antenna Mount - Right Side	1
129	0624249		Electrical Power/Signal Protection & Control, Saber FR	1
130	0624260		Electrical System, Saber FR	1
131	0079166		Batteries, (4) Exide Grp 31, 950 CCA ea, Threaded Stud	1
132	0008621		Battery System, Single Start, All Custom Chassis	1
133	0002698		Battery Compartment, Saber/Enforcer	1
134	0531315		Charger, Sngl Sys, IOTA, DSL-75, 75 Amp, Kussmaul 091-94-12 Ind, Qtm/Enf/SFR	1
135	0012782		Location, Charger, Front Left Side Body Compartment Location, Battery Chrgr/Cmpr - High On Left Wall	1
136	0530949		Location, Battery Charger Indicator, Driver's Seat Riser	1
137	0016857		Shoreline, 20A 120V, Kussmaul Auto Eject, 091-55-20-120, Super Qty, - 01 Color, Kussmaul Cover - b) red Shoreline Connection - Battery Charger	1
138	0026800		Shoreline Location Location, Shoreline(s) - DS Cab Side	1
139	0647729		Alternator, 320 amp, Delco Remy 40SI	1
140	0644176		Load Manager, Integrated In Electrical System, Saber FR/Enforcer	1
141	0783153		Headlights, Rect LED, JW Spkr Evo 2, AXT/DCF/Enf/Imp/Sab/Vel Color, Headlight Bez - Chrome Bezel	1
142	0775055		Light, Directional, Wln C6T* LED Arrow, Common Bzl, Above Headlts,Sab/Enf Color, Lens, LED's - Clear	1
143	0620054		Light, Directional/Marker, Intermediate, Weldon 9186-8580-29 LED 2lts	1
144	0647802		Lights, Clearance/Marker/ID, Front, P25 LED 5 Lts, Saber FR/Enforcer	1
145	0647899		Lights, Directional/Marker, Cab Front Side, Weldon 9186-8580-29 LED, Sab/Enf	1
146	0627282		Lights, Clearance/Marker/ID, Rear, FRP LED Bar & P25 LED 4Lts	1
147	0564683		Lights, Tail, Wln M6BTT* Red LED Stop/Tail & M6T* Amber LED Dir Arw For Hsg Color, Lens - Colored	1
148	0561471		Lights, Backup, Wln M6BUW, LED, For Tail Lt Housing	1
149	0664481		Bracket, License Plate & Light, P25 LED	1
150	0556842		Bezels, Wln, (2) M6 Chrome Pierce, For mtg (4) Wln M6 lights	1
151	0589905		Alarm, Back-up Warning, PRECO 1040	1
152	0666455		Lights, Perimeter Cab, Amdor AY-9500-020 LED 4Dr	1
153	0616847		Lights, Perimeter Pump House, Amdor AY-9500-0** LED 4lts	1
154	0645995		Lights, Perimeter Body, Amdor AY-9500-020 LED 2lts, Rear Step Control, Perimeter Lts - Parking Brake Applied	1
155	0556360		Lights, Step, P25 LED 4lts, Pump Pnl Sw	1
156	0690471		Light, FRC, 12V SPA510-Q20* LED, Pull Up, Top Mount 1st Location - driver side pump house Qty, - 01 To Do Not Move Truck Lt - c) Connected to Lt Switch, Lt Control 1 DC,1 - e) Pump Operators Panel Switch, Lt Control 2 DC,2 - e) No Control Switch, Lt Control 3 DC,3 - d) No Control Switch, Lt Control 4 DC,4 - d) No Control Color, FRC/Rom Lt Housing - FRC, White	1
157	0629192		Light, FRC, 12V SPA260-Q20* LED MAX, Surface Mount 1st Location, Lights - driver side cab above the fixed window Qty, - 01 Switch, Lt Control 1 DC,1 - a) DS Switch Panel Switch, Lt Control 2 DC,2 - e) No Control Switch, Lt Control 3 DC,3 - d) No Control Switch, Lt Control 4 DC,4 - d) No Control Color, FRC/Rom Lt Housing - FRC, Chrome Bezel	1
158	0687209		Light, FRC, 12V SPA510-Q20* LED, Pull Up, Top Mount 2nd Location - passenger side pump house	1

Line	Option	Type	Option Description	Qty
158			Qty, - 01 To Do Not Move Truck Lt - c) Connected to Lt Switch, Lt Control 1 DC,1 - e) Pump Operators Panel Switch, Lt Control 2 DC,2 - e) No Control Switch, Lt Control 3 DC,3 - d) No Control Switch, Lt Control 4 DC,4 - d) No Control Color, FRC/Rom Lt Housing - FRC, White	
159	0629191		Light, FRC, 12V SPA260-Q20* LED MAX, Surface Mount 2nd Location, Lights - passenger side cab above the crew cab window Qty, - 01 Switch, Lt Control 1 DC,1 - a) DS Switch Panel Switch, Lt Control 2 DC,2 - g) PS Switch Panel Switch, Lt Control 3 DC,3 - d) No Control Switch, Lt Control 4 DC,4 - d) No Control Color, FRC/Rom Lt Housing - FRC, Chrome Bezel	1
160	0618301		Light, Visor, FRC, 12V SPA851-Q15-*, LED 1st Qty, - 01 Location, driver's/passenger's/center - centered Switch, Lt Control 1 DC,1 - DS & PS Switch Panel Switch, Lt Control 2 DC,2 - e) No Control Switch, Lt Control 3 DC,3 - d) No Control Color, FRC/Rom Lt Housing - FRC, White Chrome Face	1
161	0532358		Not Required, Deck Lights, Other Hose Bed & Rear Lighting	1
162	0645869		Lights, Hose Bed, Sides, WIn 01-066D068-00 Blk Trim LED, 1.87" Lights 4lts Control, Hose Bed Lts - Cup Switch At Rear	1
163	0645612		Lights, Rear Scene, FRC, SPA900-Q70, 42" - 90" High Control, Rear Scene Lts - Cab Switch Panel DS and Body Switch, DS Rear Bulkhead Control, Rear Scene Lts - Cab Switch Panel DS and Body Switch, DS Rear Bulkhead	1
164	0709438		Light, Walking Surface, FRP Flood, LED	1
165	0693709		Pumper, Medium, Aluminum, 2nd Gen, Saber/Commercial	1
166	0632361		No Additional Florida Discount - w/Saber FR Chassis	1
167	0554271		Body Skirt Height, 20"	1
168	0028245		Tank, Water, 750 Gallon, Poly, Med	1
169	0003405		Overflow, 4.00" Water Tank, Poly	1
170	0028104		Foam Cell Required	1
171	0633066		Sleeve through Tank Qty, Sleeve - 1 Water Tank Sleeve - Plumbing/Hydraulic Diameter - 3" Plumbing	1
172	0553729		Not Required, Restraint, Water Tank, Heavy Duty	1
173	0003429		Not Required, Direct Tank Fill	1
174	0003424		Not Required, Dump Valve	1
175	0048710		Not Required, Jet Assist	1
176	0030007		Not Required, Dump Valve Chute	1
177	0514778		Not Required, Switch, Tank Dump Master	1
178	0689065		Hose Bed, Aluminum, Saber/Commercial	1
179	0627877		Hose Bed Capacity, 1000' of 5.00", 1000' of 3.00"	1
180	0083488		Divider, Hose Bed, .25" Unpainted Qty, Hosebed Dividers - 2	2
181	0589278		Hose Restraint, Hose Bed, Velcro Strap on Top, 2" Heavy Nylon Web at Rear Type of fastener - seat belt buckle Nylon Web Color - Black Type of fastener, Rear - seat belt buckle - bottom of hosebed	1
182	0010133		Cross-Divider, Hose Bed	1
183	0013512		Running Boards, 12.75" Deep	1
184	0689621		Tailboard, 16" Deep	1
185	0690037		Wall, Rear, Smooth Aluminum/Body Material Material, Rear Wall Inboard Facing Surfaces - Aluminum Diamondplate	1
186	0003531		Tow Bar, Under Tailboard	1
187	0003561		Construction, Compt, Alum, Pumper	1
188	0083686		LS 152" Rollup, Full Height & Depth Front & Rear	1
189	0063658		RS 152" Rollup, Full Height Front & Rear, FDLER	1

Line	Option	Type	Option Description	Qty
190	0692733		Doors, Rollup, Gortite, Side Compartments Qty, Door Accessory - 06 Color, Roll-up Door, Gortite - Painted to Match Lower Body Latch, Roll-up Door, Gortite - Non-Locking Liftbar	6
191	0083701		Rear, Rollup, 44.50" FF	1
192	0692746		Door, Gortite, Rollup, Rear Compartment Color, Roll-up Door, Gortite - Satin finish Latch, Roll-up Door, Gortite - Non-Locking Liftbar	1
193	0554995		No Body Modification Required	1
194	0625184		Guard, Drip Pan, S/S, Rollup Door, Pumper Qty, Door Accessory - 07 Location, Door Guard/Drip Pan - D3, D2, D1, R1, P3, P2 and P1	7
195	0616670		Lights, Compt, Pierce LED, Dual Light Strips, Each Side of Door, Pumper/Tanker Qty, - 07 Location, Compartment Lights - All Body Compts	7
196	0687146		Shelf Tracks, Painted Qty, Shelf Track - 07 Location, Shelf Track - D3, D2, D1, R1, P1, P2 and P3	7
197	0600350		Shelves, Adj, 500 lb Capacity, Full Width/Depth, Predefined Locations Qty, Shelf - 08 Material Finish, Shelf - Painted - Spatter Gray Location, Shelves/Trays, Predefined - .Location To Be Determined	8
198	0647091		Tray, Floor Mounted, Slide-Out, 500lb, 2.00" Sides Qty, - 03 Location, Tray Slide-Out, Floor Mounted - D1, P1 and R1 Material Finish, Tray - Painted - Spatter Gray	3
199	0024016		Rub Rail, Aluminum Extruded, Side & Rear of Body	1
200	0784811		Fender Crowns, Rear, Stainless, w/Removable Liner Material Finish, Fender Liner - Painted	1
201	0519849		Not Required, Hose, Hard Suction	1
202	0625546		Handrails, Top Mount Pump Panel, Per Print	1
203	0004126		Handrails, Beavertail, Standard	1
204	0004146		Handrail, Rear, Below Hose Bed, Full Width	1
205	0636301		Compt, Extinguisher (2) in Fender Panel, Triangular Door Location, Bracket/comp. - passenger side behind the rear wheels Qty, - 1 Door Finish, Fender Compt - Polished Latch, Air Bottle Compt - Flush Lift & Turn Insert, Air Bottle Compt - Rubber Matting	1
206	0622393		Compt, Air Pack in Fender Panel Location, Bracket/comp. - driver side front of rear wheels Qty, - 01 Door Finish, Fender Compt - Polished Latch, Air Bottle Compt - Flush Lift & Turn Insert, Air Bottle Compt - Rubber Matting	1
207	0657522		Compt, Air Bottle, Triple, Fender Panel Qty, Air Bottle Comp - 1 Door Finish, Fender Compt - Polished Location, Fender Compt - Triple - PS Fwd Latch, Air Bottle Compt - Flush Lift & Turn Insert, Air Bottle Compt - Rubber Matting	1
208	0654143		Compt, Air Bottle, Single, Common Triple Door (DEF/Fuel), Fender Panel Door Finish, Fender Compt - Polished Latch, Air Bottle Compt - Flush Lift & Turn Insert, Air Bottle Compt - Rubber Matting	1
209	0004225		Ladder, 24' Duo-Safety 900A 2-Section	1
210	0004230		Ladder, 14' Duo-Safety 775A Roof	1
211	0049958		Ladders Btwn Tank & S.Sht, PS, Ext'd Rr, Encl'd Complete, RPH Door, Material & Finish, Ladder Storage - c) smooth aluminum Latch, Door Ladder Storage - D-Handle latch	1
212	0014245		Ladder, 10' Duo-Safety Folding 585A, w/Mounting Location, Folding Ladder - Ladder Compartment	1

Line	Option	Type	Option Description	Qty
213	0602877		Pike Pole, Pumper, Provided by Fire Department, NFPA 2016 Pike Pole Make/Model - Duo-Safety 10' Pike Pole	1
214	0602875		Pike Pole, 6', Pumper, Provided by Fire Department, NFPA 2016 Pike Pole Make/Model - Duo-Safety 6' Pike Pole	1
215	0004361		Tubes, Alum, Pike Pole Storage Qty, Pike Pole Tubes - 02 Location, Pike Pole Tube - Ladder Storage	2
216	0024388		No Steps Required, Front Of Body	1
217	0592994		Steps, Folding, Rear of Body, w/LED, Trident Coating, Step - black	1
218	0004425		Pump, Waterous, CSU, 1500 GPM, Single Stage	1
219	0004482		Seal, Mechanical, Waterous	1
220	0559769		Trans, Pump, Waterous C20 Series	1
221	0635600		Pumping Mode, Stationary Only	1
222	0605126		Pump Shift, Air w/Manual Override, Split Shaft, Interlocked, Waterous	1
223	0003148		Transmission Lock-up, EVS	1
224	0004547		Auxiliary Cooling System	1
225	0014486		Not Required, Transfer Valve, Stage Pump	1
226	0777622		Valve, Relief Intake, Elkhart, w/Pressure Features Pressure Setting - 125 psig	1
227	0536322		Controller, Pressure, Pierce, Custom Chassis	1
228	0072153		Primer, Trident, Air Prime, Air Operated	1
229	0780364		Manuals, Pump, (2) Total, Electronic Copies	1
230	0602512		Plumbing, Stainless Steel and Hose, Single Stage Pump, Control Zone	1
231	0795135		Plumbing, Stainless Steel, w/Foam System	1
232	0004645		Inlets, 6.00" - 1250 GPM or Larger Pump	1
233	0004646		Cap, Main Pump Inlet, Long Handle, NST, VLH	1
234	0084610		Valves, Akron 8000 series- All	1
235	0004660		Inlet, Left Side, 2.50"	1
236	0029147		Not Required, Inlet, Right Side	1
237	0004687		Valve, Inlet(s) Recess, Top Mount	1
238	0004710		Control, Inlet, at Top Mount Panel Qty, Inlets - 1	1
239	0092569		No Rear Inlet (Large Dia) Requested	1
240	0092696		Not Required, Cap, Rear Inlet	1
241	0064116		No Rear Inlet Actuation Required	1
242	0009648		No Rear Intake Relief Valve Required on Rear Inlet	1
243	0092568		No Rear Auxiliary Inlet Requested	1
244	0563738		Valve, .75" Bleeder, Aux. Side Inlet, Swing Handle	1
245	0029043		Tank to Pump, (1) 3.00" Valve, 3.00" Plumbing	1
246	0004905		Outlet, Tank Fill, 1.50"	1
247	0004940		Outlet, Left Side, 2.50" Qty, Discharges - 02	2
248	0092570		Not Required, Outlets, Left Side Additional	1
249	0004945		Outlet, Right Side, 2.50" Qty, Discharges - 01	1
250	0092571		Not Required, Outlets, Right Side Additional	1
251	0005047		Outlet, 4.00" w/4.00" Right, Handwheel Valve, Brand - Akron	1
252	0649939		Outlet, Front, 1.50" w/2.00" Plumbing Fitting, Outlet - 1.50" NST with 90 degree swivel Drain, Front Outlet - Automatic Location, Front, Single - in center bumper tray	1
253	0004995		Outlet, Rear, 2.50" Qty, Discharges - 01 Location, Outlet - b) driver's side	1
254	0092574		Not Required, Outlet, Rear, Additional	1
255	0092573		Not Required, Outlet, Hose Bed/Running Board Tray	1
256	0085076		Caps for 1.50" to 3.00" Discharge, VLH	1
257	0563739		Valve, 0.75" Bleeder, Discharges, Swing Handle	1
258	0005091		Elbow, Left Side Outlets, 45 Degree, 2.50" FNST x 2.50" MNST, VLH	1

Line	Option	Type	Option Description	Qty
259	0035094		Not Required, Elbow, Left Side Outlets, Additional	1
260	0025091		Elbow, Right Side Outlets, 45 Degree, 2.50" FNST x 2.50" MNST, VLH	1
261	0089584		Not Required, Elbow, Right Side Outlets, Additional	1
262	0045091		Elbow, Rear Outlets, 45 Degree, 2.50" FNST x 2.50" MNST, VLH	1
263	0085695		Not Required, Elbow, Rear Outlets, Large, Additional	1
264	0005097		Elbow, Large Dia Outlet, 30 Deg, 4.00" FNST x 5.00" Storz Qty, - 01	1
265	0062133		Control, Outlets, Manual, Pierce HW if applicable	1
266	0090927		Outlet, 3.00" Deluge w/TFT Extend-a-Gun XG18	1
267	0029302		No Monitor Requested	1
268	0029304		No Nozzle Req'd	1
269	0005070		Deluge Mount, NPT	1
270	0025140		Not Required, 1.50" Crosslays	1
271	0090442		Crosslays Sngl Sheet Unpainted, (1) 2.50" Std Cap	1
272	0064896		Speed, (2) 1.50" W/ Poly Tray, Top Mt/Side Cntrl, Std. Cap.	1
273	0500535		Not Required, Hose Restraint, Crosslay/Speedlay	1
274	0019853		Crosslays, 8.00" Lower Than Standard - Control Zone w/9.00" Raised PH	1
275	0624939		Foam Sys, Husky 3, Single Agent, Multi Select Feature Discharge, Foam Locations - Front Bumper Center, Rear Outlet Left Side, Crosslay Front and Crosslay Rear Discharge, Foam Locations - Front Bumper Center, Rear Outlet Left Side, Crosslay Front and Crosslay Rear	1
276	0012126		Not Required, CAF Compressor	1
277	0592527		Refill, Foam Tank, Integral, Husky 3	1
278	0031896		Demonstration, Foam System, Dealer Provided	1
279	0559077		Foam Cell, 30 Gallon, Not Reduce Water Type of Foam - Class "A" Foam, Brand Name - TBD	1
280	0697589		Drain, 1.00", Foam Tank #1, Husky 3 Foam System	1
281	0091079		Not Required, Foam Tank #2	1
282	0091112		Not Required, Foam Tank #2 Drain	1
283	0018666		Pump House, Top Mount, 52", w/19" Walkway, Control Zone Light, Walkway Compt - P25 LED Light, Walkway - P25 LED, 6lts Location, Walkway Lights - Back Of Custom Cab	1
284	0032479		Pump Panel Configuration, Control Zone	1
285	0635253		Material, Pump Panels, Top Control Painted FormCoat Black, Side Panels Painted Material Finish, Pump Panel, Side Control - Painted FormCoat Black Material, Pump Panel, Side Control - Aluminum Material, Pump Panel, Top Control - Aluminum Material Finish, Pump Panel, Top Control - Painted FormCoat Black	1
286	0035574		Panel, Pump Access - Both Sides	1
287	0037731		Pump House Structure, Raised, Included with Ladder Storage	1
288	0583824		Light, Pump Compt, Wln 3SC0CDCR LED White Qty, - 01	1
289	0586382		Gauges, Engine, Included With Pressure Controller	1
290	0005601		Throttle Included w/ Pressure Controller	1
291	0549333		Indicators, Engine, Included with Pressure Controller	1
292	0511078		Gauges, 4.00" Master, Class 1, 30"-0-600psi	1
293	0511100		Gauge, 2.00" Pressure, Class 1, 30"-0-400psi	1
294	0536428		Gauge, Water Level, Pierce, In pressure Controller	1
295	0604028		Water Level Gauge, FRC, MaxVision WLA280-A00 Programable Remote Display Location - each side of cab behind the crew cab doors as high as possible Qty, - 02 Activation, Water Level G - pb) parking brake is applied	2
296	0604354		Gauge, Foam Level, FRC, Tank Vision Pro, WLA 360-A00, Class "A"	1
297	0648885		Light Shield, Top Mt, LED Strip Lights	1
298	0606695		Air Horns, (2) Grover, Stutter Tone, 24" Long, in Bumper	1
299	0606835		Location, Air Horns, Bumper, Each Side, Outside Frame, Outboard (Pos #1 & #7)	1
300	0016065		Control, Air Horn, Horn Ring, PS Chrome Push Button	1
301	0525667		Siren, Wln 295SLSA1, 100 or 200 Watt	1

Line	Option	Type	Option Description	Qty
302	0790527		Location, Electronic Siren, Center Dash Switch Panel, Saber FR Location, Electronic Siren - switch panel # 7	1
303	0076156		Control, Elec Siren, Head Only	1
304	0601306		Speaker, (1) Wln, SA315P, w/Pierce Polished Stainless Steel Grille, 100 watt Connection, Speaker - siren head	1
305	0601565		Location, Speaker, Frt Bumper, Recessed, Center (Pos 4)	1
306	0016080		Siren, Federal Q2B	1
307	0006095		Siren, Mechanical, Mounted Above Deckplate Location, Siren, Mech - a) Left	1
308	0026163		Control, Mech Siren, DS & PS Foot Sw	1
309	0606721		Lightbar, Wln, Freedom IV-V, 60", R_RR__RR__RR_R Filter, Whl Freedom Ltbrs - No Filters	1
310	0016380		No Additional Lights Req'd, Side Zone Upper	1
311	0540384		Lights, Front Zone, Wln M6°C LED, Clear Lens, in Common Bzl Color, Lt DS Front - Red Color, Lt PS Front - Red	1
312	0653937		Flasher, Headlight Alternating Headlt flash deactivation - a)w/high beam	1
313	0540692		Lights, Side Zone Lower, Wln M6°C LED, Clear Lens, 3pr, Ovr 25 Location, Lights Front Side - b)each side bumper Color, Lt Side Front - Red Color, Lt Side Middle - Red Color, Lt Side Rear - Red Location, Lights Mid Side - Rearward of Crew Cab Doors Location, Lights Rear Side - Over Rear Wheels	1
314	0564655		Lights, Rear Zone Lower, Wln M6°C LED, Clear Lens, For Tail Lt Housing Color, Lt DS Rear - r) DS Rear Lt Red Color, Lt PS Rear - r) PS Rear Lt Red	1
315	0088745		Light, Rear Zone Upper, Wln L31HRFN LED Beacon, Red LED Color, Dome, Rear Warning - j) both domes clear	1
316	0006551		Not Required, Lights, Rear Upper Zone Blocking	1
317	0006615		Mtg, Rear Warn Lts, On Top of Compt	1
318	0006646		Electrical System, 120/240VAC, General Design	1
319	0563275		Generator, Harrison 6kW MSV, Hydraulic, Hotshift PTO, Volt Meter Only Generator Interlocks - Parking Brake	1
320	0006645		Location, Hydraulic Generator Above Pump Location, Generator(s) - Over Pump, Left Side	1
321	0016752		Starting Sw, Truck Engine Powered Gen, Cab Sw Pnl	1
322	0651902		Remote Start, Hydraulic Generator, 1 Location Location 1 - pump panel	1
323	0016740		Not Required, Fuel System	1
324	0016767		Not Required, Oil Drain Extension, Generator	1
325	0016771		Not Required, Routing Exhaust, Generator	1
326	0036738		Circuit Breaker Panel, Included With PTO Generator Location, Circuit Breaker Panel - D3, Back Wall High	1
327	0526992		Reel, Elect Cable, Akron, (3) Wire Qty, Cord Reels - 1 Reel Guide - b) Captive roller Finish, Reel - Powder Coated Silver Location, Electric Cord Reel - R1, High & Right, 1 Reel	1
328	0788933		Box, Junc, Akron, 3Wire, 2-15/20A 120V Dup SB, 2-20A 120V TL Qty, - 01 Connection, Electric Plug / Inlet (Male) - Direct Connection	1
329	0519934		Not Required, Brand, Hydraulic Tool System	1
330	0649753		Not Required, PTO Driven Hydraulic Tool System	1
331	0649750		Not Required, Hydraulic Reels	1
332	0007150		Bag of Nuts and Bolts Qty, Bag Nuts and Bolts - 1	1
333	0602516		NFPA Required Loose Equipment, Pumper, NFPA 2016, Provided by Fire Department	1
334	0067022		Hose, 6.00" Soft Suction - 15 Ft. Long	1
335	0027023		No Strainer Required	1

Line	Option	Type	Option Description	Qty
336	0602538		Extinguisher, Dry Chemical, Pumper NFPA 2016 Class, Provided by Fire Department	1
337	0602360		Extinguisher, 2.5 Gal. Pressurized Water, Pumper NFPA 2016, Provided by Fire Dept	1
338	0602679		Axe, Flathead, Pumper NFPA 2016 Classification, Provided by Fire Department	1
339	0602667		Axe, Pickhead, Pumper NFPA 2016 Classification, Provided by Fire Department	1
340	0607712		Paint Process / Environmental Requirements	1
341	0568511		Paint, Two Tone w/Shield, 90 Red & White, Saber PMFD	1
			Paint Color-Upper-PMFD - #10 white	
			Paint Color, Saber, PMFD - #90 Red	
342	0646901		Paint Chassis Frame Assy, With Liner, E-Coat, Standard	1
			Paint Color, Frame Assembly, Predefined - Black	
343	0693797		No Paint Required, Aluminum Front Wheels	1
344	0693792		No Paint Required, Aluminum Rear Wheels	1
345	0007230		Compartment, Painted, Spatter Gray	1
346	0544129		Reflective Band, 1"-6"-1"	1
			Color, Reflect Band - A - a) white	
			Color, Reflect Band - B - l) white	
			Color, Reflect Band - C - w) white	
347	0007356		Reflective across Cab Face	1
348	0536954		Stripe, Chevron, Rear, Diamond Grade, Pumper	1
			Color, Rear Chevron DG - fluorescent yellow green	
349	0087342		Jog, "Z"-Shaped, In Reflective Stripe	1
			Qty, - 1	
350	0552453		Stripe, Reflective, Chevron, Cab and Crew Cab Doors Interior, Diamond Grade	1
			Color, Reflect Band - A - o) fluorescent yellow diamond grade	
			Size, Chevron Striping - 06	
			Color, Reflect Chev - A - r) red diamond grade	
351	0027372		Lettering Specifications, (GOLD STAR Process)	1
352	0685687		Lettering, Printed Effect Gold Leaf, 3.00", (81-100)	1
			Outline, Lettering - Outline and Shade	
353	0519961		Lettering, Website Address, Reflective, Pair	1
			Location, Lettering - TBD	
			Qty, - 01	
354	0686084		Lettering, Reflective, 3.00", Each	5
			Qty, Lettering - 05	
			Outline, Lettering - Outline and Shade	
355	0516701		Emblem, American Flag Painted on Cab Grille, All Custom Chassis	1
356	0077162		Emblem, "Star of Life", 10", Reflective, Pair	1
357	0537144		Emblem, Reflective, Per Dept. Patch, Each, PMFD	1
			Qty, - 1	
			Location, Emblem - rear door	
358	0529225		Manuals, Two (2) CD, Fire Apparatus Parts, Custom Chassis	1
359	0531636		Manual, Two (2) CD, Chassis Service, Custom	1
360	0531638		Manual, Two (2) CD, Chassis Operation, Custom	1
361	0030008		Warranty, Basic, 1 Year, Apparatus, WA0008	1
362	0595239		(No Pick Required)	1
363	0696698		Warranty, Engine, Cummins, 5 Year, WA0181	1
364	0684952		Warranty, Steering Gear, TRW Ross TAS, 1 Year WA0202	1
365	0596017		Warranty, Frame, 50 Year, Custom Chassis, WA0013	1
366	0610471		Warranty, Axle, Eaton/Dana, 5 Year/100,000 Mile, Parts and Labor	1
367	0610485		Warranty, Axle, Eaton/Dana, 5 Year/100,000 Mile, Parts and Labor	1
368	0652758		Warranty, ABS Brake System, 3 Year, Meritor Wabco, WA0232	1
369	0019914		Warranty, Structure, 10 Year, Custom Cab, WA0012	1
370	0595813		Warranty, Paint, 10 Year, Cab, Pro-Rate, WA0055	1
371	0647720		Warranty, Pierce LED Strip Lights, WA0203	1
372	0046369		Warranty, 5-year EVS Transmission, Standard Custom, WA0187	1
373	0685945		Warranty, Transmission Cooler, WA0216	1
374	0688798		Warranty, Water Tank, Lifetime, UPF, Poly Tank, WA0195	1
375	0596025		Warranty, Structure, 10 Year, Body, WA0009	1
376	0693127		Warranty, Gortite, Roll-up Door, 6 Year, WA0190	1
377	0063510		Warranty, Pump, Waterous, 5 Year Parts, WA0225	1
378	0648675		Warranty, 10 Year S/S Pumbing, WA0035	1



Line	Option	Type	Option Description	Qty
379	0657990		Warranty, Foam System, Husky 3, WA0231	1
380	0609981		Warranty, Harrison Generator, 6 Year, WA0285	1
381	0595820		Warranty, Paint, 10 Year, Body, Pro-Rate, WA0057	1
382	0595421		Warranty, Goldstar, 3 Year, Apparatus, WA0018	1
383	0683627		Certification, Vehicle Stability, CD0156	1
384	0777618		Certification, Engine Installation, Saber FR/Enf, Cummins L9, 2017 CD0158	1
385	0686786		Certification, Power Steering, CD0098	1
386	0631980		Certification, Cab Integrity, Saber FR/Enforcer, CD0130	1
387	0631973		Certification, Cab Door Durability, Saber FR/Enforcer, CD0137	1
388	0631978		Certification, Windshield Wiper Durability, Saber FR/Enforcer, CD0132	1
389	0556828		Certification, Electric Window, Not Available	1
390	0631977		Certification, Seat Belt Anchors and Mounting, Saber FR/Enforcer, CD0134	1
391	0631976		Certification, Cab Heater and Defroster, Saber FR/Enforcer, CD0131	1
392	0631971		Certification, Cab Air Conditioning Performance, Saber FR/Enforcer, CD0135	1
393	0545073		Amp Draw Report, NFPA Current Edition	1
394	0002758		Amp Draw, NFPA/ULC Radio Allowance	1
395	0799248		Appleton/Florida BTO	1
396	0000017		FLORIDA DIVISION BODY	1
397	0000012		PIERCE CHASSIS	1
398	0004713		ENGINE, OTHER	1
399	0046395		EVS 3000 Series TRANSMISSION	1
400	0020011		WATEROUS PUMP	1
401	0020009		POLY TANK	1
402	0028048		FOAM SYSTEM	1
403	0020005		TOP MOUNT	1
404	0020007		AKRON VALVES	1
405	0020015		ABS SYSTEM	1
406	0658751		Manufacturing Attribute	1



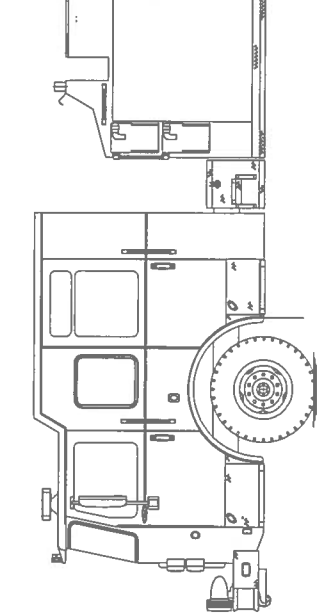
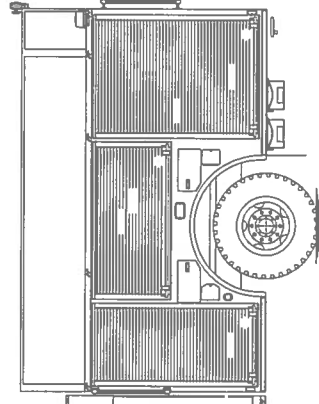
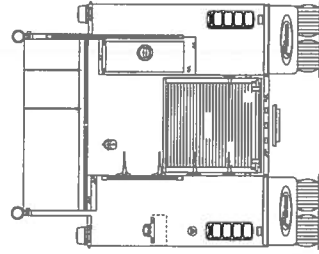
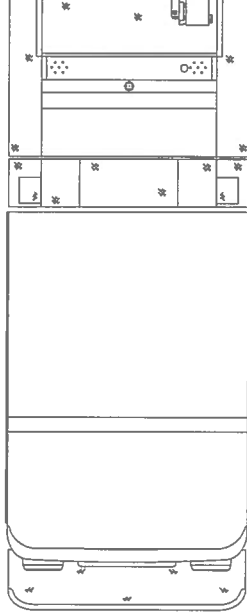
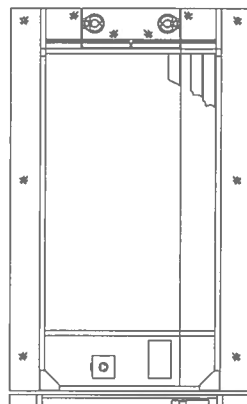
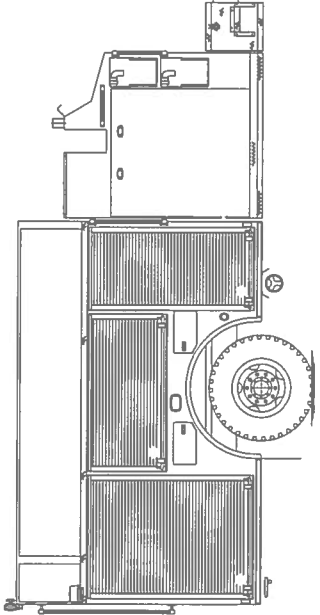
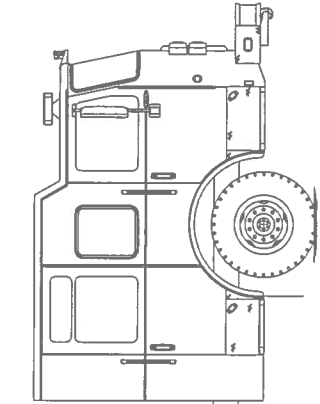
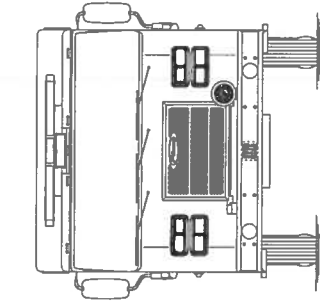

NOTE:  
LAYOUT AND SIZES PROVIDED BY CUSTOMERS  
MAY VARY DUE TO AVAILABLE WORKING SPACE.

COLOR LEGEND	
PINK	LETTERING (VINYL OR REFLECTIVE)
ORANGE	STRIPING (VINYL OR REFLECTIVE)
GREEN	GOLD LEAF
YELLOW	CUSTOMER FURNISHED PRODUCT

<b>CUSTOMER APPROVAL</b>		<b>Pierce MANUFACTURING INC.</b>		JOB NO.	—
APPROVED BY: _____		TITLE: LETTERING, STRIPING, AND PAINTING INSTRUCTIONS		SCALE	1:24
DATE: _____		FOR: PCB 5808R-FR		DRAWN BY	—
CHASSIS DATA	PIERCE	DATE	NO.	ORDER BY	—
REV. DATE	BY	OR	NO.	DATE	—
REV. DATE	BY	OR	NO.	DATE	—
LSP-LP				SET NO.	D
				1 OF 1	

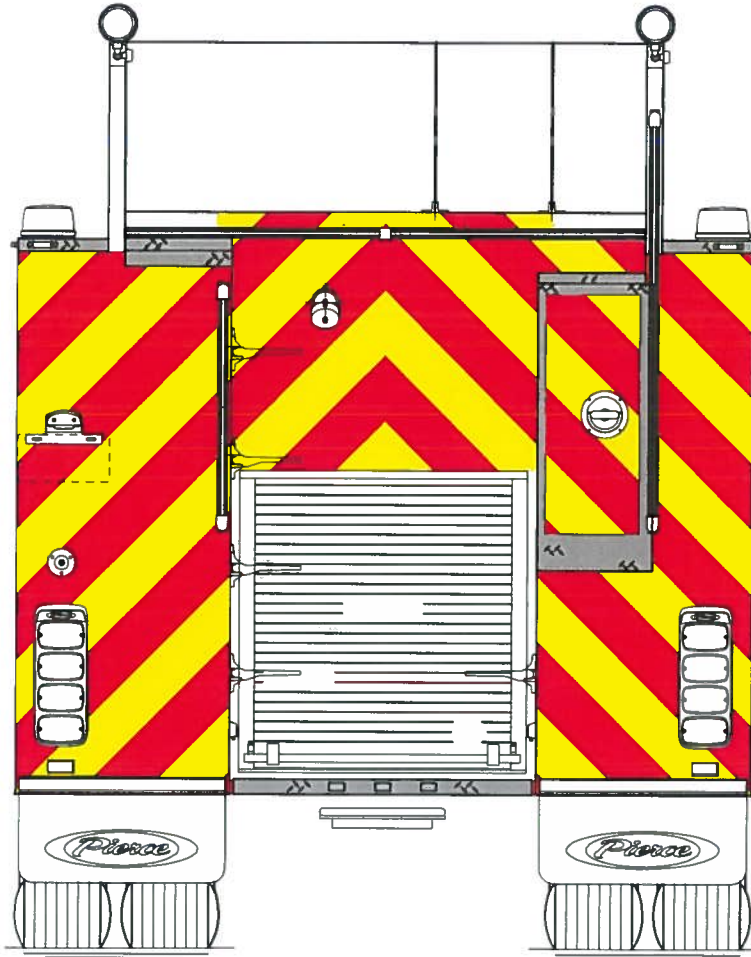

**CUSTOMER APPROVAL**

APPROVED BY: \_\_\_\_\_  
 DATE: \_\_\_\_\_

NOTE: PLEASE REVIEW CHEVRON COVERAGE AND DOOR MATERIAL PER PULSE OPTIONS. NON-RELATED OR NON-CRITICAL MINOR DEVIATIONS MAY EXIST.



**MANUFACTURING INC.**

JOB NO.

-

SCALE

1:24

DRAWN BY

-

DATE

04JAN18

TITLE

CHEVRON DRAWING

-

FOR

PCB Saber FR

-

DWG NO.

CHEVRON-CD

SHEET SIZE

A

SHEET NO.

1 OF 1

# Lease Rate Estimator

Enter values to estimate lease payments using the current rates available through Pierce financial services. Additional financing details and options can be found on the Pierce website (see link below).

Lease    Notes

## Parameters

Equipment Cost (USD)

535845

Down Payment (USD)

0.00

Lease Term (Years)

7

Payment Estimate Good Through

1/31/2018

Annual Lease Payment

\$86,331.09

End Of Term Option

\$1.00

Documentation Fees

\$0.00

Estimate

First payment 1 year after lease commencement.

Annual lease payment assumes lessee will not issue more than \$10 million in tax-exempt debt this year.

Call 1-800-820-9041

Pierce Financing Website (<http://www.piercemfg.com/pierce/pierce-financial-solutions>)

The SalesNet resource, and all related estimator tools, may be used to obtain product estimates based on the specific values you have entered and/or the options that you have selected. The SalesNet estimates are subject to a number of variables and may change based upon any future modification to a product variable, specification or configuration option. Certain product measurements and specifications are subject to a standard variance as determined by the manufacturer from time to time. Any estimates provided to Pierce Manufacturing Inc. customers and/or any other third party shall be clearly and expressly qualified by the above-referenced limitations.

© 2018 Pierce Manufacturing Inc.

