

PANAMA CITY BEACH CITY COUNCIL AGENDA

NOTE: AT EACH OF ITS REGULAR OR SPECIAL MEETINGS, THE CITY COUNCIL ALSO SITS, EX-OFFICIO, AS THE CITY OF PANAMA CITY BEACH COMMUNITY REDEVELOPMENT AGENCY AND MAY CONSIDER ITEMS AND TAKE ACTION IN THAT LATTER CAPACITY.

MEETING DATE: JULY 23, 2020
MEETING TIME: 9:00 A.M.

A. CALL TO ORDER

1. ROLL CALL.
2. INVOCATION – PASTOR RAMON DUVALL, BEACHSIDE FELLOWSHIP CHURCH.
3. PLEDGE OF ALLEGIANCE – COUNCILMAN CHESTER.
4. COMMUNITY ANNOUNCEMENTS.
5. APPROVAL OF MINUTES OF REGULAR MEETINGS OF JUNE 11 AND JUNE 25, AND STRATEGIC PLANNING WORKSHOP OF JUNE 18, 2020.
6. APPROVAL OF AGENDA, AND ADDITIONS OR DELETIONS.
7. PRESENTATIONS.
 - A. “NATIONAL KOREAN WAR VETERANS ARMISTICE DAY” PROCLAMATION, PRESENTATION TO COMMANDER MARY LEMBURG, VFW POST 10555.
 - B. EMPLOYEE RECOGNITION.
 - C. LEGISLATIVE RECOGNITION: SENATOR GEORGE GAINER, REPRESENTATIVE JAY TRUMBULL, FLORIDIAN PARTNERS, LLC.
8. PUBLIC COMMENTS –NON-AGENDA BUSINESS (LIMITED TO THREE MINUTES).

B. REGULAR AGENDA – DISCUSSION/ACTION

1. KJ NORTH GLADES COMMERCIAL PLAT APPROVAL, PUBLIC HEARING, (CONTINUED)
2. ML ORDINANCE 1518, AMENDING MAXIMUM HEIGHT IN MILITARY OVERLAY DISTRICT, 2ND READING, PUBLIC HEARING.
3. ML ORDINANCE 1535, CODE ENFORCEMENT AUTHORITY, 1ST READING.
4. TO ORDINANCE 1534, BEACH SAFETY EMERGENCY LANES, 1ST READING.
5. TO RESOLUTION 20-138, CITY CLERK CONTRACT.
6. DW RESOLUTION 20-139, PD VEHICLE PURCHASE.
7. DW DISCUSSION, REQUEST FOR PROPOSAL FOR POLICE BODY WORN CAMERAS.
8. AS RESOLUTION 20-140, CROSS CONNECTION PROGRAM UPDATE.

- 9. TO RESOLUTION 20-141, ECONOMIC DEVELOPMENT ADVISORY COMMITTEE CREATION.
 - 10. TO APPOINTMENT OF COUNCIL LIAISON AND ECONOMIC DEVELOPMENT ADVISORY COMMITTEE.
 - 11. TO COVID-19 ACTION AND DISCUSSION.
 - 12. TO DISCUSSION, ADMINISTRATIVE REORGANIZATION.
 - 13. TO DISCUSSION, FRANK BROWN PARK 8 ACRE DEVELOPMENT.
 - 14.* DC DISCUSSION, SOUTH THOMAS PARKING LOT DEVELOPMENT.
 - 15. TO DISCUSSION, FOOD TRUCKS IN CITY LOT.
- C. CITY MANAGER REPORT.
 - D. CITY ATTORNEY REPORT.
 - E. COUNCIL COMMENTS.
 - F. ADJOURN.

*Action items noted with an asterisk are taken both by the City Council and the Panama City Beach Redevelopment Agency jointly and concurrently.

PAUL CASTO X
 PHIL CHESTER X
 GEOFF MCCONNELL X
 MICHAEL JARMAN X
 MARK SHELDON X

I certify that the Council members listed above have been contacted and given the opportunity to include items on this agenda.

 7/17/20
 Interim City Clerk Date

PAUL CASTO X
 PHIL CHESTER X
 GEOFF MCCONNELL X
 MICHAEL JARMAN X
 MARK SHELDON X

I certify that the Council members listed above have been contacted and made aware of the items on this agenda.

 7/17/20
 Interim City Clerk Date

IN ACCORDANCE WITH EXECUTIVE ORDER 20-139 COUNCIL CHAMBERS WILL BE OPEN FOR PHYSICAL ATTENDANCE BUT LIMITED TO 50 PERSONS.

E-mailed to interested parties and posted on the website on: 07/20/20 12:00 P.M.

NOTE: COPIES OF THE AGENDA ITEMS ARE POSTED ON THE CITY'S WEBSITE WWW.PCBGOV.COM THIS MEETING WILL BE LIVE-STREAMED ON THE CITY

WEBSITE AND CITY FACEBOOK PAGE “CITY OF PANAMA CITY BEACH-GOVERNMENT”.

NOTE: ONE OF MORE MEMBERS OF OTHER CITY BOARDS MAY APPEAR AND SPEAK AT THIS MEETING.

If a person decides to appeal any decision made by the City Council with respect to any matter considered at the meeting, if an appeal is available, such person will need a record of the proceeding, and such person may need to ensure that a verbatim record of the proceeding is made, which record includes the testimony and evidence upon which the appeal is based. Sec. 286.0105, FS (1995).

COMMUNITY ANNOUNCEMENTS

COMMUNITY ANNOUNCEMENTS 7/23/20

7/30	Bid Opening- City Parks Chemical Applications	Council Chambers
7/30	Bid Opening- City Parks Mowing & Landscape Maintenance	Council Chambers
7/30-8/2	Soccer Youth All American Series	PCB Sports Complex
8/7-8/9	Travel Ball USA	Frank Brown Park
8/10-8/16	5 Tool Baseball Playcations	PCB Sports Complex
8/11	Bid Opening- Janitorial Services	Council Chambers
8/12	Planning Board meeting	Council Chambers
8/13	Upcoming Council meeting	Council Chambers
8/15	Region D Qualifying League FYSA & Bay United	PCB Sports Complex

Copies of this announcement on the table

DRAFT MINUTES

The Regular Meeting of the City Council of the City of Panama City Beach, Florida, and when permitted or required by the subject matter, the Panama City Beach Community Redevelopment Agency, held on June 11, 2020.

ROLL

MAYOR MARK SHELDON

COUNCILORS:

PAUL CASTO

PHIL CHESTER

GEOFF MCCONNELL

MICHAEL JARMAN

CITY MANAGER:

TONY O'ROURKE

INTERIM CITY CLERK:

JO SMITH

CITY ATTORNEY:

AMY MYERS

Mayor Sheldon called the meeting to order at 6:00 P.M.

Councilman McConnell gave the invocation and led the Pledge of Allegiance.

Mayor Sheldon read the Community Announcements.

The Minutes of the Regular Meeting of April 23, 2020 were presented for approval.

Councilman Chester made the motion to approve the Minutes as written. Second was by Councilman Casto and the motion passed by unanimous roll call vote recorded as follows:

Councilman McConnell	Aye
Councilman Jarman	Aye
Councilman Casto	Aye
Councilman Chester	Aye
Mayor Sheldon	Aye

Mayor Sheldon asked if there were any additions or deletions to the Agenda. Mr. O'Rourke asked to add a presentation by Mr. Matt Bush, Classic Rentals, about LSVs. He also asked to swap positions with Regular Items 5 and 6. There were no objections.

Councilman McConnell made the motion to approve the amended Agenda. Second was by Councilman Chester and the motion passed by unanimous roll call vote recorded as follows:

Councilman McConnell	Aye
Councilman Jarman	Aye
Councilman Casto	Aye
Councilman Chester	Aye
Mayor Sheldon	Aye

PRESENTATIONS

1 Mr. Andrew Rowell, Bay County Chamber of Commerce. Mr. Rowell presented Mayor Sheldon with the "Apple of the Eye" award for the new City Hall. Mayor Sheldon thanked the Chamber and also Mr. Shortt for his work on this building.

2 Mr. Matt Bush, Classic Rentals. Mr. Bush said he and the other owners had put a plan together for the industry and Beach Police to enact. He spoke of the problems with overnight rentals, and stated that the LSV industry would enact age restrictions and disabling the Bluetooth speakers which helped alleviate some of the problems. He said he had the same plan for this upcoming weekend. He spoke of having a meeting with the other owners, Chief Whitman, the City Manager and the Mayor to discuss options and create a plan.

Mayor Sheldon applauded the industry for their thinking. He said the City would meet with the industry and be open to ideas. He said stopping the bluetooth was a good idea.

Councilman Casto spoke of the rentals traveling on the Parkway. Mr. Bush described the decal and map which noted where they could go and where not.

Ms. Colleen Swab, CA Cycles, said they made their own rules for the LSVs, requiring being 25 or older to rent on the weekends. She also would obtain a copy of their insurance card and drivers license. She urged the community to call her office if they saw any of her vehicles doing anything illegal as she would then get them off the road. She agreed in taking the keys away if there was reckless driving. She asked the Council not to pass any new Ordinances as they would set up a plan.

PUBLIC COMMENTS - NON-AGENDA BUSINESS (LIMITED TO THREE MINUTES)

Mayor Sheldon opened the Public Comments section at 6:16 P.M. and asked for comments.

1 Mr. Burnie Thompson. Mr. Thompson said it was refreshing for the Council to be service-oriented and the Mayor doing the right thing by recusing himself from the vote.

2 Ms. Sherry Trumball. Ms. Trumball spoke of a petition for speed humps on San Souci. Ms. Jenkins replied that speed humps were normally handled during resurfacing.

3 Mr. Gary Beck. Mr. Beck spoke of the powerful media and corruption. He spoke of his struggle for the last ten years.

4 Mr. Robert Hardy. Mr. Hardy asked about wheelchair access to the beach. Councilman Casto responded that the City Pier had beach wheelchairs and Mayor Sheldon said the County Pier did also.

5 Mr. Shane. Mr. Shane spoke of the beach chaos and flag signs not replaced after the hurricane. He urged the Beach Police to enforce the existing laws.

6 Mr. Fred Broussard. Mr. Broussard spoke online giving kudos to Mr. Bush and Ms. Swab for trying to find a solution. He spoke of the flag system but people getting in the water regardless. He urged the City to find a solution to keep people out of the water.

With no further comments, the Mayor closed the Public Comment section at 6:35 P.M.

CONSENT AGENDA

ITEM 1 RESOLUTION 20-119, BID AWARD- UNDERGROUND UTILITIES PIPE AND FITTINGS. *"A Resolution of the City of Panama City Beach, Florida, authorizing the purchase of pipe and fittings from Empire Pipe and Supply Company, Inc., Fortiline, Inc., and Lanier Municipal Supply Co., Inc., in the total amount of \$115,263.64, as more specifically set forth in the body of the Resolution."*

ITEM 2 REVISION OF THE MASTER AUDIT LIST TO REMOVE OBSOLETE ITEMS. *These items are to be removed from the Master Audit List. STAFF RECOMMENDS approval. By approval of this matter in the Consent Agenda, the City*

Council makes a finding of surplus for these items and approves their removal from the Master Audit List.

ITEM 3 RESOLUTION 20-120, SUPPORTING FUNDING REQUEST FOR PCB PARKWAY REUSE TRANSMISSION EXTENSION PROJECT. "A Resolution of the City of Panama City Beach, Florida, indicating its support of the City's pursuit of State of Florida alternative water supply funding for the City of Panama City Beach Parkway Reuse Transmission Extension project; ratifying a letter of support; and authorizing the appropriate officers of the City to provide any other documents necessary to satisfy the requirements of the application for funding."

ITEM 4 APPROVAL OF UPDATED JOB DESCRIPTIONS. With the implementation of the City's new online job application system, Staff updated the City's job descriptions to provide consistency, accuracy, and to ensure each was suitable for the new system and to prepare for the upcoming pay plan study. Staff recommends approval.

ITEM 5 RESOLUTION 20-121, NUISANCE ABATEMENT SEACLUSION CIRCLE. "A Resolution of the City of Panama City Beach, Florida, approving an amount of \$854.90 to be liened on property located at Lot 106, Lot 107, and Lot 108 Seaclusion Circle, for costs incurred by the City to abate nuisances located upon such property; authorizing the appropriate officers of the City to record the lien and notify interested parties of such lien; and providing an immediately effective date."

ITEM 6 RESOLUTION 20-126, APPLYING FOR NAUTILUS GOLF CART CROSSING. "A Resolution of the City of Panama City Beach, Florida, directing the appropriate officers of the City to prepare and submit an application to FDOT for the establishment of a golf cart crossing at the intersection of Panama City Beach Parkway and Nautilus Street; and providing an immediately effective date."

ITEM 7 RESOLUTION 20-117, JEEP JAM BEACH TURTLE KRAWL ROAD CLOSURE. "A Resolution of the City of Panama City Beach authorizing rerouting a portion of traffic on a portion of Front Beach Road on Friday, June 19, 2020, for the "Florida Jeep Jam Beach Turtle Krawl"; and providing an immediately effective date."

ITEM 8 RESOLUTION 20-125, LOCAL ACCESS MANAGEMENT PLAN DEVELOPMENT. "A Resolution of the City of Panama City Beach, Florida, approving an Agreement with Florida Transportation Engineers for the development of an Access Management Plan in the basic amount of \$22,500."

Ms. Smith read the Consent Agenda by titles.

Councilman McConnell made the motion to approve the Consent Agenda. Second was by Councilman Jarman and the motion passed by unanimous roll call vote recorded as follows:

Councilman McConnell	Aye
Councilman Jarman	Aye
Councilman Casto	Aye
Councilman Chester	Aye
Mayor Sheldon	Aye

AMENDED REGULAR AGENDA- DISCUSSION/ACTION

ITEM 1 RESOLUTION 20-122, COVID-19 RELATED MEASURES. Prior to Ms. Myers reading the Resolution by title, Mayor Sheldon announced that he would recuse himself from voting since his business required a special event permit at time and that he promoted those events. Ms. Myers read Resolution 20-122 by title. Mayor Sheldon called for comments from the audience or online, and there were none. Ms. Ward received no emails.

Mr. O'Rourke outlined the latest plan, such as increasing the number for summer camp and increasing the groups at the Lyndell Center. He said Staff looked at opening the open swim at the Aquatic Center and Kiddie Pool, opening the facilities to the public and consideration of the delinquent water accounts.

Councilman McConnell asked about the Youth Sports, and Mr. Ponek replied that the programs would start in July, with fall soccer, fall baseball and some adult baseball.

Councilman Casto asked about the Summer Concert Series. He said it would be mostly local families. Mr. Ponek said he hoped to start July 9th or July 16th. Mr. O'Rourke reminded that the Governor had restrictions for groups fifty or less. He said the Concert Series could not comply with those restriction. Mr. O'Rourke said he would bring something back to Council for the June 25th meeting. Councilman Chester said maybe July 23rd might be a good date.

Councilman Chester made the motion to approve Resolution 20-122. Second was by Councilman Casto and the motion passed by unanimous roll call vote of those members voting recorded as follows:

Councilman McConnell	Aye
Councilman Jarman	Aye
Councilman Casto	Aye
Councilman Chester	Aye
Mayor Sheldon	Recused

A copy of Mayor Sheldon's Memorandum of Voting Conflict is attached to and becomes an official part of these Minutes.

ITEM 2 ORDINANCE 1524, FIREFIGHTERS' PENSION PLAN AMENDMENT RELATED TO CANCER, 1ST READING. Ms. Myers read Ordinance 1524 by title. Mayor Sheldon asked if there were any audience or online comments, and there were none. Ms. Ward had no emails. Mr. O'Rourke said this Ordinance followed the new State Statute.

Councilman Casto made the motion to approve Ordinance 1524. Second was by Councilman Jarman and the motion passed by unanimous roll call vote recorded as follows:

Councilman McConnell	Aye
Councilman Jarman	Aye
Councilman Casto	Aye
Councilman Chester	Aye
Mayor Sheldon	Aye

ITEM 3 RESOLUTION 20-123, RESIDENTIAL PARKING PILOT PROGRAM. Ms. Myers read Resolution 20-123 by title. Mayor Sheldon asked if there were any audience or online comments, and there were none. Ms. Ward had no emails. Mayor Sheldon clarified that the cap for the daily fee was six dollars (\$6.00) and that this would be a great benefit to the City residents.

Councilman Jarman made the motion to approve Resolution 20-123. Second was by Councilman Chester and the motion passed by unanimous roll call vote recorded as follows:

Councilman McConnell	Aye
Councilman Jarman	Aye
Councilman Casto	Aye
Councilman Chester	Aye
Mayor Sheldon	Aye

ITEM 4 ORDINANCE 1527, RESIDENTIAL PARKING DECAL PROGRAM, 1ST READING. Ms. Myers read Ordinance 1527 by title. Mayor Sheldon asked if there were any audience or online comments, and there were none. Ms. Ward had no emails. Mayor Sheldon asked if the stickers were transferrable if the vehicle was sold or wrecked. Mr. O'Rourke responded that the owner would come to the Public Services building for a new sticker.

Councilman McConnell made the motion to approve Ordinance 1527. Second was by Councilman Casto and the motion passed by unanimous roll call vote recorded as follows:

Councilman McConnell	Aye
Councilman Jarman	Aye
Councilman Casto	Aye
Councilman Chester	Aye
Mayor Sheldon	Aye

ITEM 5 RESOLUTION 20-111, BID AWARD- APPROVING WRECKER SERVICE CONTRACTS. Ms. Myers read Resolution 20-111 by title. Mayor Sheldon asked if there were any audience or online comments, and there were none. Ms. Ward had no emails. Chief Whitman said the sole source wrecker service was working well and he had no issues with the current service. He spoke of their ability to clean up traffic and they helped with the impound yard at no charge to the City. He added that their employees were licensed to do traffic control at the scenes to release the patrol officers to respond to other calls.

Councilman Casto asked about performance. Chief Whitman responded that the current service could respond within five to ten minutes and had 115 wreckers in this area. He stated he was happy with this company. Councilman Jarman said the issue should be revisited at the end of the contract. Mayor Sheldon said if there were no problems, no need to change.

Councilman Jarman made the motion to reject the new contract. Second was by Councilman Chester and the motion passed by unanimous roll call vote recorded as follows:

Councilman McConnell	Aye
Councilman Jarman	Aye
Councilman Casto	Aye
Councilman Chester	Aye
Mayor Sheldon	Aye

ITEM 6 ORDINANCE 1528, MODIFICATION OF TOWING RATES, 1ST READING. Mayor Sheldon explained the Ordinance would be rejected since a new contract was not being considered.

Councilman Jarman made the motion to reject Ordinance 1528. Second was by Councilman Chester and the motion passed by unanimous roll call vote recorded as follows:

Councilman McConnell	Aye
Councilman Jarman	Aye
Councilman Casto	Aye
Councilman Chester	Aye
Mayor Sheldon	Aye

ITEM 7 RESOLUTION 20-124, FRANK BROWN PARK CONCESSION LEASE MODIFICATION. Ms. Myers read Resolution 20-124 by title. Mayor Sheldon asked if there were any audience or online comments, and there were none. Ms. Ward had no emails. Mayor Sheldon asked about the issues with the credit card machines not working at the concession stand. Mr. Poniek said that was being addressed by adding more internet at the Park. Mayor Sheldon asked Mr. O'Rourke to look into the issue.

Councilman Jarman asked if sales were tracked. Mr. Poniek said the vendor had a good history and he explained the contract features.

Councilman McConnell made the motion to approve Resolution 20-124. Second was by Councilman Chester and the motion passed by unanimous roll call vote recorded as follows:

Councilman McConnell	Aye
Councilman Jarman	Aye
Councilman Casto	Aye
Councilman Chester	Aye
Mayor Sheldon	Aye

ITEM 8 FINANCIAL MANAGEMENT ADVISORY COMMITTEE COUNCIL LIAISON APPOINTMENT. Mayor Sheldon asked if there were any audience or online comments, and there were none. Ms. Ward had no emails.

Councilman Jarman made the motion to appoint Councilman McConnell to the Committee as he was active in this area. Second was by Councilman Casto and the motion passed by unanimous roll call vote recorded as follows:

Councilman McConnell	Aye
Councilman Jarman	Aye
Councilman Casto	Aye
Councilman Chester	Aye
Mayor Sheldon	Aye

ITEM 9* RESOLUTION 20-127, CONDEMNATION OF PROPERTY LOCATED AT 17138 AND 17140 FRONT BEACH ROAD. Ms. Myers read Resolution 20-127 by title. Mayor Sheldon asked if there were any audience or online comments, and there were none. Ms. Ward had no emails. Mayor Sheldon said the City had offered fair market value. Ms. Myers said this was for business purposes and was at the request of the business owners.

Councilman Chester made the motion to approve Resolution 20-127. Second was by Councilman Jarman and the motion passed by unanimous roll call vote recorded as follows:

Councilman McConnell	Aye
Councilman Jarman	Aye
Councilman Casto	Aye
Councilman Chester	Aye
Mayor Sheldon	Aye

ITEM 10 SEPTIC TO SEWER CONNECTION, DISCUSSION. Mr. Shortt presented a Powerpoint presentation, with the history of the City's utility system. He spoke of the Grand Lagoon area, where sewer was installed due to a grant. He said cost was the driving factor with conversion being incredibly expensive. He explained the gravity sewer, the low-pressure sewer and vacuum collection sewer systems. He reviewed the history of neighborhood conversions, with the costs financed over five years and utility customers outside of the City limits were charged an extra 25%. Mr. Shortt explained the Bayside project where the City coordinated that conversion with the County replacing the road.

Mayor Sheldon suggested surveying the neighborhoods to see where most would connect. Councilman Casto said the five-year financing was a good incentive. The Mayor said many residents had asked for it, and Councilman McConnell said he was concerned that some people did not have the money to convert. Councilman Jarman said Staff could look into grant programs. Discussion ensued and Mr. Shortt said he would bring figures back for the next Council meeting.

ITEM 11 EMPLOYEE SURVEY RESULTS, DISCUSSION. Mayor Sheldon called for comments from the audience and online, and there were none. Ms. Ward received no emails. Mr. O'Rourke explained the Employee input with 96% participation, and it was the City's duty now to act. He spoke of the City's efforts to work on communication and the flow of information from Department Heads to Staff. He spoke of the action plan and enhancing leadership, optimizing performance.

Councilman McConnell thanked the Employees in that a 96% response rate was unheard of. He said it was more typically 50%. He said their input was important to the Council. Mayor Sheldon said the employees were hungry for a change.

ITEM 12 FIRE DEPARTMENT SCHEDULE SHIFT 48/96, DISCUSSION. Mayor Sheldon called for audience comments and online comments, and there were none. Ms. Ward received no emails.

Mr. O'Rourke said this was a popular shift and a great recruitment tool. He said this change would also help with retention and a cost savings. The Fire Department had a 93% approval from the Firefighters. The tentative date was set for October 1st.

Chief Couch said this was a huge step and only a few Departments used this schedule in NW Florida. He said this new approach would offer reduced sick time with his officers, being mentally healthier and overall healthier. He said Lt. Tim Smith had put a lot of effort into this project.

CITY MANAGER REPORT

Mr. O'Rourke spoke of the use of force and how the Police Department administered force when necessary. He explained matching the response to the resistance. He spoke of self-regulation so that the community would not lose faith.

Regarding Beach safety, Mr. O'Rourke said the City had experienced five drownings in three weeks. He spoke of proactive education concerning rip currents and urged adherence to the beach flag system. He spoke of taking personal responsibility

and more education on double red flag situations. He spoke of our current lifeguard situation and the distances between stands. He added that the City could not carry that burden alone, and that the private sector could match the City's coverage. He said the City needed to use more than flags in this digital age. Mr. O'Rourke suggested working with the hotels and the TDC.

A Strategic Planning Workshop was planned for June 18th with one hundred people participating. He said the Council would vote on the final version, with a mission and core values. Once the Council adopted the final version, a draft would be developed for Council consideration in August.

Mr. O'Rourke said the Financial Management Advisory Committee would meet Monday at 3 P.M. The CRA Advisory Committee would be discussed on the June 25th Council meeting, and then the Economic Development, and finally the Public Safety Committee.

CITY ATTORNEY REPORT

Ms. Myers said the Governor was releasing the CARES Act which would help the City reimbursements.

COUNCIL COMMENTS

Councilman Casto thanked the Police and Fire Departments for the beach water safety employees. He said the City would issue a Request for Proposal to see how many of the private sector wanted to participate.

Councilman Chester echoed Councilman Casto's comments and thanked Lt. Smith for his work on changing the Fire shifts.

Councilman McConnell thanked the Police Department and Chief Whitman for their critical support, and his pride of the Chief's leadership of his staff and Dispatch. He also urged the residents to complete the Census as it would help the City with funding.

Councilman Jarman spoke of the false alarms and the request for a discussion on the June 25th meeting.

Mayor Sheldon discussed the status of the COVID-19 public health crisis in Panama City Beach. He spoke of efforts to clean the beach and questioned the trash can costs for Gayle's Trails. He requested to revisit the rule about three rods on the Pier and asked for a report back. He asked if there were future plans for more basketball courts. Related to beach bonfires, the Mayor asked to look at vendors and how to make the process more efficient. He spoke of the turtle watch and how to expand the program, not hinder it. Mayor Sheldon mentioned a new program that would allow someone to receive a text when the flags changed.

With nothing further, the meeting was adjourned at 8:30 P.M.

**** ACTION ITEMS NOTED WITH AN ASTERISK ARE TAKEN BOTH BY THE CITY COUNCIL AND THE PANAMA CITY BEACH REDEVELOPMENT AGENCY JOINTLY AND CONCURRENTLY.**

READ AND APPROVED this 23rd of July, 2020.

IN THE EVENT OF A CONFLICT BETWEEN THE FOREGOING MINUTES AND A VERBATIM TRANSCRIPT OF THESE MINUTES, THE FOREGOING MINUTES SHALL CONTROL.

Mayor

ATTEST:

Interim City Clerk

DRAFT

FORM 8B MEMORANDUM OF VOTING CONFLICT FOR COUNTY, MUNICIPAL, AND OTHER LOCAL PUBLIC OFFICERS

LAST NAME—FIRST NAME—MIDDLE NAME SHELDON MARK	NAME OF BOARD, COUNCIL, COMMISSION, AUTHORITY, OR COMMITTEE CITY OF PANAMA CITY BEACH CITY COUNCIL
MAILING ADDRESS 17007 PANAMA CITY BEACH PARKWAY	THE BOARD, COUNCIL, COMMISSION, AUTHORITY OR COMMITTEE ON WHICH I SERVE IS A UNIT OF: <input checked="" type="checkbox"/> CITY <input type="checkbox"/> COUNTY <input type="checkbox"/> OTHER LOCAL AGENCY
CITY PANAMA CITY BEACH	COUNTY BAY
DATE ON WHICH VOTE OCCURRED JUNE 11, 2020	NAME OF POLITICAL SUBDIVISION: CITY OF PANAMA CITY BEACH
	MY POSITION IS: <input checked="" type="checkbox"/> ELECTIVE <input type="checkbox"/> APPOINTIVE

WHO MUST FILE FORM 8B

This form is for use by any person serving at the county, city, or other local level of government on an appointed or elected board, council, commission, authority, or committee. It applies to members of advisory and non-advisory bodies who are presented with a voting conflict of interest under Section 112.3143, Florida Statutes.

Your responsibilities under the law when faced with voting on a measure in which you have a conflict of interest will vary greatly depending on whether you hold an elective or appointive position. For this reason, please pay close attention to the instructions on this form before completing and filing the form.

INSTRUCTIONS FOR COMPLIANCE WITH SECTION 112.3143, FLORIDA STATUTES

A person holding elective or appointive county, municipal, or other local public office **MUST ABSTAIN** from voting on a measure which would inure to his or her special private gain or loss. Each elected or appointed local officer also **MUST ABSTAIN** from knowingly voting on a measure which would inure to the special gain or loss of a principal (other than a government agency) by whom he or she is retained (including the parent, subsidiary, or sibling organization of a principal by which he or she is retained); to the special private gain or loss of a relative; or to the special private gain or loss of a business associate. Commissioners of community redevelopment agencies (CRAs) under Sec. 163.356 or 163.357, F.S., and officers of independent special tax districts elected on a one-acre, one-vote basis are not prohibited from voting in that capacity.

For purposes of this law, a "relative" includes only the officer's father, mother, son, daughter, husband, wife, brother, sister, father-in-law, mother-in-law, son-in-law, and daughter-in-law. A "business associate" means any person or entity engaged in or carrying on a business enterprise with the officer as a partner, joint venturer, coowner of property, or corporate shareholder (where the shares of the corporation are not listed on any national or regional stock exchange).

* * * * *

ELECTED OFFICERS:

In addition to abstaining from voting in the situations described above, you must disclose the conflict:

PRIOR TO THE VOTE BEING TAKEN by publicly stating to the assembly the nature of your interest in the measure on which you are abstaining from voting; *and*

WITHIN 15 DAYS AFTER THE VOTE OCCURS by completing and filing this form with the person responsible for recording the minutes of the meeting, who should incorporate the form in the minutes.

* * * * *

APPOINTED OFFICERS:

Although you must abstain from voting in the situations described above, you are not prohibited by Section 112.3143 from otherwise participating in these matters. However, you must disclose the nature of the conflict before making any attempt to influence the decision, whether orally or in writing and whether made by you or at your direction.

IF YOU INTEND TO MAKE ANY ATTEMPT TO INFLUENCE THE DECISION PRIOR TO THE MEETING AT WHICH THE VOTE WILL BE TAKEN:

- You must complete and file this form (before making any attempt to influence the decision) with the person responsible for recording the minutes of the meeting, who will incorporate the form in the minutes. (Continued on page 2)

APPOINTED OFFICERS (continued)

- A copy of the form must be provided immediately to the other members of the agency.
- The form must be read publicly at the next meeting after the form is filed.

IF YOU MAKE NO ATTEMPT TO INFLUENCE THE DECISION EXCEPT BY DISCUSSION AT THE MEETING:

- You must disclose orally the nature of your conflict in the measure before participating.
- You must complete the form and file it within 15 days after the vote occurs with the person responsible for recording the minutes of the meeting, who must incorporate the form in the minutes. A copy of the form must be provided immediately to the other members of the agency, and the form must be read publicly at the next meeting after the form is filed.

DISCLOSURE OF LOCAL OFFICER'S INTEREST

I, MARK SHELDON, hereby disclose that on JUNE 11, 20 20 :

(a) A measure came or will come before my agency which (check one or more)

- inured to my special private gain or loss;
- inured to the special gain or loss of my business associate, _____ ;
- inured to the special gain or loss of my relative, _____ ;
- inured to the special gain or loss of _____, by whom I am retained; or
- inured to the special gain or loss of _____, which is the parent subsidiary, or sibling organization or subsidiary of a principal which has retained me.

(b) The measure before my agency and the nature of my conflicting interest in the measure is as follows:

RESOLUTION 20-122 OF THE CITY OF PANAMA CUTY BEACH WHICH ALLOWED THE PERMITTING OF SPECIAL EVENTS DURING THE COVID-19 PUBLIC HEALTH CRISIS. AS THE MANAGING MEMBER OF PCB ENTERTAINMENT, LLC AND R&M ENTERTAINMENT, LLC, I HOST SPECIAL EVENTS IN THE CITY OF PANAMA CITY BEACH. THE COUNCIL'S ACTION ON THAT DAY WOULD ENABLE MY EVENTS TO TAKE PLACE UNDER REGULATIONS SET FORTH BY THE COUNCIL AND THUS WOULD INURE TO BY SPECIAL PRIVATE GAIN OR LOSS.

If disclosure of specific information would violate confidentiality or privilege pursuant to law or rules governing attorneys, a public officer, who is also an attorney, may comply with the disclosure requirements of this section by disclosing the nature of the interest in such a way as to provide the public with notice of the conflict.

JUNE 12, 2020

Date Filed

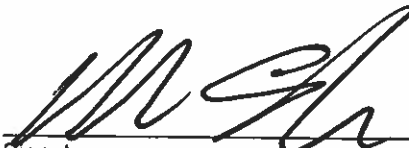
Signature

NOTICE: UNDER PROVISIONS OF FLORIDA STATUTES §112.317, A FAILURE TO MAKE ANY REQUIRED DISCLOSURE CONSTITUTES GROUNDS FOR AND MAY BE PUNISHED BY ONE OR MORE OF THE FOLLOWING: IMPEACHMENT, REMOVAL OR SUSPENSION FROM OFFICE OR EMPLOYMENT, DEMOTION, REDUCTION IN SALARY, REPRIMAND, OR A CIVIL PENALTY NOT TO EXCEED \$10,000.

The Strategic Planning Workshop of the City Council of the City of Panama City Beach, Florida, held on June 18, 2020.

ROLL

MAYOR MARK SHELDON

COUNCILORS:

PAUL CASTO

PHIL CHESTER

GEOFF MCCONNELL

MICHAEL JARMAN

CITY MANAGER:

TONY O'ROURKE

INTERIM CITY CLERK:

JO SMITH

CITY ATTORNEY:

AMY MYERS

Mayor Sheldon called the meeting to order at 9:00 A.M.

Councilman Jarman gave the invocation and led the Pledge of Allegiance.

Mayor Sheldon welcomed the members of the community. He also asked if there were any public comments and there were none.

Mr. O'Rourke explained the multi-step process to create the Strategic Plan, a living document. He said the Council would ultimately decide the core elements and values with the assistance of the community and staff.

The Council then broke into five groups with community members and staff.

The first part of the meeting concerned **SWOT** (Strengths, Weaknesses, Opportunities, and Threats). The different groups offered numerous ideas and the Council members chose one idea from each category. Beginning with **Strengths**, the Council chose Airport, beach, tourism, no sales or property tax, and public service. For **Weaknesses**, the ideas chosen were no hospital, lack of affordable housing, lack of lifeguards, traffic and road infrastructure. For **Opportunity**, the ideas chosen were CRA, Convention Center, Bay Parkway future development, citizen communications, and indoor sports facility. For **Threats**, the ideas chosen were lack of technology, lack of education on the beach flag system, City vs FDOT on roadways, over-regulation by the State, and 100-milers.

The next task was creating a **Vision** of what the City would be in the next 25 to 30 years. Five great ideas were offered by the groups and the Council elected to merge all five ideas into one vision statement. **A safe, family-friendly, vibrant community that values residents, businesses and visitors; supports cultural and economic diversity; and maintains outstanding quality of life.**

The groups next discussed creating the **Mission Statement** for the City. Five sets of great statements were offered, and the Council elected to merge all five into one Mission Statement for the City. **Provide responsible leadership that facilitates and supports the community vision to develop a high-quality environment.**

Core Values were discussed by each group, and six ideas were offered by each. The Council members ultimately chose Visionary, Safety, Integrity/Honesty, Fiscally Responsible, Aesthetics/Beautification, and Transparency/Open Communication.

The groups next discussed **Priorities**, and each group offered six ideas for consideration. The Council members ultimately chose Public Safety, hospital, attractive community, financial health, transportation, and economic development.

Mr. O'Rourke said a draft plan would be created, tested with the focus groups, and then brought to the Council for adoption. He said the plan would also be revisited every six months to keep the City on course. Once the draft plan was ready, a copy would be emailed to the focus groups for comments.

With nothing further, the meeting was adjourned at 11:30 A.M.

READ AND APPROVED this 23rd of July, 2020.

IN THE EVENT OF A CONFLICT BETWEEN THE FOREGOING MINUTES AND A VERBATIM TRANSCRIPT OF THESE MINUTES, THE FOREGOING MINUTES SHALL CONTROL.

Mayor

ATTEST:

Interim City Clerk

The Regular Meeting of the City Council of the City of Panama City Beach, Florida, and when permitted or required by the subject matter, the Panama City Beach Community Redevelopment Agency, held on June 25, 2020.

ROLL

MAYOR MARK SHELDON

COUNCILORS:

PAUL CASTO

PHIL CHESTER

GEOFF MCCONNELL

MICHAEL JARMAN

CITY MANAGER: `

TONY O'ROURKE

INTERIM CITY CLERK:

JO SMITH

CITY ATTORNEY:

AMY MYERS

Mayor Sheldon called the meeting to order at 9:00 A.M.

Councilman Jarman gave the invocation and led the Pledge of Allegiance.

Mayor Sheldon read the Community Announcements.

The Minutes of the Regular Meeting of May 14, 2020 were presented for approval.

Councilman Chester made the motion to approve the Minutes as written.

Second was by Councilman Casto and the motion passed by unanimous roll call vote recorded as follows:

Councilman Jarman	Aye
Councilman Casto	Aye
Councilman Chester	Aye
Councilman McConnell	Aye
Mayor Sheldon	Aye

Mayor Sheldon asked if there were any additions or deletions to the Agenda. There were none.

Councilman Chester made the motion to approve the Agenda as prepared.

Second was by Councilman Casto and the motion passed by unanimous roll call vote recorded as follows:

Councilman Jarman	Aye
Councilman Casto	Aye
Councilman Chester	Aye
Councilman McConnell	Aye
Mayor Sheldon	Aye

PRESENTATIONS

Councilman Casto presented 30-year plaques to longtime employees James Creamer, David Jordan, and Bo Reeves. Councilman Chester presented the fifteen-year plaque to Greg Andrews, and Ms. Philput read the names Buster Pate and Cpl. Joey Pettys from their plaques as they could not attend the meeting. Councilman McConnell presented the ten-year plaques to Allison Marshall, Robert Williams, and Bill Woodcock.

Ms. Philput said Michael Sparks could not attend but who would receive his ten-year plaque. Councilman Jarman presented the five-year plaques to Gary Godsey, Jeremiah Jagers, Anthony Malko, Robert Moss, and Jonah Pokipala. Ms. Philput said Steve Holley could not attend but who would receive his five-year plaque. Mayor Sheldon presented retirement plaques to Police Officers Cpl. Michele McDonald and Lt. Danny McDonald, honoring their 19 and 24 years of service respectively.

PUBLIC COMMENTS - NON-AGENDA BUSINESS (LIMITED TO THREE MINUTES)

Mayor Sheldon opened the Public Comments section at 9:15 A.M. and asked for comments.

1 Ms. Carrie Philimonte. Ms. Philimonte read a prepared statement asking for mandatory masks in the City. She spoke of hospitalizations and said it was not fair for the high risk people to have to stay home.

2 Ms. Missy Sparks. Ms. Sparks invited the City Council to the Grand Opening at Candlewood Suites.

3 Ms. Genese Hatcher. Ms. Hatcher said masks available in the grocery stores would stop the spread of the virus.

4 Mr. Gary Beck. Mr. Beck spoke of the government destroying the tools he needed to make a living. He spoke of the media spreading lies.

With no further comments, the Mayor closed the Public Comments section at 9:30 A.M.

REGULAR AGENDA- DISCUSSION/ACTION

ITEM 1 RESOLUTION 20-129, COVID-19 RELATED MEASURES. Ms. Myers read Resolution 20-129 by title. Mr. O'Rourke spoke of the cases doubling within the last five days compared to the last three months. He said given the facts today, he recommended the involuntary water utility disconnections and late payment delinquency actions resume although staff would be sensitive. He said the issue would be revisited in two weeks and let data drive the decision making.

Councilman Jarman asked about the Summer Concert Series. Councilman McConnell suggested a delay and Councilman Casto concurred. Mr. O'Rourke said staff was looking at the evidence but not going full ahead. Councilman Chester suggested starting the Summer Concert Series at the end of July. Councilman McConnell said all the ICU beds were not filled with COVID patients. Mayor Sheldon said the hospitals were doing elective surgeries and Gulf Coast Hospital was bringing back more of their employees. The Mayor recommended moving forward with the early payouts.

Ms. Myers read the revised Resolution 20-129 with the Council changes.

Councilman McConnell made the motion to approve the revised Resolution 20-129. Second was by Councilman Jarman and the motion passed by unanimous roll call vote recorded as follows:

Councilman Jarman	Aye
Councilman Casto	Aye
Councilman Chester	Aye
Councilman McConnell	Aye
Mayor Sheldon	Aye

ITEM 2 ORDINANCE 1523, GENERAL EMPLOYEE PENSION CHARTER OFFICER VESTING, 2ND READING, PUBLIC HEARING. Ms. Myers read Ordinance 1523 by title. Mayor Sheldon opened the Public Hearing at 9:41 A.M. and asked for

comments from the audience; there were none. He closed the Public Hearing at 9:41 A.M.

Councilman McConnell made the motion to approve Ordinance 1523. Second was by Councilman Jarman and the motion passed by unanimous roll call vote recorded as follows:

Councilman Jarman	Aye
Councilman Casto	Aye
Councilman Chester	Aye
Councilman McConnell	Aye
Mayor Sheldon	Aye

ITEM 3 ORDINANCE 1526, CITY ADVISORY BOARD GOVERNANCE, 2ND READING, PUBLIC HEARING. Ms. Myers read Ordinance 1526 by title. Mayor Sheldon opened the Public Hearing at 9:43 A.M. and called for comments; there were none. The Mayor closed the Public Hearing at 9:43 A.M. Mr. O'Rourke said the Financial Management Advisory Committee meetings started last month which would provide assistance to Staff and the Council.

Councilman Jarman made the motion to approve Ordinance 1526. Second was by Councilman McConnell and the motion passed by unanimous roll call vote recorded as follows:

Councilman Jarman	Aye
Councilman Casto	Aye
Councilman Chester	Aye
Councilman McConnell	Aye
Mayor Sheldon	Aye

ITEM 4* RESOLUTION 20-130, CRA ADVISORY COMMITTEE CREATION. Ms. Myers read Resolution 20-130 by title. Mayor Sheldon called for comments and there were none. Councilman Chester said he preferred five Committee members, not ten. Councilman Casto and Councilman Jarman concurred. Councilman McConnell said he thought the Economic Development Committee could use ten members. Mayor Sheldon said he had been prepared to appoint two Committee members.

Councilman Chester made the motion to approve Resolution 20-130 with five members. Second was by Councilman Casto and the motion passed by unanimous roll call vote recorded as follows:

Councilman Jarman	Aye
Councilman Casto	Aye
Councilman Chester	Aye
Councilman McConnell	Aye
Mayor Sheldon	Aye

ITEM 5* APPOINTMENT OF CRA ADVISORY BOARD MEMBERS AND COUNCIL LIAISON. Mayor Sheldon called for audience comments.

1 Ms. Genese Hatcher. Ms. Hatcher spoke of the parking issues within the CRA and destroying homes by taking away parking land in front of the homes. She asked that people "with skin in the game" be appointed to the Committee.

There were no further comments.

Councilman Casto made the motion to appoint Councilman Jarman as the Council Liaison. Second was by Councilman McConnell and the motion passed by unanimous roll call vote recorded as follows:

Councilman Jarman	Aye
Councilman Casto	Aye
Councilman Chester	Aye
Councilman McConnell	Aye
Mayor Sheldon	Aye

Councilman McConnell committee would not perform oversight and Mayor Sheldon disagreed. **The Council members then made their appointments:**

Councilman Jarman-	Debbie McCormick
Councilman McConnell-	Ben Faust
Councilman Chester-	Matt Bush
Councilman Casto-	Andy Gonsalves
Mayor Sheldon-	Clair Pease

ITEM 6 RESOLUTION 20-131, BEACH SAFETY SERVICES. Ms. Myers read Resolution 20-131 by title. Mayor Sheldon called for comments; there were none. Councilman McConnell urged reaching out to each hotel and have a conversation with them, not merely post the matter. Mayor Sheldon said all the beach should have lifeguards and that he hoped that with the revenue gained, the businesses would step up to work with the City. Councilman Casto agreed and added that Code Enforcement should issue the citations.

Councilman Casto made the motion to approve Resolution 20-131 with the changes. Second was by Councilman Jarman and the motion passed by unanimous roll call vote recorded as follows:

Councilman Jarman	Aye
Councilman Casto	Aye
Councilman Chester	Aye
Councilman McConnell	Aye
Mayor Sheldon	Aye

ITEM 7 RESOLUTION 20-132, BID AWARD- CITIZEN ENGAGEMENT STUDY AND BUDGET AMENDMENT #37. Ms. Myers read Resolution 20-132 by title. Mayor Sheldon called for comments; there were none. Mr. O'Rourke explained the survey and the critical exercise to solicit input from the citizens. In August, everyone in the City could respond online with more opportunity to add input. He added that the questions could be customized by the Council.

Councilman Jarman made the motion to approve Resolution 20-132. Second was by Councilman McConnell and the motion passed by unanimous roll call vote recorded as follows:

Councilman Jarman	Aye
Councilman Casto	Aye
Councilman Chester	Aye
Councilman McConnell	Aye
Mayor Sheldon	Aye

ITEM 8 RESOLUTION 20-128, BID AWARD- EAGLE DRIVE DRAINAGE IMPROVEMENTS. Ms. Myers read Resolution 20-128 by title. Mayor Sheldon called for comments.

1 Mr. Burnie Thompson. Mr. Thompson spoke of conflicts of interest with Mr. Robert Carroll as the engineer of record. He said he did not oppose the project but was

concerned that the project benefitted two Councilmen who lived in the neighborhood. He questioned how much was paid to Mr. Carroll.

Ms. Jenkins responded that the engineer of record made recommendations with GAC as the lowest bidder for the project. She said she did not know how much Mr. Carroll was paid. Ms. Myers added that Master Services Agreements for two firms were approved in 2013, with his firm being one.

Councilman Casto said he did not see this as a conflict. Ms. Myers said there was nothing illegal in this matter. The Mayor said the City had received multiple bids for the project and Councilman Chester said this was similar to the Bid-A-Wee project. Councilman Chester added that he did live in Colony Club and hopefully this improvement project would prevent some of the phone calls resulting from drains being clogged.

Councilman Chester made the motion to approve Resolution 20-128. Second was by Councilman Casto and the motion passed by unanimous roll call vote recorded as follows:

Councilman Jarman	Aye
Councilman Casto	Aye
Councilman Chester	Aye
Councilman McConnell	Aye
Mayor Sheldon	Aye

ITEM 9 WASTEWATER ODOR CONTROL- DISCUSSION. Mr. Mark Shaeffer, Utility Engineer, presented a powerpoint presentation related to the five highest odor source points, the Wastewater Treatment Facility, Lift Station 96, Lift Station 40, Lift Station 128 and Lift Station 73. He identified their various locations and explained the different treatment options.

Mayor Sheldon said it was prudent to actively do something. Councilman Casto said it was difficult to remove 100% of the odors and it was dangerous work with the corrosive hydrogen sulfide. He asked if the work would be guaranteed by the vendor and Mayor Sheldon said it would depend upon how it was written in the specifications that they would be held accountable. Councilman McConnell said sometimes the system was overwhelmed, and he was concerned that even after spending the money, the same problem would occur during the summer. Mayor Sheldon spoke of the five-year plan and the improvements planned during that time. Councilman Jarman asked if the complaints were overwhelmingly about the Treatment Facility as opposed to the various Lift Stations, and Mr. Shaeffer responded affirmatively. Discussion ensued concerning funding, and Mr. O'Rourke said it could be added into the upcoming budget. Mayor Sheldon said if the Utility Fund had the funds now, to move forward. Councilman McConnell concurred.

ITEM 10 BEACH ACCESS POINT GARBAGE RECEPTACLES- DISCUSSION. Mayor Sheldon called for comments.

1 Mr. Larry Messenger. Mr. Messenger said he supported the idea as the first step to elevate the cleanliness of the beach. He said the City needed to do more as there was too much litter.

2 Ms. Genese Hatcher. Ms. Hatcher said the main problem was Saturday checkout of the renters, putting out their garbage, and the hauler not coming until Monday. She suggested having another run on Saturday merely on Front Beach Road, which would pick up much of the garbage.

There were no further comments. Mayor Sheldon said the City could reach out to the haulers and asked if there would be any help from the TDC on roadside cans and daily pickups. He questioned if there would be grants available and funding. Councilman Casto spoke of rebuilding the beach accesses with cans beachside. He added that the boardwalks needed attention but the issue would be funding with the City's revenue down. He said the TDC was rebidding their hauler services next year, and maybe the specifications could be updated to include cleaning the accesses.

Mr. Campbell spoke of the CRA standards for the receptacles with weekends having many pizza boxes left on the ground because they would not fit into the cans. He said the CRA could budget for more cans along the accesses. Discussion ensued concerning litter in the dunes and along the walkways. Mr. O'Rourke said he would speak with the TDC President, Mr. Dan Rowe, and bring something back to the Council.

ITEM 11 PARKS AND RECREATION AMENITY UPGRADES- DISCUSSION.

Mayor Sheldon called for comments from the audience. There were none. Mr. O'Rourke spoke of a skateboard park and its huge demand. Councilman Jarman suggested a smaller venue compared to the one being built in the County. Mr. O'Rourke said something close for the kids that lived here. The Mayor agreed that the City should have our own as the County site was too far away. Mr. O'Rourke said Frank Brown Park would be a great location. Councilman Casto said he was concerned on the timing issue with revenue down. Mr. O'Rourke said we would wait for the response from the citizens survey. Mayor Sheldon added that more basketball courts would be great to see.

CITY MANAGER REPORT

Mr. O'Rourke spoke of the Strategic Plan with the ten focus groups, soliciting input from the citizens. He said Phase 1 was completed, and Phase 2 the draft plan next for the focus groups to review. He spoke of the Beach Safety matter and would be proactive in soliciting partnerships with businesses. He spoke of education on the rip currents. Mr. Rourke spoke of the Revenue Bonds 2012 upgrade, and the success of the hard work from staff and legal. He added that he anticipated a good field of candidates for the City Clerk position for the July 9th meeting. Related to grants, Mr. O'Rourke spoke of the upcoming RFP for a City representative at Tallahassee and Washington to leverage the State and Federal resources. Finally, he spoke of the new volunteer program which would provide a valuable service to the City and the community.

CITY ATTORNEY REPORT

None

COUNCIL COMMENTS

Councilman Casto had no comments. Councilman Chester had no comments. Councilman Jarman had no comments. Councilman McConnell thanked Ms. White and Ms. Myers for their work regarding the bonds and improving the Moody ratings. He urged the people to fill out the Census. Mayor Sheldon thanked Mr. O'Rourke for this work on the internship program. He said he wanted the City and its employees to be more involved with the school system and the mentor programs. He said he heard the community on the traffic situation and would try to find solutions. He congratulated Councilman Jarman for his appointment to the CRA Advisory Committee.

With nothing further, the meeting was adjourned at 11:20 A.M.

**** ACTION ITEMS NOTED WITH AN ASTERISK ARE TAKEN BOTH BY THE CITY COUNCIL AND THE PANAMA CITY BEACH REDEVELOPMENT AGENCY JOINTLY AND CONCURRENTLY.**

READ AND APPROVED this 23rd of July, 2020.

IN THE EVENT OF A CONFLICT BETWEEN THE FOREGOING MINUTES AND A VERBATIM TRANSCRIPT OF THESE MINUTES, THE FOREGOING MINUTES SHALL CONTROL.

ATTEST:

Mayor

City Clerk

DRAFT

PRESENTATIONS



~Proclamation~

A PROCLAMATION HONORING JULY 27TH
AS
"NATIONAL KOREAN WAR VETERANS ARMISTICE DAY"
IN PANAMA CITY BEACH

WHEREAS, sixty-five years after signing the Military Armistice Agreement at Panmunjom, Americans remain grateful for the courage and sacrifice of our Korean War Veterans. More than 600,000 United States and Allied combatants lost their lives in Korea during the three years of bitter warfare that ended on July 27, 1953; and

WHEREAS, these dedicated service men and women, under the banner of the United Nations, fought to secure the blessings of freedom and democracy on the Korean Peninsula, and they deserve our unending respect and gratitude; and

WHEREAS, today we remember and honor the valor of these Korean War veterans and the extraordinary sacrifices that they and their families made in the cause of peace;

WHEREAS, as American service men and women continue to support the cause for peace around the world, we honor the proud legacy of our remaining Korean War veterans who gave of themselves so that others might live in liberty; and

NOW, THEREFORE, the City Council of the City of Panama City Beach call upon all citizens of Panama City Beach to observe July 27, 2020 as

"National Korean War Veterans Armistice Day"

and encourage all Americans to recognize the valor and sacrifice of our Korean War veterans through ceremonies and prayers.

Mayor Mark Sheldon

Councilman Paul Casto
Ward 1



Councilman Phil Chester
Ward 2

Vice-Mayor Geoff McConnell
Ward 3

Councilman Michael Jarman
Ward 4

EMPLOYEE RECOGNITIONS- 7/23/20

25 Years

Richard McClanahan

COUNCILMAN CHESTER

10 Years

Gabe Moschella

Melanie McCormick

COUNCILMAN MCCONNELL

5 Years

Brent Gust

Joshua Wurst

Bradley Taylor

COUNCILMAN JARMAN

MAYOR SHELDON

Plaque presentations to:

Senator George Gainer

Representative Jay Trumbull

Floridian Partners, LLC

“In appreciation for distinguished representation of the City of Panama City Beach before the Florida Legislature during the 2020 Legislative Session and for securing critical Bay Parkway funding in the 2020-2021 Florida Budget.”

ITEM 1



CITY OF PANAMA CITY BEACH AGENDA ITEM SUMMARY

1. DEPARTMENT MAKING REQUEST/NAME:

Public Works/Kelly Jenkins

2. MEETING DATE:

07/23/2020

3. REQUESTED MOTION/ACTION:

Approve the Plat for the North Glades Commercial Development.

4. AGENDA

PRESENTATION
PUBLIC HEARING
CONSENT
REGULAR

5. IS THIS ITEM BUDGETED (IF APPLICABLE)? Yes No N/A
BUDGET AMENDMENT OR N/A

DETAILED BUDGET AMENDMENT ATTACHED Yes No N/A

6. BACKGROUND: (WHY IS THE ACTION NECESSARY, WHAT GOAL WILL BE ACHIEVED)

The City's Land Development Code requires most subdivisions of land to be platted in order to confirm compliance with the Code. The North Glades Commercial development is generally located northwest of the intersection of Panama City Beach Parkway and North Glades Trail. This plat will result in eight (8) commercial units. The infrastructure improvements within the commercial subdivision will remain private with the exception of the utilities that will be dedicated to the City. The public hearing to consider this plat has been publicly advertised and was continued from the 7/09/2020 City Council meeting. At the time of this memo, there are still outstanding items that must be addressed. There are a few minor outstanding items related to the approval of utilities for the development order. There are also outstanding items on the Plat itself. If all of this has not been completed by the time of the Council meeting, the Council may continue the hearing. If the plat meets the requirements of Florida Statutes by the time of the meeting, the Council may approve the plat with conditions to meet the City's additional requirements.

Staff has reviewed the subject plat and determined that, if addressed, it will meet applicable requirements.

NORTH GLADES COMMERCIAL

A SUBDIVISION OF A PORTION OF SECTION 25, TOWNSHIP 3 SOUTH, RANGE 16 WEST, CITY OF PANAMA CITY BEACH, BAY COUNTY, FLORIDA

JULY 2020

DEDICATION:
KNOW ALL MEN BY THESE PRESENTS, THAT BREAKFAST POINT COMMERCIAL, LLC, A FLORIDA LIMITED LIABILITY COMPANY, AS OWNER OF THE LAND DESCRIBED AND PLATON, HAS CAUSED SUCH LANDS TO BE SURVEYED AND SUBDIVIDED AS NORTH GLADES COMMERCIAL AND HEREBY DEDICATES ALL RIGHTS OF WAY, UTILITY EASEMENTS, DRAINAGE EASEMENTS AND STORMWATER MANAGEMENT FACILITIES TO THE 9th COMMUNITY ASSOCIATION.

OWNER, ITS SUCCESSORS AND ASSIGNS, HEREBY RESERVES THE RIGHT AND PRIVILEGE TO GRANT PERMISSIONS, UTILITY EASEMENTS FOR THE INSTALLATION AND MAINTENANCE (INCLUDING RIGHTS OF INGRESS AND EGRESS) OF SUCH UTILITY IMPROVEMENTS THAT ARE NECESSARY OR BENEFICIAL TO THE FUTURE OWNERS OF THE LANDS DESCRIBED HEREIN OR THE OWNERS OF ADJACENT LANDS.

OWNER, ITS SUCCESSORS AND ASSIGNS, SHALL HAVE THE RIGHT OF INGRESS AND EGRESS OVER ALL RIGHTS OF WAY, EASEMENTS AND STORMWATER MANAGEMENT FACILITIES FOR THE PURPOSE OF ACCESS, CONSTRUCTION OR MAINTENANCE OF THE PROPERTY OF OWNER AND OWNER'S AFFILIATES.

OWNER, HEREBY DEDICATES TO THE CITY OF PANAMA CITY BEACH, FLORIDA, EASEMENTS OVER ALL ROADS, STREETS, RIGHTS OF WAY, UTILITY EASEMENTS, DRAINAGE EASEMENTS, INCLUDING A 30 FOOT BYPASS DRAINAGE EASEMENT, AND STORMWATER MANAGEMENT FACILITIES DEPICTED ON THIS PLAT FOR THE PURPOSES OF INGRESS AND EGRESS, INSTALLATION, REPAIR, MAINTENANCE AND OPERATION OF UTILITIES.

LEGAL DESCRIPTION EAST PARCEL

A PARCEL OF LAND LYING AND BEING IN SECTION 25, TOWNSHIP 3 SOUTH, RANGE 16 WEST, BAY COUNTY, FLORIDA AND BEING MORE PARTICULARLY DESCRIBED AS FOLLOWS: COMMENCE AT THE SOUTHWEST CORNER OF SECTION 25, TOWNSHIP 3 SOUTH, RANGE 16 WEST, BAY COUNTY, FLORIDA AND PROCEED NORTH 00 DEGREES 41 MINUTES 14 SECONDS EAST, ALONG THE EAST BOUNDARY LINE OF SAID SECTION 25, FOR A DISTANCE OF 1034.35 FEET TO THE POINT OF BEGINNING; THENCE NORTH 00 DEGREES 41 MINUTES 14 SECONDS EAST, ALONG THE EAST BOUNDARY LINE OF SAID SECTION 25, FOR A DISTANCE OF 1034.35 FEET TO THE POINT OF BEGINNING; THENCE NORTH 00 DEGREES 41 MINUTES 14 SECONDS WEST, ALONG SAID NORTH RIGHT OF WAY LINE, FOR A DISTANCE OF 1034.35 FEET TO THE POINT OF BEGINNING; THENCE NORTH 00 DEGREES 41 MINUTES 14 SECONDS WEST, ALONG SAID NORTH RIGHT OF WAY LINE, FOR A DISTANCE OF 1034.35 FEET TO THE POINT OF BEGINNING; THENCE NORTH 00 DEGREES 41 MINUTES 14 SECONDS WEST, ALONG SAID NORTH RIGHT OF WAY LINE, FOR A DISTANCE OF 1034.35 FEET TO THE POINT OF BEGINNING; THENCE NORTH 00 DEGREES 41 MINUTES 14 SECONDS WEST, ALONG SAID NORTH RIGHT OF WAY LINE, FOR A DISTANCE OF 1034.35 FEET TO THE POINT OF BEGINNING; THENCE NORTH 00 DEGREES 41 MINUTES 14 SECONDS WEST, ALONG SAID NORTH RIGHT OF WAY LINE, FOR A DISTANCE OF 1034.35 FEET TO THE POINT OF BEGINNING; THENCE NORTH 00 DEGREES 41 MINUTES 14 SECONDS WEST, ALONG SAID NORTH RIGHT OF WAY LINE, FOR A DISTANCE OF 1034.35 FEET TO THE POINT OF BEGINNING; THENCE NORTH 00 DEGREES 41 MINUTES 14 SECONDS WEST, ALONG SAID NORTH RIGHT OF WAY LINE, FOR A DISTANCE OF 1034.35 FEET TO THE POINT OF BEGINNING.

LEGAL DESCRIPTION WEST PARCEL

A PARCEL OF LAND LYING AND BEING IN SECTION 25, TOWNSHIP 3 SOUTH, RANGE 16 WEST, BAY COUNTY, FLORIDA AND BEING MORE PARTICULARLY DESCRIBED AS FOLLOWS: COMMENCE AT THE SOUTHWEST CORNER OF SECTION 25, TOWNSHIP 3 SOUTH, RANGE 16 WEST, BAY COUNTY, FLORIDA AND PROCEED NORTH 00 DEGREES 41 MINUTES 14 SECONDS EAST, ALONG THE EAST BOUNDARY LINE OF SAID SECTION 25, FOR A DISTANCE OF 1034.35 FEET TO THE POINT OF BEGINNING; THENCE NORTH 00 DEGREES 41 MINUTES 14 SECONDS EAST, ALONG THE EAST BOUNDARY LINE OF SAID SECTION 25, FOR A DISTANCE OF 1034.35 FEET TO THE POINT OF BEGINNING; THENCE NORTH 00 DEGREES 41 MINUTES 14 SECONDS WEST, ALONG SAID NORTH RIGHT OF WAY LINE, FOR A DISTANCE OF 1034.35 FEET TO THE POINT OF BEGINNING; THENCE NORTH 00 DEGREES 41 MINUTES 14 SECONDS WEST, ALONG SAID NORTH RIGHT OF WAY LINE, FOR A DISTANCE OF 1034.35 FEET TO THE POINT OF BEGINNING; THENCE NORTH 00 DEGREES 41 MINUTES 14 SECONDS WEST, ALONG SAID NORTH RIGHT OF WAY LINE, FOR A DISTANCE OF 1034.35 FEET TO THE POINT OF BEGINNING; THENCE NORTH 00 DEGREES 41 MINUTES 14 SECONDS WEST, ALONG SAID NORTH RIGHT OF WAY LINE, FOR A DISTANCE OF 1034.35 FEET TO THE POINT OF BEGINNING; THENCE NORTH 00 DEGREES 41 MINUTES 14 SECONDS WEST, ALONG SAID NORTH RIGHT OF WAY LINE, FOR A DISTANCE OF 1034.35 FEET TO THE POINT OF BEGINNING; THENCE NORTH 00 DEGREES 41 MINUTES 14 SECONDS WEST, ALONG SAID NORTH RIGHT OF WAY LINE, FOR A DISTANCE OF 1034.35 FEET TO THE POINT OF BEGINNING.

WITNESSETH: BREAKFAST POINT COMMERCIAL, LLC

PRINTED NAME: DAN MORALES PRESIDENT

WITNESS: DATE SIGNED

ACKNOWLEDGMENT
STATE OF FLORIDA, COUNTY OF BAY
BEFORE ME, the undersigned authority, personally appeared BY PHYSICAL PRESENCE, DAN MORALES, AS PRESIDENT OF BREAKFAST POINT COMMERCIAL, LLC, THE OWNER OF THE UNDERSIGNED PROPERTY, PERSONALLY KNOWN TO ME OR WHO PRESENTED A VALID POWER OF ATTORNEY, AS IDENTIFICATION, AND WHO ACKNOWLEDGED TO ME THAT HE EXECUTED THE FOREGOING INSTRUMENT FOR THE PURPOSES INDICED THEREIN.

GIVEN UNDER MY HAND AND OFFICIAL SEAL, THIS DAY OF 2020.

NOTARY PUBLIC STATE OF MY COMMISSION EXPIRES: CITY COUNCIL APPROVAL:

WE, THE CITY COUNCIL OF THE CITY OF PANAMA CITY BEACH, HEREBY CERTIFY THAT THIS PLAT AND DEDICATION, TOGETHER WITH ALL CERTIFICATES SHOWN HEREON, HAVE BEEN EXAMINED BY REGULAR SESSION AND DULY APPROVED BY A MAJORITY OF THE COUNCIL AND HEREBY GRADED FILED FOR PERMANENT RECORDS THIS DAY OF 2020.

BY: MARK SHELDON - MAYOR
BY: PAUL CASTO - COUNCIL MEMBER, WARD 1
BY: PAUL CRESHER - COUNCIL MEMBER, WARD 2
BY: GARY MACGONNELL - COUNCIL MEMBER, WARD 3
BY: MICHAEL JAMES - COUNCIL MEMBER, WARD 4

CITY MANAGER'S CERTIFICATE
THIS IS TO CERTIFY THAT I, TONY O'DOUGHE, CITY MANAGER FOR THE CITY OF PANAMA CITY BEACH, FLORIDA, HAVE EXAMINED THIS PLAT, NORTH GLADES COMMERCIAL, AND FINDS THAT IT CONFORMS TO APPLICABLE REGULATIONS FOR SUBDIVISIONS WITHIN THE CITY OF PANAMA CITY BEACH, FLORIDA, SIGNED ON THIS THE DAY OF 2020.

BY: ANTHONY TONY O'DOUGHE CITY MANAGER CITY OF PANAMA CITY BEACH

CITY ENGINEER'S CERTIFICATE
THIS IS TO CERTIFY THAT I, KELLY P. JENKINS, CITY ENGINEER FOR THE CITY OF PANAMA CITY BEACH, FLORIDA, HAVE EXAMINED THIS PLAT, NORTH GLADES COMMERCIAL, AND FINDS THAT IT CONFORMS TO APPLICABLE REGULATIONS FOR SUBDIVISIONS WITHIN THE CITY OF PANAMA CITY BEACH, FLORIDA, SIGNED ON THIS THE DAY OF 2020.

BY: KELLY P. JENKINS, P.E. CITY ENGINEER CITY OF PANAMA CITY BEACH

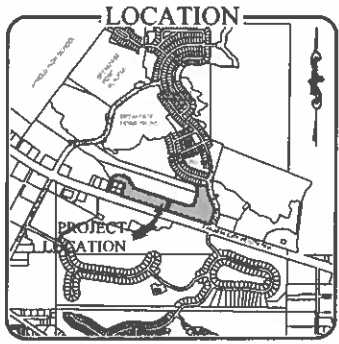

TITLE CERTIFICATE
FIDELITY NATIONAL TITLE INSURANCE COMPANY HEREBY CERTIFIES THAT UPON EXAMINATION OF THE PUBLIC RECORDS, THE TITLE TO THE LANDS DESCRIBED HEREON IS IN THE NAME OF BREAKFAST POINT COMMERCIAL, LLC, A FLORIDA LIMITED LIABILITY COMPANY, AND THERE ARE NO UNPAID MORTGAGES OR SAID LAND OTHER THAN AS SHOWN HEREON, RENDERED ON THE DAY OF 2020.

FIDELITY NATIONAL TITLE INSURANCE COMPANY
TITLE EXAMINER, STATE OF FLORIDA
NAME:

NOTES:
THIS PLAT, AS RECORDED IN ITS GRAPHIC FORM, IS THE OFFICIAL DEPICTION OF THE SUBDIVIDED LANDS DESCRIBED HEREON AND WILL IN NO CIRCUMSTANCES BE SUPPLANTED IN AUTHORITY BY ANY OTHER GRAPHIC OR DIGITAL FORM OF THE PLAT. THERE MAY BE ADDITIONAL REFERENCE NOTES THAT ARE NOT RECORDED ON THIS PLAT THAT MAY BE FOUND IN THE PUBLIC RECORDS OF THIS COUNTY.

NOTES:
ALL PLATTED UTILITY EASEMENTS, SHALL ALSO BE EASEMENTS FOR THE CONSTRUCTION, INSTALLATION, MAINTENANCE, AND OPERATION OF CABLE TELEVISION SERVICES, PROVIDED, HOWEVER, NO SUCH CONSTRUCTION, INSTALLATION, MAINTENANCE, AND OPERATION OF CABLE TELEVISION SERVICES SHALL INTERFERE WITH THE FACILITIES AND SERVICES OF AN ELECTRIC, TELEPHONE, GAS, OR ANY OTHER PUBLIC UTILITY. IN THE EVENT A CABLE TELEVISION COMPANY DAMAGES THE FACILITIES OF A PUBLIC UTILITY, IT SHALL BE SOLELY RESPONSIBLE FOR THE DAMAGES. THIS SECTION SHALL NOT APPLY TO THOSE PRIVATE EASEMENTS GRANTED TO OR OBTAINED BY A PARTICULAR ELECTRIC, TELEPHONE, GAS OR OTHER PUBLIC UTILITY, SUCH CONSTRUCTION, INSTALLATION, MAINTENANCE, AND OPERATION SHALL COMPLY WITH THE NATIONAL ELECTRICAL SAFETY CODE AS ADOPTED BY THE FLORIDA PUBLIC SERVICE COMMISSION.

TAX COLLECTOR'S CERTIFICATE
I, CHUCK PERDUE, DO HEREBY CERTIFY THAT TAXES HAVE BEEN PAID THROUGH TAX YEAR TO THE BEST OF MY KNOWLEDGE.
DATE: CHUCK PERDUE BAY COUNTY TAX COLLECTOR

CERTIFICATE OF CLERK
I, BILL SPITALS, CLERK OF THE CIRCUIT COURT OF BAY COUNTY, FLORIDA, HEREBY CERTIFY THAT THIS PLAT WAS FILED FOR PERMANENT RECORD ON THE DAY OF 2020 IN PLAT BOOK NO. 41 PAGE(S) 10 IN THE PUBLIC RECORDS OF BAY COUNTY, FLORIDA.

CITY SURVEYOR'S CERTIFICATE
I, KE TODD THRELL, CITY SURVEYOR UNDER CONTRACT TO AND FOR THE CITY OF PANAMA CITY BEACH, FLORIDA, HAVE REVIEWED THIS PLAT, NORTH GLADES COMMERCIAL, AND HEREBY CERTIFY THAT IT COMPLIES WITH ALL THE REQUIREMENTS OF CHAPTER 177, FLORIDA STATUTES, AND THAT PERMANENT REFERENCE MONUMENTS AND PERMANENT CONTROL POINTS HAVE BEEN SET.
SIGNED ON THIS THE DAY OF 2020.

SURVEYOR'S CERTIFICATE
I HEREBY CERTIFY THAT THIS PLAT, "NORTH GLADES COMMERCIAL", IS A TRUE AND CORRECT REPRESENTATION OF THE LANDS SURVEYED, THAT THIS PLAT WAS MADE UNDER MY RESPONSIBLE DIRECTION AND SUPERVISION, AND THAT THE SURVEY DATA AND THIS PLAT COMPLY WITH ALL THE REQUIREMENTS OF CHAPTER 177, FLORIDA STATUTES, AND THAT PERMANENT REFERENCE MONUMENTS AND PERMANENT CONTROL POINTS HAVE BEEN SET.
SIGNED ON THIS THE DAY OF 2020.

BY: DAVID JON BARTLEY, P.S.M. PROFESSIONAL SURVEYOR & MAPPER FLORIDA LICENSE NO. 15498

Dewberry
DEWBERRY ENGINEERS INC.
30 AMERIKEN PARKWAY
PANAMA CITY FLORIDA 32406
PHONE: 904.532.2844 FAX: 904.532.9111
CERTIFICATE OF AUTHORIZATION NO. 18011

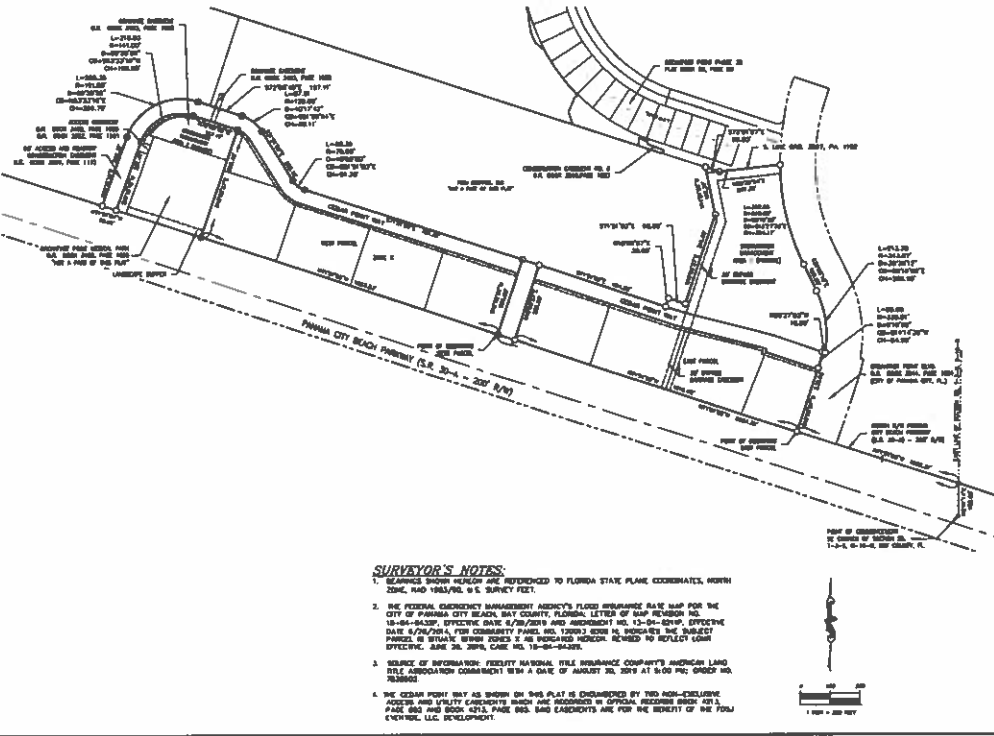

SURVEYOR'S NOTES:

- 1. BOUNDARY SHOWN HEREON ARE REFERENCED TO FLORIDA STATE PLANE COORDINATES, NORTH ZONE, NAD 1983, U.S. SURVEY FEET.
- 2. THE FEDERAL GOVERNMENT MANAGEMENT AGENCY'S FLOOD INSURANCE RATE MAP FOR THE CITY OF PANAMA CITY BEACH, BAY COUNTY, FLORIDA, LISTED AS MAP NUMBER NO. 15-04-0030P, EFFECTIVE DATE 4/29/2019 AND MODIFIED NO. 15-04-0030P, EFFECTIVE DATE 6/27/2019, FOR CONVEYANCE PANEL NO. 12002 DOES NOT WITHIN THE SUBJECT PARCELS. IN STATUTE WHEN ASSESSED IT IS RECORDED HEREON, PLEASE TO REFLECT CORRECT EFFECTIVE DATE 26, 2020, CASE NO. 15-06-00000.
- 3. SOURCE OF INFORMATION: FIDELITY NATIONAL TITLE INSURANCE COMPANY'S AMERICAN LAND TITLE ASSOCIATION COMMITMENT WITH A DATE OF AUGUST 20, 2019 AT 9:00 PM, CASE NO. 7818000.
- 4. THE CEDAR POINT PLOT AS SHOWN ON THIS PLAT IS OBTAINED BY TWO NON-EXCLUSIVE ACCESS AND UTILITY EASEMENTS FROM THE RECORDS IN OFFICIAL RECORDS BOOK 401, PAGE 682 AND BOOK 424, PAGE 884. SAID EASEMENTS ARE FOR THE BENEFIT OF THE TONY O'DOUGHE, LLC DEVELOPMENT.



NORTH GLADES COMMERCIAL

A SUBDIVISION OF A PORTION OF SECTION 25, TOWNSHIP 3 SOUTH, RANGE 16 WEST,
CITY OF PANAMA CITY BEACH, BAY COUNTY, FLORIDA

JULY 2020

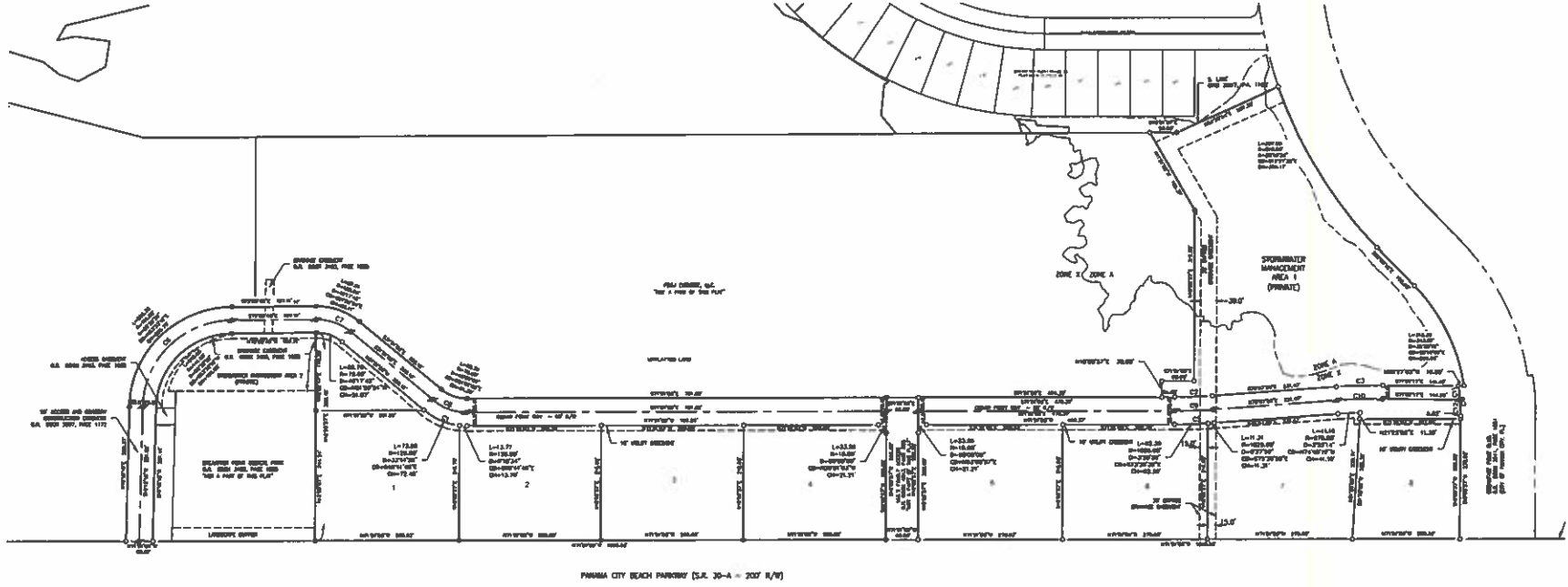

PANAMA CITY BEACH PARKWAY (S.L. 30-A - 207 R/W)

Curve Table					
Curve #	Length	Radius	Delta	Chord Bearing	Chord Length
C1	87.27	125.00	40°00'00"	S91°51'03"W	85.91
C2	70.02	975.00	4°38'53"	S73°54'30"E	70.00
C3	86.66	1025.00	4°30'38"	S73°32'39"E	86.63
C4	59.00	336.00	57°19'55"	S141°43'08"W	54.99
C5	73.81	1025.00	4°38'53"	S73°54'30"E	73.79
C6	296.69	100.00	88°35'59"	N63°33'18"E	231.87
C7	70.33	900.00	4°27'43"	S51°39'54"E	68.89
C8	66.81	1000.00	4°00'00"	S31°51'03"E	66.40
C9	71.81	1000.00	4°09'53"	S73°54'30"E	71.80
C10	84.33	1000.00	4°38'59"	N73°32'38"W	84.32
C11	23.20	336.00	4°18'20"	N114°21'31"E	23.20
C12	39.80	336.00	5°03'38"	N18°22'49"E	39.84

SYMBOLS & ABBREVIATIONS:

- L = ARC LENGTH
- R = RADIUS
- D = DELTA ANGLE
- CB = CHORD BEARING
- CL = CHORD LENGTH
- SA = OFFICIAL RECORDS
- R/W = RIGHT OF WAY
- = SET 3/4" CAPPED BORN ROD L.B. (8011)
- ⊕ = SET NAIL AND DISK L.B. (8011)
- = DISTANCE NOT TO SCALE
- L.B. = LICENSED SURVEYOR
- L.S. = LICENSED SURVEYOR
- T = TOWER
- B = BENCH
- N = NORTH
- S = SOUTH
- E = EAST
- W = WEST
- PH. = PHOTO
- DBM = OFFICIAL RECORDS BOOK



Dewberry
DEWBERRY ENGINEERS INC.
300 AME RICHEN PARKWAY
PANAMA CITY, FLORIDA 32409
PHONE 850.527.8844 FAX 850.527.1011
WWW.DEWBERRY.COM
CERTIFICATE OF AUTHORIZATION NO. LB 8011

LEGAL DESCRIPTION EAST PARCEL

A PARCEL OF LAND LYING AND BEING IN SECTION 25, TOWNSHIP 3 SOUTH, RANGE 16 WEST, BAY COUNTY, FLORIDA AND BEING MORE PARTICULARLY DESCRIBED AS FOLLOWS:

COMMENCE AT THE SOUTHEAST CORNER OF SECTION 25, TOWNSHIP 3 SOUTH, RANGE 16 WEST, BAY COUNTY, FLORIDA AND PROCEED NORTH 00 DEGREES 41 MINUTES 14 SECONDS EAST, ALONG THE EAST BOUNDARY LINE OF SAID SECTION 25, FOR A DISTANCE OF 109.03 FEET TO THE NORTH RIGHT OF WAY LINE OF PANAMA CITY BEACH PARKWAY (S.R. 30-A ~ 200' RIGHT OF WAY); THENCE NORTH 71 DEGREES 51 MINUTES 03 SECONDS WEST, ALONG SAID NORTH RIGHT OF WAY LINE, FOR A DISTANCE OF 1863.37 FEET TO THE WESTERLY RIGHT OF WAY LINE OF BREAKFAST POINT BLVD. AS RECORDED IN OFFICIAL RECORDS BOOK 3941, PAGE 1031 OF THE PUBLIC RECORDS OF BAY COUNTY, FLORIDA FOR THE POINT OF BEGINNING. THENCE CONTINUE NORTH 71 DEGREES 51 MINUTES 03 SECONDS WEST, ALONG SAID NORTH RIGHT OF WAY LINE, FOR A DISTANCE OF 1,010.95 FEET; THENCE LEAVING SAID NORTH RIGHT OF WAY LINE PROCEED NORTH 18 DEGREES 08 MINUTES 57 SECONDS EAST, FOR A DISTANCE OF 265.00 FEET; THENCE SOUTH 71 DEGREES 51 MINUTES 03 SECONDS EAST, FOR A DISTANCE OF 454.30 FEET; THENCE NORTH 18 DEGREES 08 MINUTES 57 SECONDS EAST, FOR A DISTANCE OF 30.00 FEET; THENCE SOUTH 71 DEGREES 51 MINUTES 03 SECONDS EAST, FOR A DISTANCE OF 60.00 FEET; THENCE NORTH 18 DEGREES 08 MINUTES 57 SECONDS EAST, FOR A DISTANCE OF 319.88 FEET; THENCE NORTH 11 DEGREES 51 MINUTES 03 SECONDS WEST, FOR A DISTANCE OF 169.37 FEET TO THE SOUTH LINE OF THAT PARCEL DESCRIBED IN OFFICIAL RECORDS BOOK 3867, PAGE 1192 OF THE PUBLIC RECORDS OF BAY COUNTY, FLORIDA; THENCE PROCEED EASTERLY ALONG SAID SOUTH LINE AS FOLLOWS: SOUTH 72 DEGREES 01 MINUTES 07 SECONDS EAST, FOR A DISTANCE OF 50.03 FEET; THENCE NORTH 83 DEGREES 38 MINUTES 54 SECONDS EAST, FOR A DISTANCE OF 207.32 FEET TO A POINT ON THE WEST RIGHT OF WAY LINE OF AFORESAID BREAKFAST POINT BLVD; POINT BEING ON A CURVE CONCAVE EASTERLY, HAVING A RADIUS OF 810.00 FEET, THROUGH A CENTRAL ANGLE OF 25 DEGREES 15 MINUTES 23 SECONDS; THENCE PROCEED SOUTHERLY ALONG SAID WEST RIGHT OF WAY LINE AND CURVE FOR AN ARC DISTANCE OF 357.05 FEET, (CHORD BEARING AND DISTANCE = SOUTH 13 DEGREES 27 MINUTES 33 SECONDS EAST, FOR A DISTANCE OF 354.17 FEET); THENCE CONTINUE ALONG SAID WEST RIGHT OF WAY LINE AS FOLLOWS: SOUTH 26 DEGREES 05 MINUTES 15 SECONDS EAST, FOR A DISTANCE OF 100.00 FEET TO A POINT ON A CURVE CONCAVE WESTERLY, HAVING A RADIUS OF 343.07 FEET, THROUGH A CENTRAL ANGLE OF 35 DEGREES 38 MINUTES 12 SECONDS; THENCE PROCEED SOUTHERLY ALONG SAID CURVE FOR AN ARC DISTANCE OF 213.38 FEET, (CHORD BEARING AND DISTANCE = SOUTH 08 DEGREES 16 MINUTES 09 SECONDS EAST, FOR A DISTANCE OF 209.96 FEET); THENCE NORTH 80 DEGREES 27 MINUTES 03 SECONDS WEST, FOR A DISTANCE OF 10.00 FEET TO A POINT ON A CURVE CONCAVE WESTERLY, HAVING A RADIUS OF 338.01 FEET, THROUGH A CENTRAL ANGLE OF 09 DEGREES 19 MINUTES 55 SECONDS; THENCE PROCEED SOUTHERLY ALONG SAID CURVE FOR AN ARC DISTANCE OF 55.05 FEET, (CHORD BEARING AND DISTANCE = SOUTH 14 DEGREES 14 MINUTES 39 SECONDS WEST, FOR A DISTANCE OF 54.99 FEET); THENCE SOUTH 18 DEGREES 08 MINUTES 57 SECONDS WEST, FOR A DISTANCE OF 230.02 FEET TO THE POINT OF BEGINNING.

CONTAINING 10.699 ACRES, MORE OR LESS.

AND

LEGAL DESCRIPTION WEST PARCEL

A PARCEL OF LAND LYING AND BEING IN SECTION 25, TOWNSHIP 3 SOUTH, RANGE 16 WEST, BAY COUNTY, FLORIDA AND BEING MORE PARTICULARLY DESCRIBED AS FOLLOWS:

COMMENCE AT THE SOUTHEAST CORNER OF SECTION 25, TOWNSHIP 3 SOUTH, RANGE 16 WEST, BAY COUNTY, FLORIDA AND PROCEED NORTH 00 DEGREES 41 MINUTES 14 SECONDS EAST, ALONG THE EAST BOUNDARY LINE OF SAID SECTION 25, FOR A DISTANCE OF 109.03 FEET TO THE NORTH RIGHT OF WAY LINE OF PANAMA CITY BEACH PARKWAY (S.R. 30-A ~ 200' RIGHT OF WAY); THENCE NORTH 71 DEGREES 51 MINUTES 03 SECONDS WEST, ALONG SAID NORTH RIGHT OF WAY LINE, FOR A DISTANCE OF 2934.32 FEET TO THE POINT OF BEGINNING. THENCE CONTINUE NORTH 71 DEGREES 51 MINUTES 03 SECONDS WEST, ALONG SAID NORTH RIGHT OF WAY LINE, FOR A DISTANCE OF 1,063.53 FEET; THENCE LEAVING SAID NORTH RIGHT OF WAY LINE PROCEED NORTH 18 DEGREES 08 MINUTES 57 SECONDS EAST, FOR A DISTANCE OF 390.45 FEET; THENCE NORTH 72 DEGREES 08 MINUTES 45 SECONDS WEST, FOR A DISTANCE OF 157.11 FEET TO A POINT ON A CURVE CONCAVE SOUTHEASTERLY, HAVING A RADIUS OF 141.00 FEET, THROUGH A CENTRAL ANGLE OF 88 DEGREES 35 MINUTES 56 SECONDS; THENCE PROCEED SOUTHWESTERLY ALONG SAID CURVE FOR AN ARC DISTANCE OF 218.03 FEET, (CHORD BEARING AND DISTANCE = SOUTH 63 DEGREES 33 MINUTES 16 SECONDS WEST, FOR A DISTANCE OF 196.95 FEET); THENCE SOUTH 19 DEGREES 15 MINUTES 18 SECONDS WEST, FOR A DISTANCE OF 251.41 FEET TO A POINT ON THE AFORESAID NORTH RIGHT OF WAY LINE OF PANAMA CITY BEACH PARKWAY; THENCE NORTH 71 DEGREES 51 MINUTES 04 SECONDS WEST, ALONG SAID NORTH RIGHT OF WAY LINE, FOR A DISTANCE OF 50.01 FEET; THENCE LEAVING SAID NORTH RIGHT OF WAY LINE PROCEED NORTH 19 DEGREES 15 MINUTES 18 SECONDS EAST, FOR A DISTANCE OF 252.37 FEET TO A POINT ON A CURVE CONCAVE SOUTHEASTERLY, HAVING A RADIUS OF 191.00 FEET, THROUGH A CENTRAL ANGLE OF 88 DEGREES 35 MINUTES 56 SECONDS; THENCE PROCEED NORTHEASTERLY ALONG SAID CURVE FOR AN ARC DISTANCE OF 295.35 FEET, (CHORD BEARING AND DISTANCE = NORTH 63 DEGREES 33 MINUTES 16 SECONDS EAST, FOR A DISTANCE OF 266.79 FEET); THENCE SOUTH 72 DEGREES 08 MINUTES 45 SECONDS EAST, FOR A DISTANCE OF 157.11 FEET TO A POINT ON A CURVE CONCAVE SOUTHWESTERLY, HAVING A RADIUS OF 125.00 FEET, THROUGH A CENTRAL ANGLE OF 40 DEGREES 17 MINUTES 42 SECONDS; THENCE PROCEED SOUTHEASTERLY ALONG SAID CURVE FOR AN ARC DISTANCE OF 87.91 FEET, (CHORD BEARING AND DISTANCE = SOUTH 51 DEGREES 59 MINUTES 54 SECONDS EAST, FOR A DISTANCE OF 86.11 FEET); THENCE SOUTH 31 DEGREES 51 MINUTES 03 SECONDS EAST, FOR A DISTANCE OF 200.16 FEET TO A POINT ON A CURVE CONCAVE NORTHEASTERLY, HAVING A RADIUS OF 75.00 FEET, THROUGH A CENTRAL ANGLE OF 40 DEGREES 00 MINUTES 00 SECONDS; THENCE PROCEED SOUTHEASTERLY ALONG SAID CURVE FOR AN ARC DISTANCE OF 52.36 FEET, (CHORD BEARING AND DISTANCE = SOUTH 51 DEGREES 51 MINUTES 03 SECONDS EAST, FOR A DISTANCE OF 51.30 FEET); THENCE SOUTH 71 DEGREES 51 MINUTES 03 SECONDS EAST, FOR A DISTANCE OF 781.26 FEET; THENCE SOUTH 18 DEGREES 08 MINUTES 57 SECONDS WEST, FOR A DISTANCE OF 265.00 FEET TO THE POINT OF BEGINNING. CONTAINING 7.837 ACRES, MORE OR LESS.

ITEM 2



CITY OF PANAMA CITY BEACH AGENDA ITEM SUMMARY

1. DEPARTMENT MAKING REQUEST/NAME:

Building and Planning Department

2. MEETING DATE:

07/23/2020

3. REQUESTED MOTION/ACTION:

The Council is requested to approve the recommended changes to the Comprehensive Plan and the Land Development Code to maintain consistency with height limits recommended by Naval Support Activity - Panama City and the State.

4. AGENDA

PRESENTATION
PUBLIC HEARING
CONSENT
REGULAR

5. IS THIS ITEM BUDGETED (IF APPLICABLE)? YES NO N/A
BUDGET AMENDMENT OR N/A

DETAILED BUDGET AMENDMENT ATTACHED YES NO N/A

6. BACKGROUND: (WHY IS THE ACTION NECESSARY, WHAT GOAL WILL BE ACHIEVED)

Local governments in the State, which are located in close proximity to a military installation, are required to adopt policies in their Comprehensive Plan and Land Development Code which address compatibility and facilitate the continued presence of the major military installation. The City adopted such policies in 2012 which included a 250-foot building height limitation within the Naval Support Activity - Panama City (NSA-PC) Microwave Tower Line-of-Sight. There is one microwave tower at NSA-PC that provides critical communication and radar linkage to the Eglin/Gulf Range Complex as well as between Eglin Air Force Base and Tyndall Air Force Base.

NSA-PC and the Florida Department of Economic Opportunity have requested the City amend the maximum height in this zone to 230 feet (20-foot height reduction) to match the maximum building heights permitted in the unincorporated areas of the County and to continue to protect the mission of NSA-PC. The previous version of the Ordinance considered by the City Council placed the requirements in the Comprehensive Plan but placed the specific regulations in the Land Development Code to prevent duplication. NSA-PC and the Florida Department of Economic Opportunity prefer to see duplicate language in the Comprehensive Plan and the Land Development Code. As such, staff has amended the Ordinance to include such duplicate language. The change is not substantive such that readings of the Ordinance need to restart.

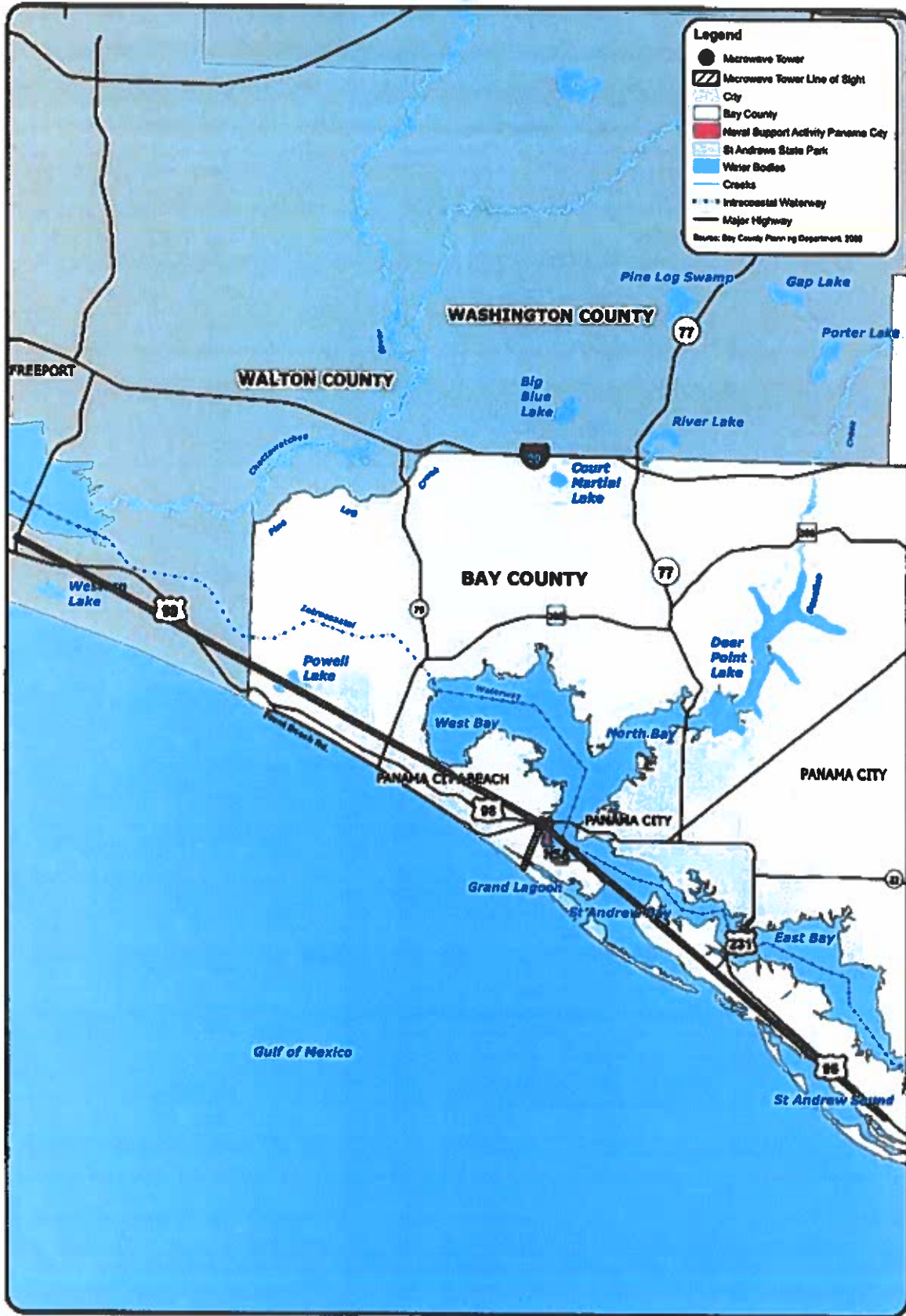

Regional Microwave Tower Line-of-Sight
Figure 3-2

Bay County JLUS

ORDINANCE 1518

AN ORDINANCE OF THE CITY OF PANAMA CITY BEACH, RELATED TO THE NAVAL SUPPORT ACTIVITY PANAMA CITY MILITARY INFLUENCE OVERLAY DISTRICT; AMENDING THE CITY'S COMPREHENSIVE GROWTH DEVELOPMENT PLAN AND LAND DEVELOPMENT CODE TO REDUCE THE MAXIMUM HEIGHT OF FACILITIES IN THE WEST MICROWAVE TOWER CORRIDOR OF THE NAVAL SUPPORT ACTIVITY PANAMA CITY MILITARY INFLUENCE OVERLAY DISTRICT; REPEALING ORDINANCES IN CONFLICT; PROVIDING FOR CODIFICATION; AND PROVIDING AN EFFECTIVE DATE.

BE IT ORDAINED BY THE CITY COUNCIL OF THE CITY OF PANAMA CITY BEACH:

SECTION 1. From and after the effective date of this ordinance, Future Land Use Element Policy 1.4.L.2.E, SECTION 3 of the Ordinance 1143, known as the 2009 Amended and Restated Panama City Beach Comprehensive Growth Development Plan, is amended to read as follows(new text **bold and underlined**, deleted text ~~struckthrough~~):

SECTION 3

FUTURE LAND USE ELEMENT

...

L. Naval Support Activity Panama City Military Influence Overlay District

The Naval Support Activity Panama City Military Influence Overlay District (NSAPC MIOD) shall be established to ensure that the continually changing missions of the local military installations are facilitated to the greatest extent possible. The City shall support the U.S. Navy in its operation of Naval Support Activity Panama City (NSAPC) so that the facilities remain viable and able to fulfill their missions. Three Military Influence Areas (MIAs) shall also be established to encourage compatible land use patterns, protect the public health, safety and general welfare, and help prevent encroachment from incompatible development.

1. **The NSAPC Military Influence Overlay District (NSAPC MIOD):** The NSAPC Military Influence Overlay District shall be the area located on Exhibit 16. The NSAPC MIOD includes the following Military Influence Areas: The NSAPC Land Use and Anti-Terrorism Force Protection Military Influence Area, depicted on Exhibit 17; the NSAPC Land Use Water Interface Military Influence Area, depicted on Exhibit 18; and, the NSAPC Frequency Military Influence Area depicted on Exhibit 19.

2. **Application Coordination:** In order to ensure that the City's long range land use plans are consistent with the operation of NSAPC, the City shall create an ex officio non-voting member position on its Local Planning Agency (aka Planning Board) for NSAPC. The City shall notify the commanding officer (or their appointed representatives) of NSAPC of any proposed Comprehensive Plan amendments (map or text), re-zoning applications, variances, conditional use permits, applications for development orders, and amendments to the City's Land Development Code which are proposed in or affect any area found to be in the NSAPC MIOD on Exhibit 16. The City shall consider NSAPC's input and concerns during its review of such planning, regulatory and development proposals. The City shall also assess the compatibility of such planning, regulatory and development proposal as provided in the following criteria:
 - a. Whether such proposal is compatible with the findings of the Naval Support Activity Panama City Joint Land Use Study, November 2009;
 - b. Whether the military installation's mission will be adversely affected by the proposal;
 - c. Whether such proposal creates any frequency interferences that are incompatible with the current mission of NSAPC. To implement this provision, the City shall ensure that all future commercial and

industrial development located inside the NSAPC Frequency Military Influence Area (Exhibit 19) shall register with the Planning Department and specifically describe any frequency spectrum that is generated or emitted by the proposal.

- d. Whether such proposal is compatible with the NSAPC water based activities. To implement this provision, the City shall ensure that all applications for development orders, including docks, piers, boat slips, boat launches, and marinas located within the NSAPC Land Use Water Interface Military Influence Area (Exhibit 18) shall be submitted to the Planning Department to review for compliance with this provision.
- e. Whether such proposal is compatible with the mission of the NSAPC based on the NSAPC Land Use and Anti-Terrorism Force Protection Military Influence Area. A component of this Influence area is the West Microwave Tower Corridor. Within this corridor a ~~230~~250-foot height limitation shall be enforced to prevent vertical obstructions and ensure noninterference with signal pathways and critical communication lines. Any building or structure, including chimneys; water, fire, radio, and television towers; smokestacks; flagpoles; and similar structures and their necessary mechanical appurtenances, such as elevator shafts, and ventilation equipment shall be limited to ~~230~~250 feet in height. The NSAPC Land Use and Anti-Terrorism Force Protection Military Influence Area is geographically depicted on (Exhibit 17).
- f. Nothing herein shall be construed to limit the ability of NSAPC to request a review of an application, when such application may, in the opinion of NSAPC, present a potential conflict in compatibility.

SECTION 2. From and after the effective date of this ordinance, Section 7.02.06.C.2.e. of the City's Land Development Code, is amended to read as follows(new text **bold and underlined**, deleted text ~~struckthrough~~):

7.02.06 Naval Support Activity Panama City Military Influence Overlay District

A. Purpose

The Naval Support Activity Panama City Military Influence Overlay District (NSA-PC MIOD) is established to ensure that the continually changing missions of the local military installations are facilitated to the greatest extent possible. The City shall support the U.S. Navy in its operation of Naval Support Activity Panama City (NSA-PC) so that the facilities remain viable and able to fulfill their missions. The district and the three (3) Military Influence Areas are established to encourage compatible land use patterns, protect the public health, safety and general welfare, and help prevent encroachment from incompatible development.

B. Boundaries

The NSA-PC Military Influence Overlay District (NSA-PC MIOD): The NSA-PC Military Influence Overlay District which corresponds with the area located on Exhibit 16 of the Comprehensive Plan and as shown on the **Zoning Map**. The NSA-PC MIOD includes the following Military Influence Areas as shown in the referenced exhibits of the Comprehensive Plan: The NSA-PC Land Use and Anti-Terrorism Force Protection Military Influence Area, depicted on Exhibit 17; the NSA-PC Land Use Water Interface Military Influence Area, depicted on Exhibit 18; and the NSA-PC Frequency Military Influence Area depicted on Exhibit 19.

C. Application Coordination

1. The **City** shall notify the commanding officer (or their appointed representatives) of NSA-PC of any proposed Comprehensive Plan amendments (map or text), amendments to this **LDC** or applications for **Development Orders** that are proposed in or affect any area found to be in the NSA-PC MIOD.
2. The **City** shall consider NSA-PC's input and concerns during its review of such planning, regulatory and development proposals. The **City** also shall assess the compatibility of any planning, regulatory and development proposal as provided in the following criteria:
 - (a) Whether such proposal is compatible with the findings of the Naval Support Activity Panama City Joint Land Use Study, November 2009;
 - (b) Whether the military installation's mission will be adversely affected by the proposal;

- (c) Whether such proposal creates any frequency interferences that are incompatible with the current mission of NSA-PC. To implement this provision, the City shall ensure that all future commercial and industrial development located inside the NSA-PC Frequency Military Influence Area shall register with the Planning Department and specifically describe any frequency spectrum that is generated or emitted by the proposal.
 - (d) Whether such proposal is compatible with the NSA-PC water based activities. To implement this provision, the City shall ensure that all applications for development orders, including docks, piers, boat slips, boat launches, and marinas located within the NSA-PC Land Use Water Interface Military Influence Area shall be submitted to the Planning Department to review for compliance with this provision.
 - (e) Whether such proposal is compatible with the mission of the NSA-PC based on the NSA-PC Land Use and Anti-Terrorism Force Protection Military Influence Area. A component of this Influence area is the West Microwave Tower Corridor. Within this corridor a ~~230~~ 250-foot height limitation shall be enforced to prevent vertical obstructions and ensure noninterference with signal pathways and critical communication lines. Any building or structure, including chimneys; water, fire, radio, and television towers; smokestacks; flagpoles; and similar structures and their necessary mechanical appurtenances, such as elevator shafts, and ventilation equipment shall be limited to 230 ~~250~~ feet in height.
3. Nothing herein shall be construed to limit the ability of NSA-PC to request a review of an application for a **Development Order**, when such application may, in the opinion of NSA-PC, present a potential conflict in compatibility.

SECTION 3. All ordinances or parts of ordinances in conflict herewith are repealed to the extent of such conflict.

SECTION 4. This Ordinance shall take effect as provided by law.

PASSED, APPROVED AND ADOPTED at the regular meeting of the City Council of the City of Panama City Beach, Florida, this ____ day of _____, 2020.

Mark Sheldon, MAYOR

ATTEST:

Jo Smith, INTERIM CITY CLERK

EXAMINED AND APPROVED by me this ____ day of _____, 2020.

MAYOR

PUBLISHED in the Panama City News Herald on the 29th day of April, 2020 and the 14th day of July, 2020.

POSTED on pcbgov.com on the ____ day of _____, 2020.

ITEM 3



CITY OF PANAMA CITY BEACH AGENDA ITEM SUMMARY

1. DEPARTMENT MAKING REQUEST/NAME:
CITY MANAGER / TONY O'ROURKE

2. MEETING DATE:
JULY 23, 2020

3. REQUESTED MOTION/ACTION:
APPROVE FIRST READING OF ORDINANCE 1535 WHICH RATIFIES ORDINANCE 1531-E RELATED TO CODE ENFORCEMENT.

4. AGENDA

PRESENTATION
PUBLIC HEARING
CONSENT
REGULAR

5. IS THIS ITEM BUDGETED (IF APPLICABLE)? Yes No N/A
BUDGET AMENDMENT OR N/A

DETAILED BUDGET AMENDMENT ATTACHED Yes No N/A

6. BACKGROUND: (WHY IS THE ACTION NECESSARY, WHAT GOAL WILL BE ACHIEVED)

AT ITS JULY 9, 2020, MEETING THE CITY COUNCIL ENACTED ORDINANCE 1531-E AUTHORIZING CODE ENFORCEMENT TO ENFORCE ALL VIOLATIONS OF CITY ORDINANCE CONSISTENT WITH FLORIDA STATUTES AND IMPLEMENTS THIS RESOURCE IMMEDIATELY ON AN EMERGENCY BASIS. CODE ENFORCEMENT WILL BE CHIEFLY DEPLOYED TO THE BEACH TO ENFORCE THE CITY'S BEACH SAFETY ORDINANCES.

AS AN EMERGENCY ORDINANCE, THIS WAS PASSED BY A 2/3 MAJORITY AND MADE IMMEDIATELY EFFECTIVE. ORDINANCE 1535 RATIFIES THAT ORDINANCE AS A PERMANENT ORDINANCE UNDER THE PROCEDURES SET FORTH BY FLORIDA STATUTES.

IF APPROVED ON FIRST READING, STAFF WILL SCHEDULE THIS ORDINANCE FOR A PUBLIC HEARING AND ADOPTION.

ORDINANCE 1535

AN ORDINANCE OF THE CITY OF PANAMA CITY BEACH, FLORIDA, AUTHORIZING THE ENFORCEMENT OF ALL CITY ORDINANCES BY CODE ENFORCEMENT OFFICERS SUBJECT TO PENALTIES AND PROCEDURES SET FORTH IN THE CITY'S CODE OF ORDINANCES AUTHORIZING CODIFICATION; REPEALING ORDINANCES OR PARTS OF ORDINANCES IN CONFLICT; AND PROVIDING AN EFFECTIVE DATE.

BE IT ENACTED BY THE CITY COUNCIL OF THE CITY OF PANAMA CITY BEACH, FLORIDA, AS FOLLOWS:

SECTION 1 From and after the effective date of this ordinance, Section 1-12, of the Panama City Beach Code of Ordinances is amended to read as follows (new text **bold and underlined**, deleted text struck through):

Sec. 1-12. - General penalty; continuing violations, **enforcement**.

- (a) Whenever in this Code or the ordinance of the city any act is prohibited or is made or declared to be unlawful or an offense, or whenever in this Code or the ordinances of the city the doing of any act is required, or the failure to do any act is declared to be unlawful, where no specific penalty is provided therefor, the violation of any such provision of this Code or the ordinances of the city shall be punished by a fine not exceeding five hundred dollars (\$500.00), imprisonment in a lawful place for a term not exceeding sixty (60) days, probation with terms set by the court, or by any combination thereof including all three in the discretion of the court. This section shall not apply to offenses which are recognized by the laws of the state as misdemeanors, the penalties for which are provided by the laws of the state, which state penalties shall likewise be applicable under this Code. Each day any violation of any of the provisions of this Code or of any ordinance of the city shall continue shall constitute a separate offense.
- (b) In addition to the penalties provided in subsection (a), any condition caused or permitted to exist in violation of any of the provisions of this code and the ordinances of the city shall be deemed a public nuisance and may be abated by the city as provided by law, and each day that any such offensive condition continues shall be regarded as a new and separate offense.
- (c) **Any violation of municipal ordinance may be enforced by civil citation by an employee of the City designated as a code enforcement officer by the City**

Manager. Any violation of a provision of this Code, the City's Land Development Code, or any other ordinance of the City shall be punishable by the penalties set forth in section (a) of this Section or as specifically set forth in the body of the Code, ordinance, or resolution. This grant of authority shall be cumulative and supplemental to any enforcement powers granted to Police and Fire Department employees as more specifically set forth throughout this Code.

(d) Any violation of municipal ordinance which is not adjudicated through administrative procedures set forth in the body of the ordinance shall be adjudicated in the County Court of Bay County pursuant to section 34.01, Florida Statutes.

(Code 1973, §§ 1-8, 1-9; Ord. No. 208, § II, 5-24-78; Ord. No. 570, § 1, 5-15-98)

Cross reference— Nuisances, Ch. 15; offenses, Ch. 16.

State Law reference— Fines and forfeiture in county court payable to municipality, F.S. § 34.191; enforcement by code inspectors §166.0415; punishment for misdemeanors, F.S. §§ 775.082, 775.083.

SECTION 2. SEVERABILITY. If any clause or portion of this Ordinance is held invalid or unenforceable, the remainder of this Ordinance shall continue in full force and effect.

SECTION 3. All ordinances or parts of ordinances in conflict herewith are repealed to the extent of such conflict.

SECTION 4. The appropriate officers and agents of the City are authorized and directed to codify, include and publish in electronic format the provisions of this Ordinance within the Panama City Beach Code, and unless a contrary ordinance is adopted within ninety (90) days following such publication, the codification of this Ordinance shall become the final and official record of the matters herein ordained. Section numbers may be assigned and changed whenever necessary or convenient.

SECTION 5. EFFECTIVE DATE. This Ordinance shall take effect immediately upon passage.

THIS ORDINANCE shall be effective immediately upon passage.

PASSED in regular session this ___ day of _____, 2020.

CITY OF PANAMA CITY BEACH

By: _____
Mark Sheldon, Mayor

ATTEST:

Jo Smith, Interim City Clerk

ITEM 4



CITY OF PANAMA CITY BEACH AGENDA ITEM SUMMARY

1. DEPARTMENT MAKING REQUEST/NAME:

CODE ENFORCEMENT / MEL LEONARD

2. MEETING DATE:

JULY 23, 2020

3. REQUESTED MOTION/ACTION:

APPROVE FIRST READING OF ORDINANCE 1534 PROHIBITING PERSONAL PROPERTY ALONG THE EMERGENCY LANE OF THE SANDY BEACH DURING DOUBLE RED FLAGS.

4. AGENDA

PRESENTATION
PUBLIC HEARING
CONSENT
REGULAR

5. IS THIS ITEM BUDGETED (IF APPLICABLE)? Yes No N/A
BUDGET AMENDMENT OR N/A

DETAILED BUDGET AMENDMENT ATTACHED Yes No N/A

6. BACKGROUND: (WHY IS THE ACTION NECESSARY, WHAT GOAL WILL BE ACHIEVED)

THE CITY'S CURRENT CODE PROHIBITS COMMERCIAL PROPERTY WITHIN THIRTY (30) FEET LANDWARD OF THE "WET SAND" TO PREVENT OBSTACLES TO EMERGENCY AND OTHER PERMITTED VEHICLES.

WITH THE PASSAGE OF ORDINANCE 1494 WHICH ENHANCED BEACH SAFETY DURING DOUBLE RED FLAGS, STAFF HAS COMMONLY UTILIZED THIS WATER'S EDGE LANE TO SPOT DISTRESSED SWIMMERS AND OTHERS WHO WOULD ENTER THE WATER DURING THESE HIGHLY DANGEROUS CONDITIONS.

WHEN PATROLLING THE BEACH DURING DOUBLE RED FLAGS, THIS LANE IS OFTEN OBSTRUCTED BY PERSONAL PROPERTY PLACED ALONG THIS LANE BY RESIDENTS AND VISITORS. THIS PRIMARILY CONSISTS OF BEACH CHAIRS, TENTS, AND UMBRELLAS. WHILE THIS PROPERTY IS GENERALLY WELCOME ALONG THE BEACH, STAFF REQUESTS THAT THIS LANE BE KEPT FREE FROM OBSTRUCTIONS ONLY DURING DOUBLE RED FLAGS.

STAFF RECOMMENDS APPROVAL. IF APPROVED, THIS ORDINANCE WILL BE SCHEDULED FOR A PUBLIC HEARING AND FINAL ADOPTION.

ORDINANCE 1534

AN ORDINANCE OF THE CITY OF PANAMA CITY BEACH, FLORIDA, AMENDING CHAPTER 7 OF THE CITY'S CODE OF ORDINANCES RELATING TO BEACH SAFETY DURING DOUBLE RED FLAGS; PROHIBITING PERSONAL PROPERTY WITHIN AN EMERGENCY LANE ON THE SANDY GULF BEACH DURING DOUBLE RED FLAGS; PROVIDING FOR PENALTIES AND ENFORCEMENT; AUTHORIZING CODIFICATION; REPEALING ORDINANCES OR PARTS OF ORDINANCES IN CONFLICT; AND PROVIDING AN EFFECTIVE DATE.

WHEREAS, the Florida Department of Environmental Protection has adopted a uniform warning flag program for use by Florida's beachfront communities, which system is intended to minimize the risks of drowning or serious injury; and

WHEREAS, the City prominently displays signs at its beach accesses and in transient dwelling accommodations to educate beachgoers of the flag system and hazard signified by such flags, and flies flags up and down its nine miles of beaches to indicate the Gulf conditions; and

WHEREAS, double red flags signify the water is closed to the public; and

WHEREAS, swimmers who enter the water in dangerous conditions risk not only their own lives but the lives of those attempting to rescue distressed swimmers; and

WHEREAS, on August 8, 2019, the City passed Ordinance 1494 which authorized City personnel to order persons to stay out or come out of the Gulf of Mexico during double red flags; and

WHEREAS, since that time the City has found it effective to use the beach landward of the wet sand as an emergency lane to spot swimmers in distress and to educate residents and visitors on the dangers of the Gulf of Mexico during double red flags; and

WHEREAS, the City finds that this emergency lane, already free of commercial personal property, is frequently obstructed by tents, chairs, and umbrellas from visitors enjoying the beach; and

WHEREAS, the City Council finds that during these especially dangerous times, there is a compelling reason to keep this emergency lane free of obstructions in furtherance of the public health, safety, and welfare.

NOW THEREFORE, BE IT ENACTED BY THE PEOPLE OF THE CITY OF PANAMA CITY BEACH:

SECTION 1. From and after the effective date of this Ordinance, Section 7-12 of the City's Code of Ordinances is amended to read as follows:

Section 7-12. ~~Failure to obey lawful order.~~ Double Red Flags

- (a) The legislative intent of this section is to authorize City personnel to order persons to stay out of or come in from the Gulf of Mexico when double red flags are flying.
- (b) Failure to obey an order to stay out of or come in from the Gulf of Mexico by a police officer, when reasonably known to be such an official, is hereby prohibited and made unlawful. Such order shall be made for the purpose of ensuring the safety of persons using the beach or waters of the Gulf of Mexico. Any person violating any provision of this section may be punished as follows:
 - 1. First Offense: verbal warning.
 - 2. Second Offense (occurring within twenty-four hours but following an opportunity to comply with the preceding warning): Misdemeanor of the second degree punishable by a fine of no more than \$500, or a sentence of not more than sixty (60) days in jail, or both.
- (c) Failure to obey an order to stay out of or come in from the Gulf of Mexico by any member of the City's fire rescue department or Code Enforcement Department, when reasonably known to be such a person, is hereby prohibited and made unlawful. Any person violating any provision of this section may be punished as follows:
 - 1. First Offense: warning
 - 2. Second Offense: by a civil penalty of \$250.
 - 3. Third Offense: by a civil penalty of \$500.
- (d) All fire rescue personnel of the City shall be considered code enforcement officers for the purpose of enforcing this section. A

citation issued under section (b) may be contested in accordance with the provisions of Chapter 25 of the City's Code of Ordinance.

- (e) This section shall not apply to persons attached by a leash to a surfboard. A surfboard means a fiberglass, epoxy, closed-cell neoprene or closed cell Styrofoam instrument with one or more fins or skegs attached to or inserted through the bottom, including windsurf boards and sailboards, but does not include rubber rafts, floats, belly boards, skim boards, or boogie boards.
- (f) During double red flags, no personal property, including but not limited to chairs, umbrellas, and tents, may be placed within thirty (30) feet landward of the primary wrack line or, if there be no primary wrack line, the scarf line or landward edge of the "wet sand" so as to avoid being an obstacle to City vehicles. Any violation of this subsection is punishable in the same manner set forth in subsection (c) of this section.**

SECTION 2. All ordinances or parts of ordinances in conflict herewith are repealed to the extent of such conflict.

SECTION 3. The appropriate officers and agents of the City are authorized and directed to codify, include and publish in electronic format the provisions of this Ordinance within the Panama City Beach Code, and unless a contrary ordinance is adopted within ninety (90) days following such publication, the codification of this Ordinance shall become the final and official record of the matters herein ordained. Section numbers may be assigned and changed whenever necessary or convenient.

SECTION 4. This Ordinance shall take effect immediately upon passage.

PASSED, APPROVED AND ADOPTED at the regular meeting of the City Council of the City of Panama City Beach, Florida, this ____ day of _____, 2020.

MAYOR

ATTEST:

CITY CLERK

EXAMINED AND APPROVED by me this ____ day of _____, 2020.

MAYOR

Published in the _____ on the ____ day of _____, 2020.

Posted on pcbgov.com on the ____ day of _____, 2020.

ITEM 5



CITY OF PANAMA CITY BEACH AGENDA ITEM SUMMARY

1. DEPARTMENT MAKING REQUEST/NAME:
CITY ATTORNEY / AMY MYERS

2. MEETING DATE:
JULY 23, 2020

3. REQUESTED MOTION/ACTION:

APPROVE RESOLUTION 20-138 APPROVING AN AGREEMENT WITH LYNNE FASONE TO SERVE AS THE CITY CLERK.

4. AGENDA

PRESENTATION
PUBLIC HEARING
CONSENT
REGULAR

5. IS THIS ITEM BUDGETED (IF APPLICABLE)? Yes No N/A
BUDGET AMENDMENT OR N/A

DETAILED BUDGET AMENDMENT ATTACHED Yes No N/A

6. BACKGROUND: (WHY IS THE ACTION NECESSARY, WHAT GOAL WILL BE ACHIEVED)

AT ITS JULY 9 MEETING, THE CITY COUNCIL INTERVIEWED AND VOTED ON THREE CANDIDATES TO BECOME THE CITY'S NEXT CITY CLERK. THE CITY COUNCIL RANKED EACH CANDIDATE AND SELECTED RUTH BOCCHINO AS THE FIRST SELECTION WITH LYNNE FASONE PLACING SECOND.

MS. BOCCHINO ELECTED NOT TO PURSUE THE POSITION AND THE CITY ATTORNEY HAS SINCE NEGOTIATED AN AGREEMENT WITH LYNNE FASONE. MRS. FASONE IS CURRENTLY THE CITY CLERK FOR THE CITY OF HILLIARD, OHIO AND HAS SERVED IN THAT POSITION FOR 15 YEARS. SHE RECEIVED HER MASTER MUNICIPAL CLERK CERTIFICATE IN 2014. IF APPROVED, MRS. FASONE WILL BEGIN HER EMPLOYMENT ON SEPTEMBER 8, 2020.

RESOLUTION 20-138

A RESOLUTION OF THE CITY OF PANAMA CITY BEACH, FLORIDA, APPROVING THE RECOMMENDATION OF LYNNE FASONE AS CITY CLERK AND THE AGREEMENT FOR AN ANNUAL SALARY OF \$82,000.

BE IT RESOLVED that the appropriate officers of the City approves the recommendation of Lynne Fasone as City Clerk and approves and to the extent necessary ratifies the City Clerk Employment Agreement, between the City and Lynne Fasone, relating to the terms and conditions of her employment as City Clerk, providing for an annual salary of Eighty Two Thousand Dollars (\$82,000.00) together with benefits as more particularly described in the body of the Agreement, in substantially the form attached and presented to the Council today, with such changes, insertions or omissions as may be approved by the City Manager, whose execution of such agreement shall be conclusive evidence of such approval.

THIS RESOLUTION shall be effective immediately upon passage.

PASSED in regular session this ___ day of _____, 2020.

CITY OF PANAMA CITY BEACH

By: _____
Mark Sheldon, Mayor

ATTEST:

Jo Smith, Interim City Clerk

EMPLOYMENT AGREEMENT

THIS EMPLOYMENT AGREEMENT (hereinafter referred to as "Agreement"), is by and between the City of Panama City Beach, Florida, a Florida municipal corporation (the "City") and Lynne Fasone (sometimes "Lynne Fasone" or the "City Clerk").

W I T N E S S E T H:

WHEREAS, the City desires to employ Lynne Fasone as City Clerk of the City, as provided for in Article 3 of the City's Charter; and

WHEREAS, the City, through its City Council, desires to provide for certain benefits and compensation for the City Clerk and to establish conditions of employment applicable to the City Clerk; and

WHEREAS, Lynne Fasone desires to accept employment as City Clerk of the City under the terms and conditions set forth herein.

NOW, THEREFORE, in consideration of the mutual promises and benefits set forth in this Agreement, the parties agree as follows:

Section 1. Employment.

A. The City hereby hires and appoints Lynne Fasone as its City Clerk, under the terms established herein, to perform the duties and functions specified in the City's Charter and the City Code of Ordinances and to perform such other legally permissible and proper duties and functions as the City Council shall from time to time assign.

B. The City's employment of Lynne Fasone as City Clerk shall become effective September 8, 2020. This Agreement shall remain in effect until terminated by the City or by the City Clerk as provided herein.

Section 2. Salary and Evaluation.

A. For the performance of services pursuant to this Agreement, the City agrees to pay the City Clerk an annual salary of \$82,000, payable in installments at the same time as other City employees are paid.

B. After the first year of the contract, should the general staff receive a cost of living increase, the City Clerk will receive the same increase at the same time as the other staff.

C. The City may also wish to increase said base salary or other benefits, or both, of the City Clerk in such amounts and to such an extent as the City Council may determine desirable on the basis of an annual performance evaluation of the City Clerk. Such evaluation shall be in such form as the Council deems appropriate and shall be made in October of each year in which this Agreement is effective.



D. Following the annual evaluation process the City Attorney shall provide the City Clerk with a written summary statement of the Council's findings, comments, and proposed new objectives. Thereafter, the City Clerk shall be provided the opportunity to discuss the evaluation with the Council.

E. Nothing in this Section shall require the City to increase the base salary or other benefits of the City Clerk. Furthermore, the City's failure to conduct any of the scheduled evaluations shall not constitute non-compliance with a material provision of this Agreement.

Section 3. Duties and Obligations.

A. The City Clerk shall have the duties, responsibilities and powers of said office under the Charter and Ordinances of the City. The City Clerk agrees to perform all duties and responsibilities faithfully, industriously, and to the best of her ability and in a professional and competent manner.

B. The City Clerk shall remain in the exclusive employ of the City and shall devote all such time, attention, knowledge and skills necessary to faithfully perform her duties under this Agreement. She shall not serve or become employed by any other entity while this agreement is in effect. The City Clerk may, however, engage in educational and professional activities upon receipt of approval by the City Council, provided that such activities shall not interfere with her primary obligation to the City as its City Clerk. The City Clerk shall dedicate no less than an average of forty (40) hours per week in the performance of her duties hereunder.

C. In the event the City Clerk shall serve on any appointed boards or elected boards of any professional organization, or serve on any committees related to her professional activities, in the event any monies are paid, or gifts received, by the City Clerk related to such service, such money or property shall be paid over to or delivered to the City, unless otherwise provided by the City Council.

Section 4. Communications Equipment

The City shall provide the City Clerk with a city cell phone and pay the minimum monthly charge for service. The City Clerk shall pay any additional charges incurred due to personal use by reimbursing the City promptly.

Section 5. Dues and Subscriptions

The City agrees to pay the City Clerk's professional dues for membership in one Florida local government clerk's association, one national local government clerk's association, and such other professional dues and subscriptions on behalf of the City Clerk as may be approved in the City's annual budget (on a line item basis) or as authorized separately by the City Council.

Section 6. Professional Development



The City agrees to pay reasonable and customary travel and subsistence expenses for the City Clerk's travel to and attendance at least one annual, professional conference of Florida local government clerks or national government clerks. The City may choose to pay for the City Clerk's attendance at other seminars, conferences, and committee meetings as it deems appropriate and approved by Council action.

Section 7. Community Involvement

The City recognizes the desirability of representation in and before local civic and other organizations and encourages the City Clerk to participate in these organizations to foster a continuing awareness of the City's activities as well as the community's attitudes and ideas.

Section 8. Vacation and Sick Leave

The City Clerk shall earn leave at a rate equivalent with department head with the ten (10) years of service. The City Clerk may not take leave greater than ten (10) consecutive working days without the consent of the City Council. Accrual and pay-out of accumulated leave shall be governed by the same policies as those that govern other City employees.

Section 9. Holidays

The City Clerk is entitled to the same paid holidays as the general City staff.

Section 10. Health, Dental, Life and Disability Insurance

The City agrees to provide, or make available, health insurance and other benefits to the City Clerk on the same terms and conditions as are established from time to time for all City employees generally.

Section 11. Retirement.

The City and the City Clerk agree that the City Clerk may participate in the General Employees' Retirement Fund under the terms and conditions as may from time to time be established for that Fund.

Section 12. Termination by the City and Severance Pay

A. The City Clerk shall serve at the pleasure of the City Council and shall not be a member of the City's Civil Service, and the City Council may terminate this Agreement and the City Clerk's employment with the City at any time, for any reason or for no reason.

B. Should a majority of the entire Council (three members) vote to terminate the services of the City Clerk "without cause", then within ten (10) business days following such vote, the Council shall cause the City Clerk to be paid any accrued and unpaid salary and benefits earned (including personal time off, holiday time and insurance but excluding such items and allowances



as are used in conducting City business such as, but not limited to, the use of the City computer and cell phone allowance) prior to the date of termination based on a forty (40) hour work week. Within forty-five (45) calendar days following the vote to terminate the City Clerk's employment, the Council shall cause the City Clerk to be paid a lump sum severance pay equal to eight (8) weeks of her salary as full and complete payment and satisfaction of any claims of the City Clerk of whatsoever nature arising out of this Agreement or otherwise. As consideration for such payment, the City Clerk shall, prior to receipt thereof, execute and deliver to the City a general release of the City and its Council members and its officers, agents, and employees for all acts and actions (whether accrued or subsequently accruing) from the beginning of time until the date of release, said release to be prepared by the City Attorney.

C. In the event the City Clerk is terminated for "just cause," the City shall have no obligation to pay the amounts outlined in Section 12, Paragraph B of this Agreement. For purposes of this Agreement, "just cause" is defined and limited for purposes of this Agreement to any of the following:

1. Misfeasance, malfeasance and/or nonfeasance in performance of the City Clerk's duties and responsibilities.
2. Conviction or a plea of guilty or no contest to a misdemeanor or felony crime, whether or not adjudication is withheld.
3. Neglect of duty, including the inability or unwillingness to properly discharge the responsibilities of office.
4. Violation of any substantive City policy, rule, or regulation, which would subject any other City employee to termination.
5. The commission or counsel of any fraudulent act against the interest of the City.
6. The commission or counsel of any act which involves moral turpitude, or which causes the City disrepute.
7. Violation of the International City/County Management Association Code of Ethics.
8. Any other act of a similar nature of the same or greater seriousness, including those listed in the definition of "Misconduct" contained in Section 443.036(29) Florida Statutes (2019).

Prior to the termination for just cause under this subparagraph, the City shall furnish to the City Clerk a written notification of the grounds for discharge. The City Clerk shall have the right to meet with the Mayor and City Attorney, with an advisor or counsel of her choosing to assist or represent her at that meeting, to rebut, refute or otherwise explain the charges of cause against her. If that meeting fails to resolve the matter, the City Clerk shall have the right to appear before the City Council with an advisor or counsel of her choosing to assist or represent her at that meeting,



to rebut, refute or otherwise explain the charges of cause against her. The City, acting through its City Council, shall then have the sole and absolute discretion to decide whether to terminate this agreement for cause and conclude the City Clerk's employment. Should a court of competent jurisdiction determine that just cause for termination did not exist, the City Clerk's termination shall be deemed conclusively to have been for convenience, without cause, and the City Clerk's sole remedy shall be receipt of severance pay as provided herein, plus interest at the annual rate provided for judgments computed from the day which is 45 days after the date of termination until the day payment is made.

D. In the event the Council, at any time during the employment term, reduces the salary or other benefits of the City Clerk, as identified herein, in a greater percentage than an equivalent across-the-board reduction for all full-time City employees, or in the event the City allegedly refuses to comply with any other material provision of this Agreement benefiting the City Clerk, the City Clerk shall notify the Council in writing of the alleged violation. The Council shall have forty-five (45) days from such notice within which to cure the violation, otherwise, the City Clerk may at her option, consider such violation as termination "without cause" as of the date of such alleged reduction or refusal, and the severance pay provision and other termination provisions contained herein shall become applicable at the annual salary and benefit level in effect prior to the reduction or refusal. This shall be the City Clerk's sole remedy in the event of a breach or other violation by the City of a material covenant in this agreement, the City Clerk acknowledging and agreeing that as an employee serving the public at the will and pleasure of the City Council pursuant to the Charter and laws governing the City, he has no property or liberty interest in her employment with the City beyond the eight week period of severance pay.

Section 13. Termination by the City Clerk

The City Clerk may terminate this Agreement at any time by delivering to the City Council a written notice of termination not later than ninety (90) days prior to the effective date of the termination. If the City Clerk terminates this Agreement, then the provisions of Section 12, Paragraph B above (severance pay), shall not apply. If the City Clerk voluntarily resigns pursuant to this Section, the City shall pay to the City Clerk all accrued compensation due the City Clerk up to the City Clerk's final day of employment, including any accrued personal time off. The City shall have no further financial obligation to Employee pursuant to this Agreement. This subsection shall not prevent the City Clerk from collecting any money earned as a result of participation in the City's retirement program.

Section 14. Disability

If the City Clerk becomes permanently disabled or is otherwise unable to perform her duties because of sickness, accident, injury, mental incapacity or health (but excluding death), for a period of four consecutive weeks beyond any accrued leave, the City shall have the option to terminate this Agreement, subject to the severance pay provision outlined in Section 12, Paragraph B of this Agreement.

Section 15. Relocation and Moving Expenses



A. The City Clerk shall be reimbursed for moving expenses to relocate herself and her family. Moving expenses shall be limited to the cost of packing, unpacking, insurance, storage, and moving the household goods and personal effects of the City Clerk from her place of residence to the City. Excluding for reimbursement as provided in subsection B, reimbursement shall be made upon the City Clerk's production of documents establishing that the services were provided by the lowest of (3) estimates and the production of receipts to document the expenditure. Reimbursement for relocation moving expenses shall not exceed \$10,000.00.

B. Vehicle mileage related to the City Clerk's relocation shall be reimbursed at the Internal Revenue Service Standard Mileage Rate for business travel. Meal reimbursement for meals incurred during travel shall be limited to \$80 per day. Lodging during relocation shall be reimbursed based upon receipts to document the expenditure.

C. The City agrees to pay the City Clerk up to Two Thousand, Five Hundred Dollars (\$2,500) per month for a period of three (3) months to reimburse her for the costs of relocating herself and her family to a new residence in Florida, to cover or be applied to the cost of temporary lodging. The City Clerk shall be reimbursed only when she can produce receipts to document the expenditure.

D. Should the City Clerk voluntarily terminate this Agreement within two years of her employment with the City, she will reimburse the City a prorated share of any expenses paid under this section based on the number of months remaining in the twenty-four month period. A pro-rate share of the total relocation expenses paid by the City will be returned to the City that equals the percentage of months remaining in the first twenty-four months commencing from the first date of employment. By way of illustration, if the City Clerk resigns 12 months after her first date of employment, the City Clerk shall reimburse the City fifty percent (50%) of the total expenses reimbursed under this section 15. Reimbursement under this subsection (D) shall not apply if the City Clerk's termination of this agreement is due to death or permanent disability.

Section 16. Indemnification.

A. City shall defend, save harmless, and indemnify the City Clerk against any action for any injury or damage suffered as a result of any act, event, or omission of action that the City Clerk reasonably believes to be in the scope of her duties or function, unless she acted in bad faith or with malicious purpose or in a manner exhibiting wanton and willful disregard of human rights, safety, or property. The City will compromise and settle any such claim or suit and pay the amount of any settlement or judgment rendered thereon. The City shall not be liable for the acts or omissions of the City Clerk committed while acting outside the course and scope of her agreed duties or committed in bad faith or with malicious purpose or in a manner exhibiting wanton and willful disregard of human rights, safety, or property. In such instance, the City Clerk shall reimburse the City for any legal fees and expenses the City has incurred or otherwise paid, for or on her behalf, in connection with the charged conduct.

B. Said indemnification shall survive the termination of employment and the termination or expiration of this Agreement to provide protection for any such acts undertaken or



committed in the City Clerk's capacity as a City employee, regardless of whether the notice of claim or filing of a lawsuit occurs during or following employment with the City.

Section 17. Bonding

The City agrees to bear the full cost of any fidelity or other bonds required of the City Clerk under any policy, regulation, ordinance or law.

Section 18. Code of Ethics

The "Code of Ethics" promulgated by the Florida Association of City Clerks is incorporated herein, and by this reference made a part hereof. Said "Code of Ethics" shall furnish principles to guide the City Clerk's duties, responsibilities, conduct and actions as City Clerk of the City.

Section 19. Attorney's Fees

If any litigation is commenced between the parties concerning any provision of this Agreement or the rights and duties of any person in relation thereto, the party prevailing in such litigation will be entitled, in addition to such other relief as may be granted, to reasonable attorney's fees and expenses incurred in connection therewith, including appellate fees and expenses.

Section 20. General Terms and Conditions

A. If any provision, or any portion thereof, contained in this Agreement is held by a court of competent jurisdiction to be unconstitutional, illegal, invalid or unenforceable, the remainder of this Agreement, or portion thereof, shall not be affected and shall remain in full force and effect.

B. The waiver by either party of a breach of any provision of this Agreement, or the failure to demand strict compliance with any provision, shall not operate or be construed as a waiver of any subsequent breach of the same or any other provision, or as a modification of the same or any other provision.

C. This Agreement is a personal agreement between the City and the City Clerk and may not be voluntarily assigned or involuntarily transferred.

D. This Agreement contains the entire Agreement of the parties. It may not be changed verbally, but only by an Agreement in writing signed by the parties.

E. Florida law shall govern this Agreement and any litigation that may arise from this Agreement, shall be filed and litigated in the 14th Judicial Circuit, in and for Bay County, Florida.

F. Upon City Clerk's death, the City's obligations under this Agreement shall terminate except for the following which shall be for the benefit of the City Clerk's personal representative or heirs:



1. Transfer of ownership of retirement funds, if any, to her designated beneficiaries;
2. Payment of accrued leave balances in accordance with this Agreement;
3. Payment of all outstanding hospitalization, medical and dental bills in accordance with City's insurance policies or plans; and
4. Payment of all life insurance benefits in accordance with the City's insurance policies or plans.

G. The parties acknowledge that each has shared equally in the drafting and preparation of this Agreement and, accordingly, no court construing this Agreement shall construe it more strictly against one party than the other by reason of authorship, and every covenant, term and provision of this Agreement shall be construed simply according to its fair meaning.

H. This Agreement may be executed in duplicate counterparts, each of which shall be deemed an original and all of which together shall be deemed one and the same instrument. No term, condition or covenant of this Agreement shall be binding on either party until both parties have signed it.

I. The effective date of this Agreement shall be the last date it is executed by either of the parties to this Agreement.



[Remainder of page intentionally blank.]

Executed by the CITY this _____ day of _____, 2020.

CITY OF PANAMA CITY BEACH

By: _____
Mark Sheldon,
Mayor

By: _____
Tony O'Rourke,
City Manager

ATTEST:

Jo Smith, Interim City Clerk

APPROVED AS TO LEGALITY AND FORM:

Amy Myers, City Attorney

Executed by the CITY CLERK this 19th day of July, 2020.

Witnesses:

Signature

DAVID BICKHAM
Print Name

Lynne Fasone

Signature

Gina Rhorick
Print Name

CITY OF PANAMA CITY BEACH
Job Description



JOB TITLE: City Clerk/Civil Service Administrator

SALARY RANGE: \$23.93 - \$39.49
SHIFT: Days
LOCATION: City Hall
REPORTS TO: City Council
PREPARED BY: City Manager
APPROVED BY: City Council

PAY GRADE: 38
DIVISION: Administration
DEPT: Administration
FSLA STATUS: Exempt
POSITION: Permanent Full-Time
DATE:

SUMMARY:

This position is responsible for complex administrative work to oversee the city's record management program and maintain all municipal official records; provide human resource, risk management and contract management support; clerical work in assisting the Civil Service Board; and other duties as assigned. Work is performed under the supervision of City Council and City Manager.

ESSENTIAL DUTIES AND RESPONSIBILITIES:

In addition to the essential duties and responsibilities, other tasks may be assigned:

Serves as ex-officio Clerk of the City Council.

Serves as the official depository for the storage and maintenance of all ordinances, resolutions, motions and documents of the City Council.

Serves as the official custodian of the City seal and of all official records, documents and papers of the City.

Gives notice of City Council meetings as required by law. Will be present for all meetings of the City Council.

Will record the proceedings of the City Council electronically and in a journal which he/she shall maintain for such purpose.

Will establish regulations and procedures for making official city records available to the public.

Implement and maintain the Granicus agenda software system.

Oversees and coordinates responses for public records requests.

Provides administrative support to the City Manager, City Secretary, Civil Service, and Human Resources and Risk Director.

Performs such other duties as they City Council may require.

Civil Service:

Assists the Civil Service Board in maintaining all job applications and administers all examinations prescribed by Board.

Serves as the administrator for the NEOGOV hiring system.

Prepare backup materials for Board meetings; takes notes and records all Board meetings in order to type minutes for the Board's approval

Prepares for job interviews of prospective employees;

Handles daily correspondence; must keep varied clerical records.

Prepare reports and file office records.

Maintains hire dates and advises of end of probation periods.

Advises Human Resources for recognition of milestone dates.

Notifies Commissioners of meetings and maintains minutes for them.

Advertise for positions as directed by City Manager. Posts vacancies as directed on the City website and posts notices to all Departments.

Type letters as instructed (signed by the Chairman when directed).

Coordinates drug testing for potential new employees.

Coordinates annual meeting of employees to include election of a new Commissioner - if more than one nominated, must handle the election.

Must be able to obtain Notary Public certificate within three months.

Will rotate duties on switchboard as relief for receptionist as needed.

Related duties as required.

SUPERVISORY RESPONSIBILITIES:

None



COMPETENCIES:

To perform the job successfully, an individual should demonstrate the following competencies:

Analytical - Synthesizes complex or diverse information; Collects and researches data; Uses intuition and experience to complement data; Designs work flows and procedures.

Problem Solving - Identifies and resolves problems in a timely manner; Gathers and analyzes information skillfully; Develops alternative solutions; Works well in group problem solving situations; Uses reason even when dealing with emotional topics.

Project Management – Develops project plans; coordinates projects; communicates changes and progress; completes projects on time and budget; manages project team activities.

Technical Skills - Assesses own strengths and weaknesses; Pursues training and development opportunities; Strives to continuously build knowledge and skills; Shares expertise with others.

Customer Service - Manages difficult or emotional customer situations; Responds promptly to customer needs; Solicits customer feedback to improve service; Responds to requests for service and assistance; Meets commitments.

Interpersonal Skills - Focuses on solving conflict, not blaming; Maintains confidentiality; Listens to others without interrupting; Keeps emotions under control; Remains open to others' ideas and tries new things.

Oral Communication - Speaks clearly and persuasively in positive or negative situations; listens and gets clarification; Responds well to questions; Demonstrates group presentation skills; Participates in meetings.

Written Communication - Writes clearly and informatively; Edits work for spelling and grammar; Varies writing style to meet needs; Presents numerical data effectively; Able to read and interpret written information.

Teamwork - Balances team and individual responsibilities; Exhibits objectivity and openness to others' views; Gives and welcomes feedback; Contributes to building a positive team spirit; Puts success of team above own interests; Able to build morale and group commitments to goals and objectives; Supports everyone's efforts to succeed.

Visionary Leadership – Displays passion and optimism; inspires respect and trust; mobilizes others to fulfill the vision; provides vision and inspiration to peers and subordinates.

Change Management – Develops workable implementation plans; communicates

changes effectively; builds commitment and overcomes resistance; prepares and supports those affected by change; monitors transition and evaluates results.

Delegation – Delegates work assignments; matches the responsibility to the person; gives authority to work independently; sets expectations and monitors delegated activities; provides recognition for results.

Leadership - Exhibits confidence in self and others; Inspires and motivates others to perform well; effectively influences actions and opinions of others; Accepts feedback from others; Gives appropriate recognition to others.

Managing People – Includes staff in planning, decision-making, facilitating and process improvement; takes responsibility for subordinates activities; makes self available to staff; provides regular performance feedback; develops subordinates' skills and encourages growth; solicits and applies customer feedback (internal and external); fosters quality focus in others; improves processes, products and services; continually works to improve supervisory skills.

Quality Management – Looks for ways to improve and promote quality; demonstrates accuracy and thoroughness.

Diversity - Demonstrates knowledge of EEO policy; Shows respect and sensitivity for cultural differences; educate others on the value of diversity; promotes a harassment-free environment; Builds a diverse work force.

Ethics - Treats people with respect; Keeps commitments; inspires the trust of others; Works with integrity and ethically; Upholds organizational values.

Organizational Support - Follows policies and procedures; Completes administrative tasks correctly and on time; supports organization's goals and values; Benefits organization through outside activities; Supports affirmative action and respects diversity.

Strategic Thinking – Develops strategies to achieve organizational goals; understands organization's strengths and weaknesses; analyzes market and competition; identifies external threats and opportunities; adapts strategy to changing conditions.

Judgement - Displays willingness to make decisions; Exhibits sound and accurate judgment; Supports and explains reasoning for decisions; Includes appropriate people in decision-making process; Makes timely decisions.

Motivation - Sets and achieves challenging goals; Demonstrates persistence and overcomes obstacles; Measures self against standard of excellence; Takes calculated risks to accomplish goals.



Planning/Organizing – Prioritize and plans work activities; uses time efficiently; plans for additional resources; sets goals and objectives; organizes or schedules other people and their tasks; develops realistic action plans.

Professionalism - Approaches others in a tactful manner; Reacts well under pressure; Treats others with respect and consideration regardless of their status or position; Accepts responsibility for own actions; Follows through on commitments.

Quality - Demonstrates accuracy and thoroughness; Looks for ways to improve and promote quality; Applies feedback to improve performance; Monitors own work to ensure quality.

Quantity - Meets productivity standards; Completes work in timely manner; Strives to increase productivity; Works quickly.

Safety and Security - Observes safety and security procedures; Determines appropriate action beyond guidelines; Reports potentially unsafe conditions; Uses equipment and materials properly.

Adaptability - Adapts to changes in the work environment; Manages competing demands; Changes approach or method to best fit the situation; Able to deal with frequent change, delays, or unexpected events.

Attendance/Punctuality - Is consistently at work and on time; Ensures work responsibilities are covered when absent; Arrives at meetings and appointments on time.

Dependability - Follows instructions, responds to management direction; Takes responsibility for own actions; Keeps commitments; Commits to long hours of work when necessary to reach goals. Completes tasks on time or notifies appropriate person with an alternate plan.

Initiative - Volunteers readily; Undertakes self-development activities; Seeks increased responsibilities; Takes independent actions and calculated risks; Looks for and takes advantage of opportunities; Asks for and offers help when needed.

Innovation - Displays original thinking and creativity; Meets challenges with resourcefulness; Generates suggestions for improving work; Develops innovative approaches and ideas; Presents ideas and information in a manner that gets others' attention.

QUALIFICATION REQUIREMENTS:

To perform this job successfully, an individual must be able to perform each essential duty satisfactorily. The requirements listed below are representative of the knowledge, skill, and/or ability required. Reasonable accommodations may be made to enable

individuals with disabilities to perform the essential functions.

EDUCATION and EXPERIENCE:

The best candidates will have seven (7) to nine (9) years progressively responsible administrative support experience.

Knowledge of pertinent federal, state and local ordinances, codes, and regulations related to public records and records management is important. Specific knowledge of Florida law is a plus but by no means required.

Professional certifications, such as a Certified Municipal Clerk (CMC) or Master Municipal Clerk (MMC) are highly desirable.

LANGUAGE SKILLS:

Ability to read and interpret documents. Ability to speak English effectively before groups, as well as one on one. Must remain courteous and professional at all times.

MATHEMATICAL SKILLS:

Ability to add, subtract, multiply, and divide in all units of measure, using whole numbers, common fractions, and decimals. Ability to compute rate, ratio, and percent and to draw and interpret bar graphs.

REASONING ABILITY:

Ability to solve practical problems and deal with a variety of concrete variables in situations where only limited standardization exists. Ability to interpret a variety of instructions furnished in written, oral, diagram, or schedule form.

OTHER REQUIREMENTS:

Must have knowledge of standard office and clerical practices and procedures, as well as knowledge and proficiency in the use of standard office machines, computers (Microsoft Office applications specifically) and calculators. Must have knowledge of the legal documents utilized in municipal government and the procedures necessary to process them; must have comprehensive knowledge of the mechanics and functions of City Government and extensive knowledge of the City Charter.

Must possess valid Florida Driver's License - driving record must be acceptable to the City insurance program. Applicants will be administered applicable tests and typing test.

Must be able to establish and maintain good working relationship with City officials, department heads, other City employees and the general public; must be able to perform illustrative duties and essential eligibility tasks in a manner which is not a direct threat or significant risk to the health or safety of others that cannot be eliminated by a modification of policies, practices or procedures of the City, or by provision of auxiliary aids. "Direct threat" shall be determined pursuant to 28 CFR, Section 36.208.

PHYSICAL DEMANDS:

The physical demands described here are representative of those that must be met by an employee to successfully perform the essential functions of this job. Reasonable accommodations may be made to enable individuals with disabilities to perform the essential functions.

While performing the duties of this job, the employee is regularly required to sit, stand, walk, talk or hear, use hands to finger, handle or feel, stoop, kneel, crouch or crawl, and reach with hands and arms.

The employee may occasionally lift and move up to 25 pounds. Specific vision abilities required by this job is ability to adjust focus, close vision and peripheral vision, color vision and distance vision. Some specific job duties that require one or more of the physical demands mentioned are typing, filing, moving boxes, typewriters, and tables.

WORK ENVIRONMENT:

The work environment characteristics described here are representative of those an employee encounters while performing the essential functions of this job. Reasonable accommodations may be made to enable individuals with disabilities to perform the essential functions.

While performing the duties of this job, the employee is not subjected to any special or extraordinary environmental conditions, other than those normally found in an office environment. The noise level in the work environment is usually quiet to moderate.

I hereby acknowledge receipt of the job description and certify that I meet the qualification requirements stated herein and I am able to perform the essential duties and responsibilities of this position. I acknowledge that in addition to the duties outlined above I may be required to perform additional duties.

Lynne M. Fasone
Signature

07/19/2020
Date

ITEM 6



CITY OF PANAMA CITY BEACH AGENDA ITEM SUMMARY

1. DEPARTMENT MAKING REQUEST/NAME:

Panama City Beach Police Department

2. MEETING DATE:

July 23, 2020

3. REQUESTED MOTION/ACTION:

We respectfully request the Council's approval for the purchase of one (1) new Ford Explorer Vehicle to replace a previous Police Fleet vehicle that was totaled.

4. AGENDA

PRESENTATION
PUBLIC HEARING
CONSENT
REGULAR

5. IS THIS ITEM BUDGETED (IF APPLICABLE)? YES NO N/A
BUDGET AMENDMENT OR N/A

DETAILED BUDGET AMENDMENT ATTACHED YES NO N/A

6. BACKGROUND: (WHY IS THE ACTION NECESSARY, WHAT GOAL WILL BE ACHIEVED)

We respectfully request the Council's approval to purchase one (1) Explorer Police Interceptor at a cost of \$33,315.00 from Garber Fleet Sales. This purchase will allow for the replacement of a totaled vehicle as a result of a motor vehicle traffic crash. This purchase amount is agreed from a previous awarded bid.

The totaled vehicle has been retained by the insurance company and compensated the value to us totalling \$24,153.00

This leaves a total offsetting cost of \$9,162.00 which is currently available in this year's budget.

Clayton Jordan

From: Sonllaliz Trujillo <strujillo@flcities.com>
Sent: Tuesday, April 14, 2020 9:22 AM
To: Clayton Jordan
Cc: Lori Philput
Subject: RE: Claim VA2020097203 - DOL 3/16/20 - Member's Vehicle 2017 Ford Explorer VIN 3410

[CAUTION] This email originated from outside of the organization. Do not follow guidance, click links, or open attachments unless you recognize the sender and know the content is safe.

Good morning,

If the member decides to keep the vehicle for parts the following breakdown applies:

Value	\$24,153.00
Less Ded	\$ 500.00
Less Salvage Bid	\$ 7,566.00
Total Settlement	\$16,087.00

Sincerely,

Sonllaliz Trujillo
Claims Representative I
Florida League of Cities, Inc.
407-367-1824
www.flcities.com



**LOCAL
VOICES
MAKING
LOCAL
CHOICES**

From: Clayton Jordan <cjordan@beachpolice.org>
Sent: Tuesday, April 14, 2020 10:18 AM
To: Sonllaliz Trujillo <strujillo@flcities.com>
Cc: Lori Philput <lphilput@pcbgov.com>
Subject: RE: Claim VA2020097203 - DOL 3/16/20 - Member's Vehicle 2017 Ford Explorer VIN 3410

What would the value of the vehicle be for us to retain it for parts?

From: Sonllaliz Trujillo [<mailto:strujillo@flcities.com>]
Sent: Tuesday, April 14, 2020 8:54 AM
To: Lori Philput <lphilput@pcbgov.com>
Cc: Clayton Jordan <cjordan@beachpolice.org>; PL Mail <plmail@flcities.com>
Subject: Claim VA2020097203 - DOL 3/16/20 - Member's Vehicle 2017 Ford Explorer VIN 3410

[CAUTION] This email originated from outside of the organization. Do not follow guidance, click links, or open attachments unless you recognize the sender and know the content is safe.

Good morning Lori,

As per my voice message, serve this email to provide you with an update on the subject claim. We are in receipt of the inspection report and the member's vehicle has been deemed a total loss as the amount of repairs in comparison to the actual value of the vehicle surpassed the Florida state threshold.

The vehicle has been valued in the amount of \$24,153.00 less the \$500 Collision deductible the total loss settlement is \$23,653.00. Also, the member has the option to retain the vehicle. If that is the case the total settlement will be reduced by \$7,566.00 which is the highest bid quote for a new total settlement of \$16,087.00.

Attached please find the valuation report for your review.

In the event the member decides for the Florida League of Cities to pick up the vehicle, we will need the original title for the vehicle, **which needs to be signed on the front lower left-hand corner where it is printed Signature of Seller or Seller Signature. Please include "Letter of Authorization" on the City's letter head along with title. The person signing the letter of authorization cannot sign the title. Must be a different individual. Be sure to sign the letter in black or blue ink. Please note: An electronic signature will not be accepted (an example has been attached to this email). The license plate and any personal belongings will need to be removed from the vehicle before CoPart pick up the vehicle.**

If you have any further questions regarding the valuation report please can contact Mr. Oscar Pineda with CCS at 832-755-0228.

Looking forward to hear from you regarding member's decision.

Best Regards,

Sonllaliz Trujillo
Claims Representative I
Florida League of Cities, Inc.
407-367-1824
www.flcities.com



RESOLUTION 20-139

A RESOLUTION OF THE CITY OF PANAMA CITY BEACH, FLORIDA, APPROVING THE PURCHASE OF A FORD EXPLORER FROM GARBER FLEET SALES IN THE AMOUNT OF \$33,315.00.

BE IT RESOLVED that the appropriate officers of the City are authorized to accept and deliver on behalf of the City that certain Agreement between the City and Garber Fleet Sales, relating to the purchase of a replacement Ford Explorer for the Police Department, in the basic amount of Thirty Three Thousand, Three Hundred Fifteen Dollars (\$33,315.00), in substantially the terms of the quote attached and presented to the Council today, dated October 13, 2019..

THIS RESOLUTION shall be effective immediately upon passage.

PASSED in regular session this ___ day of _____, 2020.

CITY OF PANAMA CITY BEACH

By: _____
Mark Sheldon, Mayor

ATTEST:

Jo Smith, Interim City Clerk



Panama City Beach Police Department

Specification #	239
Unit Description	KBA

Prepared for: **10/13/2019** Prepared by: **Garber Ford, Inc.**

10/13/2019
 Panama City Beach Police Department
 Attn: Wayne Maddox
wmaddox@beachpolice.org
 (850) 233-5000

Garber Ford, Inc.
 Ryan Davis
 (904) 264-2442 ext.2350 FAX: (904) 284-0054
 3380 Hwy 17 Green Cove Springs, FL 32043
rdavis@garberautotmall.com

Florida Sheriffs Association

Prices are published by the Florida Sheriffs Association.
 (https://www.fsheriffs.org/four_program/purchasing_programs/cooperative-fleet-bid-awards/). Purchasing contract number is FSA19-VEL 27.0, expiring September 30th, 2020 for - Police Rated Vehicles/Motorcycles, Sedans & Light Trucks. If you have any questions regarding this quote please call!

		Base Price	
KBA	2020 Ford Police Interceptor Utility AWD	\$35,278.00	
Codes	Optional Equipment	Unit Price	Net Price
500A	Order Code 500A	Included	\$0.00
99W	Engine: 3.3L V6 Direct-Injection Hybrid System	Included	\$0.00
44B	Transmission: 10-Speed Automatic	Included	\$0.00
YZ	Oxford White	Included	\$0.00
96	Charcoal Black, Unique HD Cloth Front Bucket Seats w/Vinyl Rear	Included	\$0.00
153	Front License Plate Bracket	Included	\$0.00
51P	Left Hand Spotlight - LED	Included	\$0.00
86T	Tail Lamp/Police Interceptor Housing Only	59	\$59.00
17A	Auxiliary Air Conditioning	609	\$609.00
43D	Dark Car Feature	24	\$24.00
55F	Remote Keyless Entry Key Fob w/o Key Pad	339	\$339.00
TTAG	Temporary Tag	6	\$6.00
OPTION	*Gas Engine Deduct* 99B - Engine: 3.3L V6 Direct-Injection (FFV)	(\$3,000.00)	
OPTION	*Turbo Engine Upgrade* 99C - Engine: 3.0L V6 EcoBoost	\$789.00	
TOTAL PURCHASE AMOUNT: 99W Hybrid			\$ 36,315.00 x11 = \$399,465.00
TOTAL PURCHASE AMOUNT: 99B Gas Engine			\$ 33,315.00 x11 = \$366,465.00
TOTAL PURCHASE AMOUNT: 99C EcoBoost			\$ 37,104.00 x11 = \$408,144.00

Notice to Bid - Police Fleet Vehicles

Category: Admin
RFP Number: 101519.Police Fleet Vehicles
Start Date: 09/27/2019 4:09 PM
Close Date: 10/15/2019 11:00 AM

NOTICE TO RECEIVE SEALED BIDS

Panama City Beach Police Department – Police Fleet Vehicles

The City of Panama City Beach hereby solicits closed bids for the following equipment:

(11) Eleven -- 2020 Ford Interceptor Utility AWD.

PLEASE SEE SPECIFICATIONS LISTED BELOW FOR EACH VEHICLE CATEGORY

The Bids should include ALL fees, including delivery charges (if any).

Bids must be sealed and will be received until 11:00 a.m. Central Time, October 15, 2019 at the City of Panama City Beach City Hall, Attn: Captain Wayne Maddox, 17115 Panama City Beach Parkway, Panama City Beach, Florida, 32413 and will be opened and read publicly immediately thereafter.

The City reserves the right to reject any and all bids and to waive any formality in bids received. All bidders shall comply with all applicable State and local laws concerning licensing, registration, and regulations of businesses in the State of Florida.

All bids shall be firm and for a period of 6 months after opening

Specifications needed for Ford Interceptor Utility AWD:

K8A 2020 Ford Interceptor Utility AWD PRICE \$33,965.00 EACH
YZ - Oxford White
153 - Front License Plate Bracket
51P - Driver LED Spot Light
86T - Tail Lamp/Police Interceptor Housing Only
17A - Auxiliary Air Conditioning
43D - Dark Car Feature
55F - Remote Keyless Entry
99B 3.3L V-6 ENGDIRECT INJECTION

BOZARD FORD CO
540 OYULET MALL BLVD
ST AUGUSTINE FLA 32084

JOSEPH WINDROW

ITEM 7



CITY OF PANAMA CITY BEACH AGENDA ITEM SUMMARY

1. DEPARTMENT MAKING REQUEST/NAME:

Panama City Beach Police Department

2. MEETING DATE:

July 23, 2020

3. REQUESTED MOTION/ACTION:

We respectfully request the Council's approval to issue a request for proposal for Police Body Worn Cameras.

4. AGENDA

- PRESENTATION
- PUBLIC HEARING
- CONSENT
- REGULAR

5. IS THIS ITEM BUDGETED (IF APPLICABLE)? Yes No

N/A

BUDGET AMENDMENT OR N/A

DETAILED BUDGET AMENDMENT ATTACHED Yes No

N/A

6. BACKGROUND: (WHY IS THE ACTION NECESSARY, WHAT GOAL WILL BE ACHIEVED)

We respectfully request the Council's approval to issue a request for proposal for Police Body Worn Cameras. These cameras are much needed in law enforcement today and will assist us in a multitude of ways.

01. Prosecuting cases will become easier as the actual occurrence will be on video thus allowing for better case preparation.

02. Cameras will assist when dealing with complaints. The University of Nevada has summarized a significant reduction in complaints of police misconduct and police use of force incidents when cameras are worn (UNLV Study 2017). The study also found a considerable cost savings for police by simplifying the complaint resolution process.

03. Cameras will help protect the police and the public alike. People tend to behave better when they are on video in general, thus making public contacts safer for all.

**NOTICE
CITY OF PANAMA CITY BEACH
REQUEST FOR PROPOSALS**

"Body Worn Cameras"

The City of Panama City Beach (the "City") hereby gives notice that it has issued a Request for Proposals from experienced and qualified persons or firms for providing pricing of body worn cameras. Interested Firms are asked to carefully consider the City's expectations of qualifications as stated in the RFP Instructions.

Sealed proposals will be received by the City Manager at City Hall located at 17007 Panama City Beach Parkway, Panama City Beach, FL 32413 until 10:00 a.m. (CST), Date TBD. Submittals will be publicly opened and receipt acknowledged immediately thereafter. The qualifications and other information should be submitted in strict compliance with the directives provided in the RFP Instructions. The City is under no obligation: either express or implied, to reimburse responding firms for any expenses associated with preparation and submittal of the Proposals in response to this request.

Proposals shall be submitted in a sealed envelope or box, plainly marked with respondent's name, address, date, time of RFP deadline and stating "Proposal for Body Worn Cameras." Eight (8) hard copies, and one digital copy, shall be submitted.

RFP Instructions are available to prospective Firms at the City Police Department, 17115 Panama City Beach Parkway, Panama City Beach, FL 32413. Inquiries regarding this RFP should be directed to Captain Wayne Maddox, by email wmaddox@beachpolice.org or telephone 850.233.5000.

The City reserves the right to accept or reject any and all Proposals in whole or in part, to waive informalities in the RFP documents, to obtain new Proposals, or to postpone the opening of Proposals, or if unable to negotiate a satisfactory contract to terminate all negotiations under the RFP and proceed by whatever appropriate means it may elect. Each Proposal shall be valid to the City for a period of six months (180 days) after opening.

The City of Panama City Beach is an Equal Opportunity Employer.

**CITY OF PANAMA CITY BEACH
REQUEST FOR PROPOSALS**

BODY WORN CMAERAS

The City Council of the City of Panama City Beach is requesting proposals from experienced and qualified person or firms for providing pricing of body worn cameras. The City envisions a proposer who will provide a quality product and ensure technical support and training is provided.

SCOPE and CLASSIFICATION

Scope: The City of Panama City Beach, is seeking request for proposals (RFPs) to provide the City Police Department with a contract for a commercially available body worn camera (BWC) solution for the use of the Panama City Beach Police Department. This is to include the body worn cameras, associated peripherals and accessories, storage solution, training and warranties during the term of the contract. The City is seeking proposals from responsible bidders capable of providing the needed equipment. The City expects to purchase approximately 60+ BWCs as a result of this process. The City will negotiate a term with the selected bidder for up to five (5) years.

Classification: Bidders are encouraged to submit proposals that demonstrate their competence, ability, past performance, quality and feasibility, and cost, as defined in this request. The City may contract with one or more bidders chosen through this RFP process.

SPECIFICATIONS

General Information:

Term: The City anticipates signing a three (3) to five (5) year agreement.

Quantity Estimate: The City anticipates purchasing 60+ BWCs in 2020. Any estimate made in this document or by any other representative of the City is not to be construed as representing an actual order(s) or a guarantee that any minimum amount will actually be purchased.

Universal Term Contract: This proposal is bidders offer to sell the item(s) set forth in its proposal. Bidder is to take notice that the City make no warranties or representations that the estimated quantity, or any quantity at all, will be ordered by the City even though bidders proposal is accepted by the City and a firm offer for sale executed. If bidders proposal is accepted by the City and the firm offer for sale executed, the bidder is to take further notice that no act, or order placed by the City or by any official, employee or agent of the City shall constitute an order or contractually bind the City, without the proper certificate that funds sufficient for full payment due on any order are available. Each order placed under the firm offer for sale shall require execution of a purchase order. Said bidder shall offer to sell buyer, City of Panama City Beach, who shall have the contract term to exercise this option to purchase, at the price and on the terms set forth in the negotiated agreement arising from this proposal. The City shall not be precluded from buying similar items from other suppliers, or the same items in the event of an emergency. In the event of an overlap in the annual term of subsequent universal term contracts, The City may purchase the desired item from either awarded contract at the City's sole discretion.

RFP Overview: The bidders response to this RFP should be a clear and concise description of the bidders capabilities and proposed offerings. The RFP will be evaluated using (1) the competence of the bidder to perform under the contract as indicated by the technical training, education, and experience of the bidders personnel who would be assigned to perform the work; (2) the quality and feasibility of the bidders technical proposal; (3) the ability of the bidder to perform under the contract competently and expeditiously as indicated by the bidders workload and the availability of necessary personnel, equipment, and facilities; and (4) past performance of the bidder as reflected by evaluations of the city agencies, other city agencies, and other previous clients of the bidder with respect to such factors as quality of work, success in controlling costs, and success in meeting deadlines. Each of these factors is to be responded to in the manner described herein.

TECHNICAL SPECIFICATIONS

Scope: It is the intent of these specifications to describe BWC's in sufficient detail to secure proposals. Bidders should address each subsection in their proposal. In all instances, the bidder is to clearly indicate how the proposed solution meets the desire of the City of Panama City Beach for a commercially available BWC full solution. The bidder shall include as appropriate explanation of the type of equipment offered in detail, and with full supporting data to ensure that

the City can properly evaluate the proposal.

All parts not mentioned, which are necessary to provide a complete commercially available BWC solution, shall be included in the offer and shall conform in strength and quality of workmanship to what is usually provided to the trade in general.

The proposal should not include components, or finished units that are of a prototype nature, or have not been in production for a sufficient period of time to prove their performance capabilities.

Bidders shall submit with their proposal detailed specifications for hardware, physical environment, redaction software, and infrastructure needs which clearly show all of the necessary components of the commercially available BWC solution being offered. Bidders may submit with their proposals descriptive literature, brochures, etc.

VENDOR SPECIFICATIONS

Vendor company information

Please provide with your proposal detailed information on your company's services and capabilities, background and history (including acquisitions, bankruptcies, and reorganizations) management and key personnel bios.

Technical Support:

The selected Bidder must have technical support services available. The City prefers this support be on a toll-free basis, 24 hours a day, 7 days a week, during the entire contract period with a 1/2 hour (30 minutes) or less response time to problems, with a clearly defined priority escalation process. The selected Bidder shall also provide on-site technical support when required. This on-site support may be requested when it is determined the problem cannot be corrected by telephone support. Bidders shall include description in the proposal response outlining the support services offered and any limitations thereof.

The City strongly prefers that the awarded vendor must provide experts to testify in court to the functionality and limitations of the system as the need arises during the term of the contract.

VENDOR HOSTED (CLOUD) STORAGE PROPOSALS, IF APPLICABLE

With any vendor hosted solution, the Panama City Beach Police Department will retain sole ownership of all the records and recordings. The use of dissemination of any record or recording by the selected Bidder or anyone affiliated with the Bidder, is strictly prohibited, without the written consent of the Panama City Beach Police Department.

TRAINING

Operations: The City prefers that the Bidder provides the Department with a "train-the-trainer" level course and instruction. These officers/individuals shall be provided with sufficient training materials and equipment for all officer and administrative trainings scheduled for the life of the contract so to remain current with any hardware and software updates. If a "train-the-trainer" training program is not available, please provide a description of training solutions offered by your organization.

Advanced/IT Support Training: The Bidder shall provide an advanced training course for a recommended number of students consistent with the size of the proposed BWC program. The training should at minimum, focus on the areas related to the BWC system operation; use of equipment, maintenance, troubleshooting, assigning equipment, change-out of components in need of repair, account management, video management, and video security, to remain current with hardware and software updates.

Stakeholder Access Training: Describe the available training options for additional agencies, such as the City/County Attorney's Office, which will require access to stored audio/video.

WARRANTIES

The equipment specified herein shall be covered by a warranty. **Submit a copy of the warranty with the proposal.** The City strongly prefers warranty be directly from Bidder. Indicate in offer if warranties commence with the delivery date or the date of manufacturer. Include any information on a delayed warranty procedure to cover the interval between time of delivery of the complete solution and the actual date that the BWC is placed in service by the City. This delayed time period will cover camera, docks,

batteries, accessories, hardware and software, etc.

PANAMA CITY BEACH POLICE DEPARTMENT BODY CAMERA PROPOSAL FOR 2020

To be submitted in a sealed envelope or box, properly marked " BID FOR BODY WORN CAMERAS" to the City Manager of the City of Panama City Beach, Florida, 17007 Panama City Beach Parkway, Panama City Beach, FL 32413 before 10:00 A.M. (CST), on Date TBD. Outside of envelope not being properly marked or received before the above date and time may result in bid being disqualified.

ITEM 8



CITY OF PANAMA CITY BEACH AGENDA ITEM SUMMARY

1. DEPARTMENT MAKING REQUEST/NAME:

Al Shortt, Utilities Director

2. MEETING DATE:

July 23, 2020

3. REQUESTED MOTION/ACTION:

Approve the attached Resolution 20-140, which adopts the amended City Cross Connection Control Program as required by the Florida Department of Environmental Protection

4. AGENDA

PRESENTATION
PUBLIC HEARING
CONSENT
REGULAR

5. IS THIS ITEM BUDGETED (IF APPLICABLE)? YES NO N/A
BUDGET AMENDMENT OR N/A

DETAILED BUDGET AMENDMENT ATTACHED YES NO N/A

6. BACKGROUND: (WHY IS THE ACTION NECESSARY, WHAT GOAL WILL BE ACHIEVED)

The Utilities Department has a Cross Connection Control Program that has been in effect since 1996. Its primary mission is to protect the City's water distribution system from contamination or pollution due to backflow of contaminants or pollutants via customer's water service connections. All utilities in the state are now being required by the Florida Department of Environmental Protection to amend their programs. The City's current program will be largely unaffected, except for a new provision requiring backflow prevention devices to be installed and tested on all metered residential accounts that use potable water.

The installation of these residential irrigation backflow prevention devices will be the responsibility of the account holder and staff expects each installation will cost from a low of \$250 to over \$1,000 depending on the individual circumstances. They will need to be certified by a Florida certified tester upon installation, and then every two years thereafter to verify they are functioning as required. Those costs are currently estimated to be between \$40 and \$100 per event.

Given the number of metered residential irrigation accounts in our system that use potable water, staff expects that it will take 24 months to fully implement the new requirements. This program change is being directed by FDEP and the City could be subjected to a punitive action from the Department for failure to comply.

Staff recommends approval of this mandatory program amendment.

RESOLUTION NO. 20-140

A RESOLUTION OF THE CITY OF PANAMA CITY BEACH, FLORIDA, APPROVING AMENDMENTS TO THE CITY'S CROSS-CONNECTION CONTROL PROGRAM.

WHEREAS, a community water system is responsible for supplying its customers with water that meets federal and State drinking water standards;

WHEREAS, a community water system is responsible for the protection of its water distribution system from contamination or pollution due to backflow of contaminants or pollutants through water service connections; and

WHEREAS, Rule 62-555.360, Florida Administrative Code, requires that each community water system shall establish and implement a cross-connection control program utilizing backflow protection at or for service connections in order to protect the community water system from contamination caused by cross-connections on customer's premises; and

WHEREAS, on May 10, 1994, the City adopted Ordinance 427, approving a Cross-Connection Control Program; and

WHEREAS, Ordinance 427 provided that the Cross-Connection Program may be amended by resolution of the City Council from time to time to protect the health and welfare of the residents; and

WHEREAS, the Council finds and determines that amendments to the City's Cross-Connection Program relating to residential irrigation backflow prevention are necessary to establish where backflow protection at or for service connections is mandatory, and the ownership, installation, testing and maintenance requirements for mandatory backflow prevention.

NOW, THEREFORE, BE IT RESOLVED by the City Council of the City of Panama City Beach, that from and after the effective date of this Resolution, the updated Cross-Connection Control Program for the City of Panama City Beach, dated July 15, 2020, attached and incorporated herein as Exhibit A, is hereby adopted to establish where backflow protection at or for service connections is mandatory and the requirements regarding ownership, installation, inspection/testing, and maintenance of mandatory backflow protection at or for service connections. The City's prior cross-connection control program dated April 12, 1994, shall be repealed, rescinded, superseded, and replaced by this resolution.

This resolution shall become effective immediately upon its passage. Officers and agents of the City shall not enforce any penalty against existing customers for violation of this program prior to July 24, 2022.

PASSED AND ADOPTED in regular session by the City of Panama City Beach on the _____ day of July, 2020.

CITY OF PANAMA CITY BEACH

By: _____
Mark Sheldon, Mayor

ATTEST:

Jo Smith, Interim City Clerk

**CITY OF PANAMA CITY BEACH,
FLORIDA**

**CROSS-CONNECTION CONTROL
PROGRAM**



REVISED JULY 2020

INTRODUCTION

The City of Panama City Beach Water Supply System, PWS 1030515, hereinafter referred to as the "community water system (CWS)," has the responsibility to protect itself from contamination caused by cross-connections on customers' premises. A cross-connection is defined in Rule 62-550.200, Florida Administrative Code (F.A.C.), as follows:

"CROSS-CONNECTION" means any physical arrangement whereby a public water supply is connected, directly or indirectly, with any other water supply system, sewer, drain, conduit, pool, storage reservoir, plumbing fixture, or other device which contains or may contain contaminated water, sewage or other waste, or liquid of unknown or unsafe quality which may be capable of imparting contamination to the public water supply as the result of backflow. By-pass arrangements, jumper connections, removable sections, swivel or changeable devices, and other temporary or permanent devices through which or because of which backflow could occur are considered to be cross-connections.

Pursuant to Rule 62-555.360, F.A.C., the CWS is required to establish and implement a cross-connection control (CCC) program utilizing backflow protection at or for service connections from the CWS. The CCC program must include a written plan that contains, as a minimum, the following components:

- I. Legal authority for the CWS's CCC program.
- II. The CWS's policy establishing where backflow protection at or for service connections from the CWS is mandatory.
- III. The CWS's policy regarding ownership, installation, inspection/testing, and maintenance of backflow protection that the CWS is requiring at or for service connections from the CWS.
- IV. The CWS's procedures for evaluating customers' premises to establish the category of customer and the backflow protection being required at or for the service connection(s) from the CWS to the customer.
- V. The CWS's procedures for maintaining CCC program records.

Component I: Legal authority for the CWS's CCC program (i.e., an ordinance, a bylaw or resolution, or water service rules and regulations).

A. On May 10, 1994, the City adopted Ordinance 427, subsequently amended by Ordinance 603 (collectively, the "Ordinance"), establishing and implementing the City of Panama City Beach Cross-Connection Program dated April 12, 1994. Pursuant to that Ordinance, the City has adopted Resolution No. 20-140 which is included in Appendix A. The resolution approves substantial updates to the City's CCC program and references the following CWS policies:

- The CWS's policy establishing where backflow protection at or for service connections from the CWS is mandatory.
- The CWS's policy regarding ownership, installation, inspection/testing, and maintenance of backflow protection that the CWS is requiring at or for service connections from the CWS.

B. *Definitions.* Unless otherwise defined, all CCC-related terms used in this CCC program plan have the same definitions as those contained in Rules 62-550.200 and 62-555.360, F.A.C.

Customer, as used herein, means the property owner and/or occupant of the premises served by the CWS (i.e., whoever interfaces with the CWS regarding water service).

Component II: The CWS's policy establishing where backflow protection at or for service connections from the CWS is mandatory.

This policy applies to all new or existing customers.

The following minimum backflow protection shall be provided at or for service connections from the CWS to the following categories of customers:

Category of Customer	Minimum Backflow Protection ¹ to Be Provided at or for the Service Connection from the CWS to the Customer
Beverage processing plant, including any brewery	DC if the plant presents a low hazard ² ; or RP if the plant presents a high hazard ²
Cannery, packing house, rendering plant, or any facility where fruit, vegetable, or animal matter is processed, excluding any premises where there is only a restaurant or food service facility	RP
Car wash	RP
Chemical plant or facility using water in the manufacturing, processing, compounding, or treatment of chemicals, including any facility where a chemical that does not meet the requirements in paragraph 62-555.320(3)(a), F.A.C., is used as an additive to the water	RP

Category of Customer	Minimum Backflow Protection ¹ to Be Provided at or for the Service Connection from the CWS to the Customer
Dairy, creamery, ice cream plant, cold-storage plant, or ice manufacturing plant	RP ³
Dye plant	RP
Film laboratory or processing facility or film manufacturing plant, excluding any small, noncommercial darkroom facility	RP
Hospital; medical research center; sanitarium; autopsy facility; medical, dental, or veterinary clinic where surgery is performed; or plasma center	RP
Laboratory, excluding any laboratory at an elementary, middle, or high school	RP
Laundry (commercial), excluding any self-service laundry or Laundromat	RP
Marine repair facility, marine cargo handling facility, or boat moorage	RP
Metal manufacturing, cleaning, processing, or fabricating facility using water in any of its operations or processes, including any aircraft or automotive manufacturing plant	DC if the facility presents a low hazard ² ; or RP if the facility presents a high hazard ²
Mortuary	RP
Premises where oil or gas is produced, developed, processed, blended, stored, refined, or transmitted in a pipeline or where oil or gas tanks are repaired or tested, excluding any premises where there is only a fuel dispensing facility	RP
Premises where there is an auxiliary or reclaimed water system ^{4,5}	<p>A. At or for a residential service connection⁶: DuC⁷</p> <p>B. At or for a non-residential service connection⁶: DC if the auxiliary or reclaimed water system presents a low hazard^{8,9}; or RP if the auxiliary or reclaimed water system presents a high hazard^{8,9}</p>
Premises where there is a cooling tower	RP
<p>Premises where there is an irrigation system that is using potable water and that...</p> <p>I. Is connected directly to the CWS's distribution system via a dedicated irrigation service connection</p> <p>II. Is connected internally to the customer's plumbing system</p>	<p>I. At or for a residential or non-residential dedicated irrigation service connection⁶: PVB if backpressure cannot develop in the downstream piping¹⁰; or RP if backpressure could develop in the downstream piping¹⁰</p> <p>II. None¹¹</p>

Category of Customer	Minimum Backflow Protection ¹ to Be Provided at or for the Service Connection from the CWS to the Customer
<p>Premises where there is a wet-pipe sprinkler, or wet standpipe, fire protection system that is using potable water and that...</p> <p>I. Is connected directly to the CWS's distribution system via a dedicated fire service connection¹²</p> <p>II. Is connected internally to the customer's plumbing system</p>	<p>I.A. At or for a residential dedicated fire service connection⁶: DuC if the fire protection system contains no chemical additives and is not connected to an auxiliary water system⁴; or RP/RPDA if the fire protection system contains chemical additives or is connected to an auxiliary water system^{4,13}</p> <p>I.B. At or for a non-residential dedicated fire service connection⁶: DC/DCDA if the fire protection system contains no chemical additives and is not connected to an auxiliary water system⁴; or RP/RPDA if the fire protection system contains chemical additives or is connected to an auxiliary water system^{4,13}</p> <p>II. None¹¹</p>
Radioactive material processing or handling facility or nuclear reactor	RP
Paper products plant using a wet process	RP
Plating facility, including any aircraft or automotive manufacturing plant	RP
Restricted-access facility	RP
Steam boiler plant	RP
Tall building – i.e., a building with five or more floors at or above ground level	DC if the customer has no potable water distribution lines connected to the suction side of a booster pump; or RP if the customer has one or more potable water distribution lines connected to the suction side of a booster pump
Wastewater treatment plant or wastewater pumping station	RP
Customer supplied with potable water via a temporary or permanent service connection from a CWS fire hydrant	Varies ¹⁴

¹ Means of backflow protection, listed in an increasing level of protection, include the following: a dual check device (DuC); a double check valve assembly (DC) or double check detector assembly (DCDA); a pressure vacuum breaker assembly (PVB); a reduced-pressure principle assembly (RP) or reduced-pressure principle detector assembly (RPDA); and an air gap. A PVB may not be used if backpressure could develop in the downstream piping.

² The CWS shall determine the degree of hazard. "Low hazard" or "non-health hazard" and "high hazard" or "health hazard" are defined in American Water Works Association Manual of Water Supply Practices—M14, Third Edition, *Recommended Practice for Backflow Prevention and Cross-Connection Control* as follows:

- "Non-health hazard (low hazard)" means a cross-connection or potential cross-connection

- involving any substance that generally would not be a health hazard but would constitute a nuisance or be aesthetically objectionable if introduced into the potable water supply.
- "Health hazard (high hazard)" a cross-connection or potential cross-connection involving any substance that could, if introduced into the potable water supply, cause death or illness, spread disease, or have a high probability of causing such effects.
- ³ A DC may be provided if it was installed before 5-5-14; and if such a DC is replaced on or after 5-5-14, it may be replaced with another DC.
- ⁴ For the purpose of this table, "auxiliary water system" means a pressurized system of piping and appurtenances using auxiliary water, which is water other than the potable water being supplied by the CWS and which includes water from any natural source such as a well, pond, lake, spring, stream, river, etc., includes reclaimed water, and includes other used water or industrial fluids described in American Water Works Association Manual of Water Supply Practices—M14, Third Edition, *Recommended Practice for Backflow Prevention and Cross-Connection Control*; however, "auxiliary water system" specifically excludes any water recirculation or treatment system for a swimming pool, hot tub, or spa. (Note that reclaimed water is a specific type of auxiliary water and a reclaimed water system is a specific type of auxiliary water system.)
- ⁵ The Department of Environmental Protection shall allow an exception to the requirement for backflow protection at or for a residential or non-residential service connection from a CWS to premises where there is an auxiliary or reclaimed water system if all of the following conditions are met:
- The CWS is distributing water only to land owned by the owner of the CWS.
 - The owner of the CWS is also the owner of the entire auxiliary or reclaimed water system up to the points of auxiliary or reclaimed water use.
 - The CWS conducts at least biennial inspections of the CWS and the entire auxiliary or reclaimed water system to detect and eliminate any cross-connections between the two systems.
- ⁶ For the purpose of this table, "residential service connection" means any service connection, including any dedicated irrigation or fire service connection, that is two inches or less in diameter and that supplies water to a building, or premises, containing only dwelling units; and "non-residential service connection" means any other service connection.
- ⁷ A DuC may be provided only if there is no known cross-connection between the plumbing system and the auxiliary or reclaimed water system on the customer's premises. Upon discovery of any cross-connection between the plumbing system and any reclaimed water system on the customer's premises, the CWS shall ensure that the cross-connection is eliminated. Upon discovery of any cross-connection between the plumbing system and any auxiliary water system other than a reclaimed water system on the customer's premises, the CWS shall ensure that the cross-connection is eliminated or shall ensure that the backflow protection provided at or for the service connection is equal to that required at or for a non-residential service connection.
- ⁸ A reclaimed water system using reclaimed water regulated under Part III of Chapter 62-610, F.A.C., is a low hazard unless the reclaimed water is stored with surface water in a pond that is part of a stormwater management system, in which case the system is a high hazard; an auxiliary water system using well water is a low hazard unless determined otherwise by the CWS; an auxiliary water system using industrial fluids or used water other than reclaimed water is a high hazard unless determined otherwise by the CWS; an auxiliary or reclaimed water system using reclaimed water not regulated under Part III of Chapter 62-610, F.A.C., or surface water is a high hazard.
- ⁹ Upon discovery of any cross-connection between the plumbing system and any reclaimed water system on the customer's premises, the CWS shall ensure that the cross-connection is eliminated.
- ¹⁰ A DC may be provided if both of the following conditions are met:
- The dedicated irrigation service connection initially was constructed before 5-5-14.
 - No chemicals are fed into the irrigation system.
- ¹¹ The CWS may rely on the internal backflow protection required under the *Florida Building Code* or the predecessor State plumbing code. The CWS may, but is not required to, ensure that such internal backflow protection is inspected/tested and maintained the same as backflow protection

provided at or for service connections from the CWS.

¹² The Department of Environmental Protection shall allow an exception to the requirement for backflow protection at or for a residential or non-residential dedicated fire service connection from a CWS to a wet-pipe sprinkler, or wet standpipe, fire protection system if both of the following conditions are met:

- The fire protection system was installed and last altered before 5-5-14.
- The fire protection system contains no chemical additives and is not connected to an auxiliary water system as defined in Footnote 4.

¹³ Upon discovery of any cross-connection between the fire protection system and any reclaimed water system on the customer's premises, the CWS shall ensure that the cross-connection is eliminated.

¹⁴ The CWS shall ensure that backflow protection commensurate with the degree of hazard is provided at or for the service connection from its fire hydrant.

Consideration for Fire Service Lines

Fire service lines may feed internal fire sprinkling systems, hose connections, storage tanks, fire hydrants and other types of suppression systems thus the types of fire suppression is classified on the basis of water source and arrangements of the water supply. AWWA categorizes fire suppression systems into six (6) distinct classes (Class 1 through Class 6.) The description and plumbing for the variety of possible fire suppression plumbing arrangements is beyond the scope of this document and for any fire service line that includes the connection of any plumbing beyond fire sprinkling systems, the reader is referred to AWWA Recommended Practices for Backflow Prevention and Cross-Connection Control M14 and NFPA, Chapter 13.

Fire service lines connected directly to public water mains only where no pumps, tanks, and there are no reservoirs, or physical connection from other water supplies and there are no antifreeze or other additives of any kind and where all sprinkler drains discharge to the atmosphere, dry wells, or other safe drains or outlets may not constitute a health hazard condition. However, if any of the following conditions exist backflow prevention is required.

Examples of Special Conditions Requiring Backflow Prevention Assemblies on Fire Sprinkling Systems

1. Underground fire sprinkler pipelines parallel to and within 10 ft (3 m) horizontally of sewer pipelines or other pipelines carrying significantly toxic materials.
2. When water is supplied to a site or an area from two or more services of a water utility or from two different water utilities.
3. Occupancies (or changes in occupancies) that involve the use, storage, or handling of types and quantities of materials in a manner that could present a significant health hazard to the domestic supply.
4. Premises with unusually complex piping systems (usually these premises will have an approved backflow-prevention assembly on their domestic service piping).
5. Systems with pumper connections in which non-toxic corrosion inhibitors or other non-toxic chemicals are added to tanks of fire trucks, or where the water purveyor cannot be assured of the potability of the input to the pumper connection.

Source: AWWA Recommended Practices for Backflow Prevention And Cross-Connection Control M14.

Because of the potential for Cross-Connections from internal plumbing or for consideration of the conditions listed above, backflow prevention assemblies are often required by the water system. At a minimum, for service lines supplying fire sprinkler systems only, the service line should be protected by a minimum of a Double Check Valve Assembly.

Component III: The CWS's policy regarding ownership, installation, inspection/testing, and maintenance of backflow protection that the CWS is requiring at or for service connections from the CWS.

- A. Except for dual check devices (DuC), the customer shall own, and shall be responsible for installation, inspection/testing, and maintenance of, any backflow protection required at or for a service connection from the CWS. The CWS shall own, and shall be responsible for installation and maintenance of, any DuC required at a service connection from the CWS; however, the customer shall be responsible for installation and maintenance of the thermal expansion control that is necessary, and required under the *Florida Building Code*, where a DuC is installed at a service connection to a customer using storage water heating equipment. At least 60 days before the CWS installs a DuC at the service connection to a customer, the CWS will notify the customer in writing and advise the customer to install thermal expansion control if the customer's plumbing system includes storage water heating equipment but does not include thermal expansion control. (A notice/letter is included in Appendix C.)

The following table shows the schedule that the CWS will follow for installation of backflow protection required at or for service connections.

Type of Service Connection	Schedule
New service connection to a customer in a category listed in Component II.	Before water service is initiated.
Existing—i.e., previously constructed—service connection to a premises where there is a reclaimed water system.	Before reclaimed water service is initiated.
Existing—i.e., previously constructed—service connection where the CWS will install a dual check device (DuC).	At least 60 days after the customer receives written notification from the CWS advising the customer to install thermal expansion control if the customer's plumbing system includes storage water heating equipment but does not include thermal expansion control. (A notice/letter is included in Appendix C.) If the service connection is to a premises where there is an auxiliary water system, the CWS shall deliver the aforementioned written notification within 30 days after the CWS discovers the auxiliary water system and shall install the DuC 60 to 90 days after the customer receives the aforementioned written notification.

Type of Service Connection	Schedule
Existing—i.e., previously constructed—service connection to a customer in any category listed in Component II except premises where there is a reclaimed water system or service connections where the CWS will install a DuC.	Within 60 days after the CWS notifies the customer in writing to install backflow protection at or for the service connection. (A notice/letter is included in Appendix C.)

B. All new backflow protection required at or for service connections from the CWS shall conform to, or comply with, the following standards:

- New dual check devices (DuC) shall conform to the latest edition of American Society of Sanitary Engineering (ASSE) Standard 1024 or Canadian Standards Association (CSA) Standard B64.6 or B64.6.1.
- New double check valve assemblies shall conform to the latest edition of ASSE Standard 1015, American Water Works Association (AWWA) Standard C510, or CSA Standard B64.5.
- New double check detector assemblies shall conform to the latest edition of ASSE Standard 1048.
- New pressure vacuum breaker assemblies shall conform to the latest edition of ASSE Standard 1020 or CSA Standard B64.1.2.
- New reduced-pressure principle assemblies shall conform to the latest edition of ASSE Standard 1013, AWWA Standard C511, or CSA Standard B64.4.
- New reduced-pressure principle detector assemblies shall conform to the latest edition of ASSE Standard 1047.
- New air gaps shall comply with the latest edition of American Society of Mechanical Engineers Standard A112.1.2.

Additionally, all new customer-owned backflow preventers required at or for dedicated fire service connections from the CWS shall be listed by a nationally recognized testing laboratory, such as Underwriters Laboratories, Inc., or Factory Mutual, Inc., pursuant to Chapter 633, Florida Statutes.

New DuC devices required at or for service connections from the CWS will be installed immediately downstream of the water meter and in the meter box. All other backflow protection required at or for service connections from the CWS shall be installed downstream from, and within five feet after, the CWS's water meter box or the customer's property line unless a deviation is approved by the CWS. The CWS will consider, and may approve, on a case-by-case basis, deviations requested and justified in writing; but in no case shall there be any outlet, tee, tap, or connection of any type to or from the water piping between the water meter, or property line, and the required backflow protection.

All new backflow protection required at or for service connections from the CWS shall be installed in accordance with the manufacturer's instructions and the installation criteria in American Water Works Association Manual of Water Supply Practices—M14, Third Edition, *Recommended Practice for Backflow Prevention and Cross-Connection Control*. Installation criteria in the third edition of M14 are reproduced in Appendix B. Additionally, all new customer-owned backflow preventers required at or for dedicated fire service connections from the CWS shall be installed in accordance with applicable

National Fire Protection Association standards adopted in Chapter 69A-3, Florida Administrative Code, and all other new customer-owned backflow protection required at or for service connections from the CWS shall be installed in accordance with the latest edition of the *Florida Building Code*.

C. All air gaps (AGs) required at or for service connections from the CWS shall be inspected at least annually. Persons inspecting AGs required at or for service connections from the CWS shall be a certified or registered plumbing contractor or shall be a backflow preventer tester holding a current certification from one of the following organizations or schools:

- The American Backflow Prevention Association;
- The American Society of Sanitary Engineering;
- The American Water Works Association;
- The Florida Water and Pollution Control Operators Association;
- The University of Florida Center for Training, Research, and Education for Environmental Occupations.

D. All backflow preventer assemblies (i.e., double check valve assemblies and double check detector assemblies; pressure vacuum breaker assemblies; and reduced-pressure principle assemblies and reduced-pressure principle detector assemblies) required at or for non-residential service connections from the CWS shall be tested after installation or repair and at least annually thereafter and shall be repaired if they fail to meet performance standards. All backflow preventer assemblies required at or for residential service connections from the CWS shall be tested after installation or repair and at least biennially (once every two years) thereafter and shall be repaired if they fail to meet performance standards. Residential service connections are service connections, including dedicated irrigation or fire service connections that are two inches or less in diameter and that supply water to a building, or premises, containing only dwelling units; all other service connections are non-residential service connections.

Persons testing backflow preventer assemblies required at or for dedicated fire service connections from the CWS shall be a certified Fire Protection System Contractor I or II pursuant to Chapter 633, Florida Statutes. Persons testing backflow preventer assemblies required at or for all other service connections from the CWS shall be a certified or registered plumbing contractor or shall be a backflow preventer tester holding a current certification from one of the following organizations or schools:

- The American Backflow Prevention Association;
- The American Society of Sanitary Engineering;
- The American Water Works Association;
- The Florida Water and Pollution Control Operators Association;
- The University of Florida Center for Training, Research, and Education for Environmental Occupations; or
- Any other organization or school approved in writing by the CWS.

Backflow preventer assemblies required at or for service connections from the CWS

shall be tested using the procedures in one of the following standards or manuals:

- The latest edition of American Society of Sanitary Engineering Standards 5013, 5015, 5020, 5047, and 5048;
- The latest edition of Canadian Standards Association Standard B64.10.1;
- The latest edition of *Backflow Prevention: Theory & Practice* by the University of Florida Center for Training, Research, and Education for Environmental Occupations;
- The latest edition of the *Manual of Cross-Connection Control* by the University of Southern California Foundation for Cross-Connection Control and Hydraulic Research Center; or
- Any other standard or manual approved in writing by the CWS.

Testing equipment used to test backflow preventer assemblies required at or for service connections from the CWS shall be verified/calibrated at least annually in accordance with the equipment manufacturer's recommendations.

E. All dual check devices (DuC) required at service connections from the CWS shall be refurbished or replaced at least once every 10 years or at a lesser frequency if the CWS determines and documents that the lesser frequency is appropriate based on data from spot-testing DuC devices at service connections or based on data from backflow sensing meters at service connections.

Component IV: *The CWS's procedures for evaluating customers' premises to establish the category of customer and the backflow protection being required at or for the service connection(s) from the CWS to the customer.*

A. The CWS will evaluate the proposed plan documents for new facilities to establish the category prior to construction and confirm compliance with the CWS Program before the CWS begins supplying water to the service connection.

B. The CWS will evaluate the customer's premises at an existing—i.e., previously constructed—service connection whenever any of the following events occur:

- Whenever the customer connects to a reclaimed water distribution system. The CWS will coordinate with the reclaimed water supplier to ensure that reclaimed water service is not turned on until appropriate backflow protection is provided at the potable water service connection.
- Whenever an auxiliary water system is discovered on the customer's premises.
- Whenever a prohibited or inappropriately protected cross-connection is discovered on the customer's premises.
- Whenever the customer's premises is altered under a building permit in a manner that could change the backflow protection required at or for a service connection to the customer. The CWS will coordinate with the local building department so the CWS will know when building permits are being applied for or issued.

C. To evaluate the customer's premises at a service connection from the CWS, the CWS

will use "a water use questionnaire" and, if necessary, will also review construction plans or conduct an on-site inspection. ("Water use questionnaire" forms are included in Appendix C.)

Component V: The CWS's procedures for maintaining CCC program records.

A. The CWS will maintain, in either electronic or paper format, a current inventory of all backflow protection required at or for service connections from the CWS. The inventory will include the following for each service connection where backflow protection is required:

- The service connection number or other identification number used by the CWS;
- The service connection address;
- The service connection category (i.e., non-residential or residential) and subcategory (standard, dedicated irrigation, or dedicated fire);
- The location of the backflow protection at/for the service connection;
- The type of hazard isolated (i.e., the category of customer);
- The date when backflow protection was initially installed at or for the service connection;
- The type of current backflow protection (i.e., air gap, reduced-pressure principle assembly, reduced-pressure principle detector assembly, pressure vacuum breaker assembly, double check valve assembly, double check detector assembly, or dual check device (DuC));
- If the type of current backflow protection is a backflow preventer assembly, the size, manufacturer, model, serial number, and date installed; and
- If the type of backflow protection is a DuC, the size, manufacturer, model, date installed, and if any DuC is refurbished (instead of replaced), the date refurbished.

B. The CWS will maintain, in either electronic or paper format, records of the installation, inspection/testing, and repair of all backflow protection required at or for service connections from the CWS.

The inventory described in Component V.A. will include the date when backflow protection was initially installed at or for any service connection where backflow protection is required. Also, the inventory described in Component V.A. will include the date when any current backflow preventer assembly or any current dual check device (DuC) was installed. Furthermore, if any DuC is refurbished (instead of replaced), the inventory described in Component V.A. will include the date the DuC was refurbished.

Records of the inspection of air gaps (AGs) required at or for service connections from the CWS will be maintained by keeping either an electronic or paper copy of AG inspection reports. (An AG inspection report form is included in Appendix C.) Records of the testing and repair of backflow preventer assemblies required at or for service connections from the CWS will be maintained by keeping either an electronic or paper

copy of backflow preventer assembly testing and repair reports. (A backflow preventer assembly testing and repair report form is included in Appendix C.) All AG inspection reports and all backflow preventer assembly testing and repair reports will be kept for not less than 10 years.

- C. The CWS will prepare and submit CCC program annual reports. The first annual report will cover calendar year 2020, and subsequent annual reports will cover each calendar year thereafter. Each annual report will be prepared using the latest version of Form 62-555.900 (13), Cross-Connection Control Program Annual Report. Each annual report will be submitted to the appropriate Department of Environmental Protection district office or Approved County Health Department within three months after the end of the calendar year covered by the report.

Component VI: *Penalty for Non-compliance.*

Water service will be discontinued after reasonable notice to the Customer if a violation of this Ordinance exists on the premises, and such other precautionary measures may be taken as are deemed necessary to eliminate any danger to the potable water. Water service will be discontinued if the proper backflow prevention assembly is not installed or not tested at least annually or not repaired when the assembly fails to meet minimum design standards. Water service shall not be restored until the danger had been eliminated in compliance with the provisions of this Ordinance.

Program Administration Documents

Appendix A contains resolution establishing a Cross Connection Control Program

Appendix B contains installation criteria for backflow devices

Appendix C contains forms and notices/letters used to administer the CCC program

Appendix D contains test and maintenance report form for cross connection devices

Appendix E contains definitions

The CWS will notify in writing each customer who owns an air gap (AG) or backflow preventer assembly required at or for a service connection and will request that the customer have the AG inspected or backflow preventer assembly tested. Notices/letters will be delivered at least 30 days before the due date of the inspection or test. Notices/letters will specify that the inspection or test report must be returned to the CWS within 60 days after the date of the notice/letter.

APPENDIX A
RESOLUTION ESTABLISHING CROSS CONNECTION PROGRAM

**APPENDIX B
INSTALLATION CRITERIA**

Installation Criteria for a Dual Check Device (DuC)

- A DuC must be installed in the orientation as it was approved by the testing agency.
- A DuC must not be subjected to conditions that would exceed its maximum working water pressure and temperature rating. The increased pressure that can happen from creation of a closed system also must be evaluated because excessive pressure can damage the device or other plumbing components.
- A DuC should be sized hydraulically, taking into account both volume requirements and pressure loss through the device.
- A pipeline should be thoroughly flushed before a DuC is installed to ensure that no dirt or debris is delivered into the device because dirt or debris might adversely affect the DuC device's working abilities.
- A DuC shall be installed where it can be inspected or replaced as necessary.

Installation Criteria for a Double Check Valve Assembly (DC) or Double Check Detector Assembly (DCDA)

- A DC or DCDA must be installed in the orientation as it was approved by the testing agency with no field modifications allowed.
- A DC or DCDA must not be subjected to conditions that would exceed its maximum working water pressure and temperature rating. The increased pressure that can happen from the creation of a closed system also must be evaluated to prevent damage to the assembly or other plumbing-system components.
- A DC or DCDA shall be sized hydraulically, taking into account both volume requirements and pressure loss through the assembly.
- A DC or DCDA shall not be installed in a pit or below grade.
- A pipeline should be thoroughly flushed before a DC or DCDA is installed to ensure that no dirt or debris is delivered to the assembly because dirt or debris might adversely affect the assembly's working abilities.
- A DC or DCDA shall be installed a minimum of 12 inches above the surrounding grade and floodplain. The installation shall not be installed where platforms, ladders, or lifts are required for access. If an assembly must be installed higher than 5 feet above grade, a permanent platform shall be installed around the assembly to provide access for workers.
- A DC or DCDA shall be installed where it can be easily field-tested and repaired as necessary. The assembly shall have adequate clearance around it to facilitate testing, disassembly, and assembly of the DC or DCDA.
- If a DC or DCDA must be subjected to environmental conditions that could freeze or heat the assembly beyond working temperatures, some means of protection should be installed to provide the correct temperature environment in and around the assembly.

Installation Criteria for a Pressure Vacuum Breaker Assembly (PVB)

- A PVB must be installed in the orientation as it was approved by the testing agency.
- A PVB must not be subjected to conditions that would exceed its maximum working water pressure and temperature rating. The increased pressure that can happen from the creation of a closed system also must be evaluated because a PVB cannot be exposed to backpressure.
- A PVB shall not be installed where it is subjected to backpressure.
- A PVB should be sized hydraulically, taking into account both volume requirements and pressure loss through the assembly.
- A pipeline should be thoroughly flushed before a PVB is installed to ensure that no dirt or debris is delivered into the assembly because dirt or debris might affect the PVB's working abilities.
- A PVB must not be installed in a pit or below grade where the air inlet could become submerged in water or where fumes could be present at the air inlet because this installation might allow water or fumes to enter the assembly.
- A PVB shall be installed a minimum of 12 inches above the highest point of use and any downstream piping supplied from the assembly. The installation should not be installed where platforms, ladders, or lifts are required for access. If an assembly must be installed higher than 5 feet above grade, a permanent platform should be installed around the assembly to provide access for workers.
- A PVB shall be installed where it can be easily field-tested and repaired as necessary. The assembly shall have adequate clearance around it to facilitate disassembly, repairs, testing, and other maintenance.
- A PVB may periodically discharge water from the air inlet. The effect of this discharge on the area around the assembly must be evaluated.
- If a PVB must be subjected to environmental conditions that could freeze or heat the assembly beyond its working temperatures, some means of protection should be installed to provide the correct temperature environment in and around the assembly.

Installation Criteria for a Reduced-Pressure Principle Assembly (RP) or Reduced-Pressure Principle Detector Assembly (RPDA)

- An RP or RPDA must be installed in the orientation as it was approved by the testing agency.
- An RP or RPDA must not be subjected to conditions that would exceed its maximum working water pressure and temperature rating. The increased pressure that can occur because of the creation of a closed system also must be evaluated because excessive backpressure can damage the assembly or other plumbing components.
- An RP or RPDA should be sized hydraulically, taking into account both volume requirements and pressure loss through the assembly.
- A pipeline should be thoroughly flushed before an RP or RPDA is installed to ensure that no dirt or debris is delivered into the assembly because dirt or debris might adversely affect the assembly's working abilities.
- An RP or RPDA must not be installed in a pit or below grade where the relief valve could become submerged in water or where fumes could be present at the relief-valve discharge because this installation might allow water or fumes to enter the assembly.
- An RP or RPDA shall be installed a minimum of 12 inches above the relief-valve discharge-port opening and the surrounding grade and floodplain. The installation should not be installed where platforms, ladders, or lifts are required for access. If an assembly is installed higher than 5 feet above grade, a permanent platform should be installed around the assembly to provide access for workers.
- An RP or RPDA shall be installed where it can be easily tested and repaired as necessary. The assembly shall have adequate clearance around it to facilitate disassembly, repairs, testing, and other maintenance.
- An RP or RPDA might periodically discharge water from the relief valve. The effect of this discharge from the relief valve around the assembly must be evaluated. If the RP or RPDA discharge is piped to a drain, an air-gap separation must be installed between the relief-valve discharge opening and the drain line leading to the drain.
- If an RP or RPDA must be subjected to environmental conditions that could freeze or heat the assembly beyond its working temperatures, some means of protection should be installed to provide the correct temperature environment in and around the assembly.

Air Gap Description

- An air gap is a piping arrangement that provides an unobstructed vertical distance through free atmosphere between the lowest point of a water supply outlet and the overflow rim of an open, non-pressurized receiving vessel into which the outlet discharges.
- These vertical separations must be at least twice the effective opening (inside diameter) of the water supply outlet but never less than 1 inch.
- In locations where the outlet discharges within three times the inside diameter of the pipe from a single wall or other obstruction, the air gap must be increased to three times the effective opening but never less than 1.5 inches.
- In locations where the outlet discharges within four times the inside diameter of the pipe from two intersecting walls, the air gap must be increased to four times the effective opening but never less than 2 inches.
- Air gaps should not be approved for locations where there is potential for the atmosphere around the air gap to be contaminated nor should the inlet pipe be in contact with a contaminated surface or material.

**APPENDIX C
FORMS**

[City Letterhead]
[Insert Date]
[Insert Customer Name]
[Insert Customer Street Address]
[Insert Customer City, State, and Zip Code]

RE: [Insert service connection number]
[Insert service connection address]

Dear [Insert Customer Name]:

As required by the Florida Department of Environmental Protection and Rule 62-555.360, Florida Administrative Code, the City of Panama City Beach Water Supply System has updated its Cross-Connection Control (CCC) Program utilizing backflow protection at or for service connections from the water system in order to protect the water system from contamination caused by cross-connections on customers' premises. Under the new FDEP mandate, a backflow device is now required at water irrigation system meters.

This letter is to advise you that you need to have a backflow device installed. There are two types available, depending on the particulars of your property elevations and irrigation system installation.

We recommend you consult with a certified or registered plumbing contractor to determine the best solution for your specific needs. An appropriate device will need to be installed and tested within 60 days from the date of this notification letter. Your device will need to be tested annually by a licensed tester, repaired if necessary to meet the CCC Program requirements, and those results will be forwarded to the City. Failure to have the correct assembly installed will result in disconnection from the City system.

If you have any questions or need further information regarding the Cross-Connection Control Program, please contact Shedric Walker at (850) 233-5100 or by email, at swalker@pcb.gov.

Sincerely,

[], PCB Utilities Department

[City Letterhead]
[Insert Date]
[Insert Customer Name]
[Insert Customer Street Address]
[Insert Customer City, State, and Zip Code]

RE: [Insert service connection number]
[Insert service connection address]

Dear [Insert Customer Name]:

As required by the Florida Department of Environmental Protection and Rule 62-555.360, Florida Administrative Code, the City of Panama City Beach Water Supply System has updated its Cross-Connection Control (CCC) Program utilizing backflow protection at or for service connections from the water system in order to protect the water system from contamination caused by cross-connections on customers' premises. Under our CCC Program, we will install a backflow preventer in the meter box at the above referenced service connection.

This letter is to advise you that you might need to have thermal expansion control installed in the plumbing system connected to the above referenced service connection. When water is heated, it expands and requires more volume; this is called thermal expansion. A backflow preventer installed at a service connection will stop heated water in the customer's plumbing system from expanding back into the public water system; the backflow preventer creates what is called a closed plumbing system at the customer's premises. Thermal expansion in a closed plumbing system will cause an increase in pressure in the system. The increased pressure usually causes the temperature and pressure relief (T&P) valve on a water heater tank to open and discharge water from the water heater tank. But a T&P valve is not intended to be used for routine thermal expansion control, and if a T&P valve fails, the water heater tank might explode.

The current *Florida Building Code* requires that thermal expansion control shall be installed in closed plumbing systems using a water heater tank. **If your plumbing system includes a water heater tank but does not include thermal expansion control, you are advised to have thermal expansion control installed in your plumbing system within 60 days of the date of this letter.** We recommend you consult with a certified or registered plumbing contractor to determine the best solution for your specific needs.

If you have any questions or need further information regarding the Cross-Connection Control Program, please contact Shedric Walker at (850) 233-5100 or by email, at swalker@pcb.gov.

Sincerely,

[], PCB Utilities Department

[City Letterhead]

[date]

[Customer Name]

[Mailing Address]

[Mailing Address]

Dear Customer ,

As required by the Florida Department of Environmental Protection and Rule 62-555.360, Florida Administrative Code, the City of Panama City Beach Water Supply System has updated its Cross-Connection Control (CCC) Program utilizing backflow protection at or for service connections from the water system in order to protect the water system from contamination caused by cross-connections on customers' premises. Under our CCC program, the customer-owned backflow preventer assembly/device located at the above referenced water service connection is due for required testing to ensure that it is functioning properly.

Reference:

[Device Location/Business Name]

[Due Date]

[Serial #:]

A successful test of the device must be completed by a Certified Tester and the results sent to this department. If the assembly is at a fire service connection, the testing must be conducted by a certified Fire Protection System Contractor I or II. The test results must be received by our office no later than the due date indicated above.

If you have any questions or need further information regarding the Cross-Connection Control Program, please contact Shedric Walker at (850) 233-5100 or by email, at swalker@pcb.gov.

Your prompt attention to this matter would be greatly appreciated.

Sincerely,

[]

PCB Utilities Department

Enclosures: Backflow Preventer Assembly Testing & Maintenance Report & partial list of certified testers

"Water Use Questionnaire" for Non-Residential Service Connections

Public Water System (PWS) No. 1030515 PWS Name City of Panama City Beach Water Supply System

Customer's Name/Address: _____

Customer's Phone No: _____

Service Connection Number(s): _____

Service Connection Address: _____

Description of Customer's Business or Premises at Service Connection Address: _____

Is your business or premises in one or more of the following categories (check all that apply)?

Beverage processing plant, including any brewery	
Cannery, packing house, rendering plant, or any facility where fruit, vegetable, or animal matter is processed, excluding any premises where there is only a restaurant or food service facility	
Chemical plant or facility using water in the manufacturing, processing, compounding, or treatment of chemicals, including any facility where a chemical that does not meet the requirements in Rule 62-555.320(3)(a), F.A.C., is used as an additive to the water	
Dairy, creamery, ice cream plant, cold-storage plant, or ice manufacturing plant	
Dye plant	
Film laboratory or processing facility or film manufacturing plant, excluding any small, noncommercial darkroom facility	
Hospital; medical research facility; sanitarium; autopsy facility; medical, dental, or veterinary clinic where surgery is performed; or plasma center	
Laboratory, excluding any laboratory at an elementary, middle, or high school	
Laundry (commercial), excluding any self-service laundry or Laundromat	
Marine repair facility, marine cargo handling facility, or boat moorage	
Metal manufacturing, cleaning, processing, or fabricating facility using water in any of its operations or processes, including any aircraft or automotive manufacturing plant	
Mortuary	
Premises where oil or gas is produced, developed, processed, blended, stored, refined, or transmitted in a pipeline or where oil or gas tanks are repaired or tested, excluding any premises where there is only a fuel dispensing facility	
Premises where there is an auxiliary or reclaimed water system	
Premises where there is a cooling tower	
Premises where there is an irrigation system that is using potable water and that is connected directly to the PWS's distribution system via a dedicated irrigation service connection	
Premises where there is a wet-pipe sprinkler, or wet standpipe, fire protection system that is using potable water and that is connected directly to the PWS's distribution system via a dedicated fire service connection	
Radioactive material processing or handling facility or nuclear reactor	
Paper products plant using a wet process	
Plating facility, including any aircraft or automotive manufacturing plant	
Restricted-access facility	
Steam boiler plant	
Tall building—i.e., a building with five or more floors at or above ground level	
Wastewater treatment plant or wastewater pumping station	

Customer Representative's

Signature: _____ Date: _____

Customer Representative's Printed Name: _____

“Water Use Questionnaire” for Residential Service Connections

Public Water System No. 1030515

Public Water System Name Panama City Beach Water Supply System

Customer's Name/Address: _____

Customer's Phone No: _____

Service Connection Number(s): _____

Service Connection Address: _____

Does your premises have one or more of the following (check all that apply)?

An auxiliary or reclaimed water system*	<input type="checkbox"/>
An irrigation system that is using potable water and that is connected directly to the PWS's distribution system via a separate, dedicated irrigation service connection	<input type="checkbox"/>
A wet-pipe sprinkler, or wet standpipe, fire protection system that is using potable water and that is connected directly to the PWS's distribution system via a separate, dedicated fire service connection	<input type="checkbox"/>

* "Auxiliary water system" means a pressurized system of piping and appurtenances using auxiliary water, which is water other than the potable water being supplied by the public water system and which includes water from any natural source such as a well, pond, lake, spring, stream, river, etc., and includes reclaimed water; however, "auxiliary water system" specifically excludes any water recirculation or treatment system for a swimming pool, hot tub, or spa. (Note that reclaimed water is a specific type of auxiliary water and a reclaimed water system is a specific type of auxiliary water system.)

Customer's Signature: _____ Date: _____

Customer's Printed Name: _____

Air Gap Inspection Report

Public Water System (PWS) No.: 1030515

PWS Name: Panama City Beach Water Supply System

Customer's Name/Address: _____

Service Connection No.: _____

Service Connection Address: _____

Service Connection Category: non-residential residential

Service Connection Subcategory: standard irrigation fire

Location of Air Gap at/for Service Connection: _____

Comments:

I certify that the air gap at/for the above identified service connection complies with the requirements of the above identified PWS and has not been bypassed or otherwise been made ineffective.

Inspector's Signature: _____ Date: _____

Inspector's Printed Name: _____

Inspector's Qualification:* _____

*The inspector's plumbing contractor certification or registration number or the inspector's backflow preventer tester certification organization and number.

APPENDIX D
TEST AND MAINTENANCE REPORT

TEST & MAINTENANCE REPORT
CROSS CONNECTION CONTROL DEVICES

Name of Premise: _____

Street Address: _____

Device Location: _____

Type of Device: RPZ DC PVB Size: _____

Manufacturer & Model: _____ Serial Number: _____

Pressure Drop across First Check Valve: _____ psi Line Pressure at Time of Test: _____ psi

	Check Valve # 1	Check Valve #2	Differential Pressure Relief Valve	Pressure Vacuum Breaker
INITIAL	1. Leaked <input type="checkbox"/>	1. Leaked <input type="checkbox"/>	Opened at ____ lbs.	Air inlet opened at ____ lbs
	2. Closed tight <input type="checkbox"/>	2. Closed tight <input type="checkbox"/>	Did not open <input type="checkbox"/>	Did not open <input type="checkbox"/>
REPAIRS	Cleaned <input type="checkbox"/>	Cleaned <input type="checkbox"/>	Cleaned <input type="checkbox"/>	Check valve:
	Replaced: Rubber parts kits <input type="checkbox"/>	Replaced: Rubber parts kits <input type="checkbox"/>	Replaced: Rubber parts kits <input type="checkbox"/>	Leaked <input type="checkbox"/>
	C.V. assembly <input type="checkbox"/>	C.V. assembly <input type="checkbox"/>	C.V. assembly <input type="checkbox"/>	Closed tight <input type="checkbox"/>
	Or Disc <input type="checkbox"/>	Or Disc <input type="checkbox"/>	Or Disc <input type="checkbox"/>	Cleaned <input type="checkbox"/>
	O-rings <input type="checkbox"/>	O-rings <input type="checkbox"/>	O-rings <input type="checkbox"/>	Replaced: C.V. assembly <input type="checkbox"/>
	Seat <input type="checkbox"/>	Seat <input type="checkbox"/>	Seat <input type="checkbox"/>	Disc air inlet <input type="checkbox"/>
	Spring <input type="checkbox"/>	Spring <input type="checkbox"/>	Spring <input type="checkbox"/>	Spring <input type="checkbox"/>
	Stem/guide <input type="checkbox"/>	Stem/guide <input type="checkbox"/>	Stem/guide <input type="checkbox"/>	Retainer <input type="checkbox"/>
	Retainer <input type="checkbox"/>	Retainer <input type="checkbox"/>	Retainer <input type="checkbox"/>	Guide <input type="checkbox"/>
	Locknuts <input type="checkbox"/>	Locknuts <input type="checkbox"/>	Locknuts <input type="checkbox"/>	O-ring <input type="checkbox"/>
Other <input type="checkbox"/>	Other <input type="checkbox"/>	Other <input type="checkbox"/>	Other <input type="checkbox"/>	
FINAL	Closed tight <input type="checkbox"/>	Closed tight <input type="checkbox"/>	Opened at ____ lbs Reduced pressure	Satisfactory <input type="checkbox"/>

Remarks: _____

Initial test by: _____
 Certified Tester Number: _____ Date: _____
 Repaired by: _____ Date: _____
 Final test by: _____ Certified Tester Number: _____ Date: _____

**APPENDIX E
DEFINITIONS**

Definitions

Approved

Accepted by the City of Panama City Beach Utilities Director or his designated Representative.

Auxiliary Water Supply

Any water supply on or available to the premises other than the purveyor's approved public potable water supply. These auxiliary waters may include water from another purveyor's public water supply or any natural source(s) such as a well, spring, river, stream, harbor, etc., or "used waters" or "industrial fluids". These waters may be polluted or contaminated or they may be objectionable and constitute an unacceptable water source over which the water purveyor does not have sanitary control.

Backflow

The flow of water or other liquids, mixtures, or substances under pressure into the distribution piping of a potable water supply system from any source or sources other than its intended source.

Back-Siphonage

The flow of water or other liquids, mixtures, or substances into the distribution piping of a potable water supply system from any source other than its intended source caused by the sudden reduction of pressure in the potable water supply system.

Backflow Preventers

Air Gap (AG)

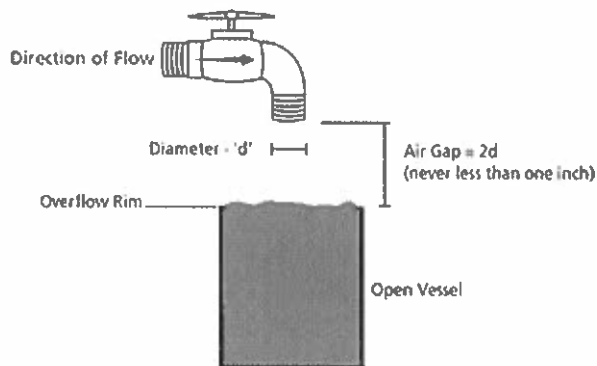

An air gap is a vertical, physical separation between the end of a water supply outlet and the flood-level rim of a receiving vessel. This separation must be at least twice the diameter of the water supply outlet and never less than one inch. An air gap is considered the maximum protection available against backpressure backflow or backsiphonage but is not always practical and can easily be bypassed.

An air gap is measured vertically from the lowest end of the supply pipe to the flood level rim or highest possible water level of the fixture or tank into which it discharges. In general, the separation must be twice the supply pipe inside diameter, but never less than one inch. The close proximity of walls or obstructions will necessitate the use of a larger air gap. A larger air gap will also be required if foaming materials are added to the reservoir so that foam does not back up into the supply pipe.

Advantages:

- Very safe and reliable if properly installed and maintained
- Provide maximum protection due to physical separation of potable and non-potable water
- Easy to inspect

Limitations:

- Easy to bypass or defeat with funnels or hoses
- Supply pressure is lost, requiring reservoir and additional pumping equipment
- Undesirable splashing may occur
- Incoming water may be exposed to airborne contaminants or lose residual chlorine

Reduced Pressure Principle Backflow Preventer (RP)

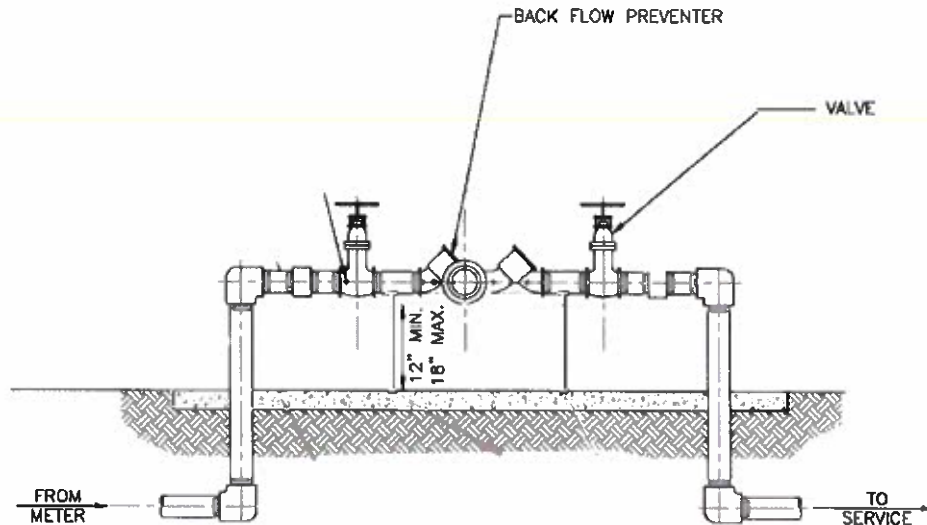

A Reduced Pressure Backflow Prevention Assembly may be used to isolate health hazards in place of an Air Gap. It consists of two independently acting check valves, an automatically operated pressure differential relief valve located between the two check valves, and watertight valves located at each end of the assembly, together with four properly located test cocks for testing the operation of the device. This assembly will indicate leakage through one or both check valves or the relief valve by the discharge of water from the relief valve port. During normal operation, both check valves remain closed until there is a demand for water. The differential relief valve remains closed because the inlet pressure is higher than the pressure in the intermediate zone. The second check remains open as water flows through the device. In opening and closing the check valves, the water pressure may be reduced by 4 to 20 psi depending upon the assembly design.

During a backpressure condition, pressure increases downstream of the assembly and both check valves close to prevent backflow. If the second check valve is prevented from closing tightly, leakage back into the zone between the check valves will increase the pressure in the zone and cause the relief valve to open. Water in the zone will then be discharged.

During backsiphonage, the supply pressure drops and the relief valve opens automatically and drains enough water from the zone to maintain pressure in the zone lower than the supply pressure. The second check valve closes to prevent downstream water from draining through the relief valve.

Advantages:

- Protects against both backpressure and backsiphonage
- Can be used under constant pressure
- An RP is effective against backpressure backflow and backsiphonage
- Malfunctioning is easily indicated by discharge of water from the relief valve.

Limitations:

- Pressure loss of 6-12 psi across the assembly and must be installed above grade

Double Check Valve Assembly (DC)

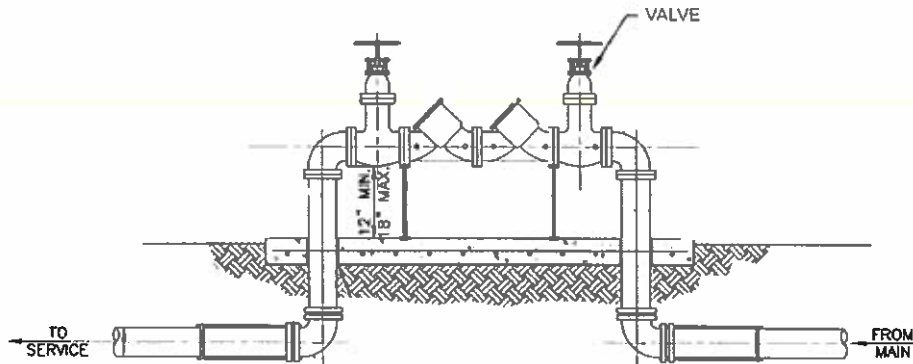

A Double Check Valve is effective against backpressure backflow and backsiphonage but should be used to isolate only non-health hazards.

A Double Check Valve Assembly consists of two single independently acting check valves with watertight valves located at each end of the assembly, and four properly located test cocks for testing the water tightness of each check valve. During normal operation, both check valves remain closed until there is a demand for water. In the event of backflow, both check valves close preventing reversal of flow.

Two standard plumbing check valves in series may not be used in place of the double check valve assembly due to the necessity for testing. The Double Check Valve Assembly is an integral assembly designed specifically for backflow prevention.

Advantages:

- Protect against backflow due to both backpressure and backsiphonage
- May be used under continuous pressure
- Little pressure loss occurs across the device

Limitations:

- No external indication of failure
- May only be used in low hazard situations

Residential Dual Check Valve (DuC)

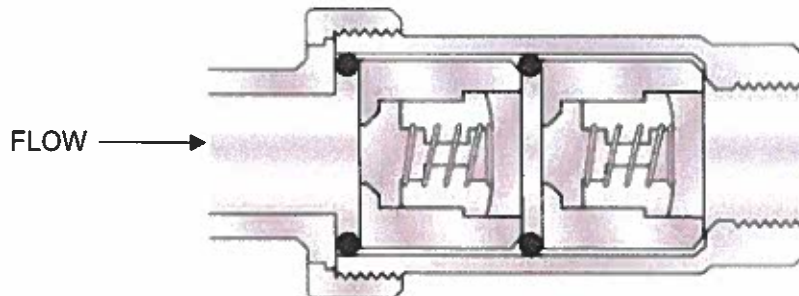

Dual check valves may not be used for health or high hazards. They are an acceptable solution for preventing potential backflow and backsiphonage for service connections in water service areas that are

also served with reclaimed water. They are sized for use on small supply lines (1" or less) and are to be installed immediately downstream of the meter.

Residential Dual Check Valve Backflow Preventers consist of two independently operating check valves. It usually does not include shutoff valves, may or may not be equipped with test cocks or ports, and is generally less reliable than a DCVA. During normal operation, both check valves remain closed until there is a demand for water. In the event of backflow, both checks close to prevent reversal of flow.

Dual Checks may be used for continuous pressure applications and will protect against both backsiphonage and backpressure

NOTE: Consideration must be given to thermal expansion problems that may arise in the home after installation of a dual check device.

Advantages:

- Protect against both backsiphonage and backpressure in low hazard situations
- May be used under continuous pressure
- Low initial installation cost
- May be Used for Reclaimed Water

Limitations:

- May be used only for residential applications
- No external indication of failure
- Must be replaced in compliance with program Component III E.

Pressure Vacuum Breaker (PVB)

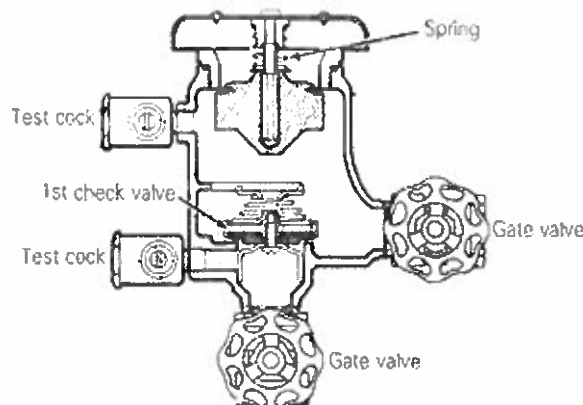

A PVB may be used to isolate high or low hazards but is effective against backsiphonage only. This assembly is intended to be used under constant pressure conditions.

It is a mechanical backflow preventer that consists of an independently acting, spring-loaded check valve and an independently acting, loaded air inlet valve on the discharge side of the check valve. It includes shutoff valves at each end of the assembly and is equipped with test cocks.

The pressure vacuum breaker uses loading to actuate the atmospheric vent only when backsiphonage occurs or when the line is depressurized. Two gate valves, test cocks and an additional check are also added. This assembly differs from the atmospheric vacuum breaker in that a spring has been added to the check valve.

Advantages:

- Sometimes less expensive than alternatives

Limitations:

- Does not protect against backflow due to backpressure.
- May only be used in non-health or low hazard situations
- Cannot be installed if chemicals are used.

Hose Bibb Vacuum Breaker (Isolation)

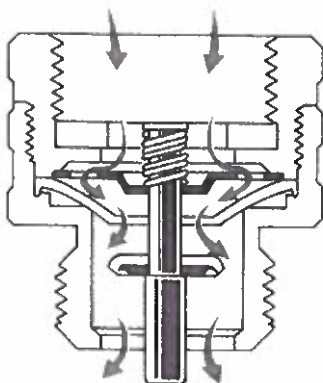

Hose bibb Vacuum Breakers are not approved for health or high hazard situations but provide an inexpensive means of isolating potential backsiphonage situation caused by connections of hoses to outside spigots.

The device consists of a spring loaded check valve that seals against an atmospheric outlet when water is flowing. When the water supply is turned off, the device vents to atmosphere, thus protecting against backsiphonage.

These assemblies are suitable only for isolation in situations where outside spigots may be used to connect hoses. Hoses pose both non-health and health threats. Health threats are introduced when water pressure is used in combination with a hose to apply fertilizers or herbicides. Hoses may also be unintentionally submerged in toxic or microbially contaminated liquids that can back siphon under the right conditions.

Advantages:

- Inexpensive method of isolating hoses
- Isolation of hose problems resolves most customer complaints

Limitations:

- Does not protect against backflow due to backpressure.
- May only be used in for isolation and is not acceptable for protection against health or high hazards.
- Will fail to operate properly if there is a shut-off valve installed downstream.

Contamination

Means an impairment of the quality of the potable water supply system by sewage, industrial fluids, or waste fluids, compounds, or other materials to a degree which creates an actual hazard to the public health through poisoning or through the spread of disease.

Cross-Connection

Any physical connection or arrangement of piping or fixtures between two otherwise separate piping systems, one of which contains potable water and the other non-potable water or industrial fluids of questionable safety, through which, or because of which, backflow or back-siphonage may occur into the potable water system. A

water service connection between a public potable water distribution system and a customer's water distribution system which is cross-connected to a contaminated fixture, industrial fluid system, or with potentially contaminated supply or auxiliary water system, constitutes one type

of cross-connection. Other types of cross-connections include connectors such as swing connections, removable sections, four-way valves, spools, dummy sections of pipe, swivel or change-over devices, sliding multiport tubes, solid connections, etc.

Cross-Connection, Controlled

A connection between a potable water system and a non-potable water system with an approved backflow prevention device properly installed that will continuously afford the protection commensurate with the degree of hazard.

Cross-Connection Control by Containment

The installation of an approved backflow prevention device at the water service connection to any customer's premises where it is physically and economically infeasible to find and permanently eliminate or control all actual or potential cross-connections within the customer's water system; or it shall mean the installation of an approved backflow prevention device on the service line leading to and supplying a portion of a customer's water system where there are actual or potential cross-connections which cannot be effectively eliminated or controlled at the point of cross-connection.

Hazard, Degree of:

The term is derived from an evaluation of the potential risk to public health and the adverse effect of the hazard upon the potable water system.

a. Hazard, Health

Any condition, device or practice in the water supply system and its operation which could create, or in the judgment of the Panama City Beach Utilities Department, may create a danger to the health and wellbeing of the water customer. An example of a health hazard is a structural defect, including cross-connections, in a water supply system.

b. Hazard, Plumbing

A plumbing type cross-connection in a customer's potable water system that has not been properly protected by a vacuum breaker, air-gap separation or backflow prevention device. Unprotected plumbing type cross-connections are considered to be a health hazard.

c. Hazard, Pollution

An actual or potential threat to the physical properties of the water supply system or to the potability of the public or the customer's potable water system, but which would constitute a nuisance or be aesthetically objectionable or could cause damage to the system or its appurtenances, but would not be dangerous to health.

d. Hazard, System

An actual or potential threat of severe damage to the physical properties of the public potable water supply system or the customer's potable water system or of a pollutant or contaminant which would have a protracted effect on the quality of the potable water in the system.

Industrial Fluids System

Any system containing a fluid or solution which may be chemically, biologically or otherwise contaminated or polluted in a form or approved water supply. This may include, but not be limited to:

Polluted or contaminated waters;

All types of process waters and "used waters" originating from the public potable water system which may have deteriorated in sanitary quality;

Chemicals in fluid form;

Plating acids and alkalis;

Circulated cooling towers that are chemically or biologically treated or stabilized with toxic substances;

Contaminated natural waters such as from wells, springs, rivers, bays, harbors, seas, irrigation canals or systems, etc. Oils, gases, glycerin, paraffins, caustic and acid solutions and other liquids and gaseous fluids in industrial or other purposes; or for firefighting purposes.

Pollution

Means the presence of any foreign substance (organic, inorganic, or biological) in water which

tends to degrade its quality so as to constitute a hazard to impair the usefulness of quality of the water to a degree which does not create an actual hazard to the public health, but which does adversely and unreasonable affect such waters for domestic use.

Public Utility Director/Designated Agent

The Public Utility Director in charge of the Utility Department of the City of Panama City Beach is vested with the authority for the implementation of an effective cross-connection control program and for the enforcement of the provisions of this program. The Utilities Director may assign the enforcement of this program to the agent, or employee of his choice.

Water, Potable

Any water which, according to recognized standards, is safe for human consumption.

Water, Non-Potable

Water which is not safe for human consumption or which is of questionable potability.

Water Purveyor

This term shall mean the owner or operator of the public potable water system supplying an approved water supply to the public. As used herein, the terms water purveyor and Panama City Beach Utilities Department may be used synonymously.

Water, Service Connections

The terminal end of a service connection from the public potable water system, i.e., where the water purveyor loses jurisdiction and sanitary control over the water at its point of delivery to the customer's water system. If a meter is installed at the end of the service connection, then the service connection shall mean the downstream end of the meter. There should be no unprotected takeoffs from the service line ahead of any meter or backflow prevention device located at the point of delivery to the customer's water system. Service connections shall also include water service connections from a fire hydrant and all other emergency or temporary water service connections from the public potable water system.

Water, Used

Any water supplied by a water purveyor from a public potable water system to a customer's water system after it has passed through the point of delivery and is no longer under the sanitary control of the water purveyor.

ITEM 9



CITY OF PANAMA CITY BEACH AGENDA ITEM SUMMARY

1. DEPARTMENT MAKING REQUEST/NAME:

CITY MANAGER / TONY O'ROURKE

2. MEETING DATE:

JULY 23, 2020

3. REQUESTED MOTION/ACTION:

APPROVE RESOLUTION 20-141 ESTABLISHING THE CITY'S ECONOMIC DEVELOPMENT ADVISORY COMMITTEE

4. AGENDA

PRESENTATION
PUBLIC HEARING
CONSENT
REGULAR

5. IS THIS ITEM BUDGETED (IF APPLICABLE)? Yes No

N/A

BUDGET AMENDMENT OR N/A

DETAILED BUDGET AMENDMENT ATTACHED Yes No

N/A

6. BACKGROUND: (WHY IS THE ACTION NECESSARY, WHAT GOAL WILL BE ACHIEVED)

THE CITY COUNCIL HAS PREVIOUSLY DIRECTED STAFF TO CREATE AN ADVISORY COMMITTEE FOCUSED ON FURTHERING THE CITY'S GOALS OF ECONOMIC DEVELOPMENT. RESOLUTION 20-141 ESTABLISHES A COMMITTEE OF 10 PERSONS WITH SET DUTIES AND OBJECTIVES FOCUSED ON IMPROVING THE CITY'S OPPORTUNITY FOR ECONOMIC DEVELOPMENT.

EACH COUNCIL MEMBER SHALL NOMINATE TWO MEMBERS OF THE COMMITTEE. ADDITIONALLY, A REPRESENTATIVE OF THE PANAMA CITY BEACH CHAMBER OF COMMERCE, A REPRESENTATIVE OF THE NORTHWEST FLORIDA BEACHES INTERNATIONAL AIRPORT, AND THE BEACH REPRESENTATIVE OF THE BAY DISTRICT SCHOOL BOARD SHALL SERVE AS EX OFFICIO MEMBERS OF THE BOARD.

THE RESOLUTION PROVIDES FOR SPECIFIC DUTIES AND OBJECTIVES FOR THE COMMITTEE AND PROVIDES THAT THE COMMITTEE SHALL MEET QUARTERLY.

STAFF RECOMMENDS APPROVAL.

RESOLUTION 20-141

A RESOLUTION OF THE CITY OF PANAMA CITY BEACH, FLORIDA, ESTABLISHING AN ECONOMIC DEVELOPMENT ADVISORY COMMITTEE, ITS PURPOSE, MEMBERSHIP, DUTIES AND DURATION.

BE IT RESOLVED by the City Council of the City of Panama City Beach, Florida, that an Economic Development Advisory Committee (“EDAC”) is hereby established.

- A. Mission and Purpose. The purpose of the EDAC shall be to research and recommend economic development efforts that will attract, retain and expand community businesses and create quality, living wage jobs to ensure a diverse economic base, a resilient and growing City tax base and long-term economic vitality for Panama City Beach.
- B. Membership.
 - i. The Committee shall consist of 10 voting members who shall be appointed by the City Council and who shall serve without compensation. Each Councilperson shall nominate two members to the Committee, and one Councilperson shall service as liaison to the Committee. Any interested person shall be eligible to serve on the EDAC.
 - ii. In addition to the foregoing members, a representative of the Panama City Beach Chamber of Commerce, a representative of the Northwest Florida Beaches International Airport, and the Beach representative of the Bay District School Board shall serve as ex officio members of the EDAC. The ex officio members shall not be entitled to vote and shall not be included in the determination of a quorum.
- C. Duties and Objectives. The Committee shall:
 - i. Collaborate with other governmental, non-profit and for-profit organizations in the advancement of economic development and diversification.
 - ii. Recommend policies and programs to retain, expand, incubate and attract businesses to expand and strengthen the local economy.
 - iii. Identify business and industry sectors compatible with Panama City Beach.
 - iv. Review the City's building, zoning and land use regulations to facilitate a transparent, predictable, fair and balanced regulatory environment for business retention and growth, while ensuring protection of the community's health, safety and welfare.
 - v. Identify opportunities to provide a strong first impression and community attractiveness to businesses and visitors.
 - vi. Recommending funding strategies to initiate and support an on-going City Economic Development strategic plan and program.
 - vii. Identify opportunities to facilitate business startups and entrepreneurs.

- viii. No less than annually, the Committee shall make a report to the Council regarding its activities, findings and recommendations.
- D. Meetings. The Committee shall meet at least quarterly.
- E. Duration and Sunset. The Committee shall dissolve on September 30, 2022, unless its duration is extended by Resolution of the City Council.

THIS RESOLUTION shall be effective immediately upon passage.

PASSED in regular session this ____ day of _____, 2020.

CITY OF PANAMA CITY BEACH

By: _____
Mark Sheldon, Mayor

Jo Smith, Interim City Clerk

ITEM 12



City of Panama City Beach

July 23, 2020

TO: Mayor and City Council
FROM: Tony O'Rourke, City Manager
RE: Reorganization Proposal

Based on the Employee Survey results and community feedback, I propose the following reorganization and job reclassifications to better organize around the needs and expectations of our employees and community. These proposed organizational changes are intended to achieve the following goals:

1. Increase the frequency and quality of communications and engagement with employees and community members.
2. Create a Volunteer Program to capitalize on community members' experiences and talents to meet the needs of the City and avoid significant personnel costs.
3. Restructure job duties for strategic and desired organizational, community and fiscal outcomes.

To achieve these goals, we propose the following actions:

- A. Reclassify the part-time (20 hours a week) City Hall receptionist to a 29-hour per week Communications and Volunteer Coordinator. Please see the attached job description. The focus of this reclassified position is three-fold:
 1. Create and manage a citywide volunteer/internship program, with an initial focus on recruiting volunteers for the City Hall part time receptionist position, beach safety education or surveillance spotter program, and code enforcement.
 2. Assist the City's full-time Public Information Officer in promoting and communicating about City programs, policies and projects to both employee and community audiences. Also assist the PIO on social media platforms, community and media relations, website updates and research.
 3. Provides 10 hours per week support to the CRA Manager for media stories, CRA Advisory Committee support, website updates, and public information on CRA projects and status.

The incremental cost for this reclassification is approximately \$10,224. Most of this will be borne by the CRA.

B. Combine the City Clerk/Civil Service Sr. Administrative Support Specialist positions

The prospective City Clerk reclassification will focus on taking responsibility for assisting the Civil Service Board in recruitment responsibilities and administration of the NEOGov online hiring system, as well as the existing duties of the City Clerk. Please see the attached reclassification job description.

Combining these two positions will save the City approximately \$20,000.

In conclusion, these organizational changes will redeploy staff and resources to high priority functions that will better serve both our employees and the community at large.

CITY OF PANAMA CITY BEACH
Job Description

JOB TITLE: Communications and Volunteer Coordinator– Permanent Part-Time

SALARY RANGE: \$12.09 - \$19.34/hr.

SHIFT: Days

LOCATION: City Hall

REPORTS TO: Human Resources

PREPARED BY: Human Resources

APPROVED BY: City Council

PAY GRADE: N/A

DIVISION: Admin

DEPT: Admin

FSLA STATUS: Non-Exempt

POSITION: Permanent Part-Time

DATE:

SUMMARY:

This position serves to support all aspects of City communications, marketing, education, promotion and the volunteer/internship program. The person works closely with the PIO, acting on directive from the PIO. One third of the duties are assigned to the Community Redevelopment Agency (CRA) Director, educating the public about this vital ongoing project. The coordinator will also work in close concert with all members of the Leadership Team, promoting various programs and projects within the City. The position requires initiative and good judgement and an ability to pull out the most important aspects from lengthy meetings and/or information.

ESSENTIAL DUTIES AND RESPONSIBILITIES:

Establishes and manages a citywide volunteer/internship program, with initial focus on recruiting volunteers for City Hall front desk receptionist, beach safety, rip current education, and code enforcement duties such as giving notice to property owners.

- Establishes registration questionnaire
- Recruits volunteers, maintains roster, tracks hours served, schedules
- Hosts volunteer orientation and training program
- Serves as liaison between City staff and volunteers
- Markets volunteer program
- Assigns, monitors and reviews volunteer work

Provides 10 hours per week assistance to CRA Director providing materials, updating website, sitting in on CRA Committee meetings, writing stories, etc.

Assists with the promotion of city program, policies and projects to both internal and external audiences

Develops relationships with area schools, establishing a speaker network of elected officials and staff for various programs

Provides support to police and fire in job recruitment through Arnold High School

Assists with employee newsletter

Plans, researches, develops, writes and edits promotional, educational and informational materials and publications from City departments and/or pertaining to City programs, policies and initiatives.

Updates social media platforms and answers social media questions

Performs website updates

Responds to routing informational inquiries from the public, via telephone, email and social media

Assists the PIO as needed with special events, media, and maintaining brand integrity throughout organization

Serves as the acting PIO during the PIO's absence

Compose correspondence as need by City Manager/Mayor

Handles employee recognition program, orders plaques for 5, 10, 15, 20, etc., -year employees

Provides research for payroll/HR/PIO/City Council, with neighboring municipalities, or others statewide, as requested

Serves as backup for HR on NEOGOV

Provides lobby back-up as needed

Performs other tasks, as assigned

SUPERVISORY RESPONSIBILITIES:

None

COMPETENCIES:

To perform the job successfully, an individual should demonstrate the following competencies:

Technical Skills - Assesses own strengths and weaknesses; Pursues training and development opportunities; Strives to continuously build knowledge and skills; Shares expertise with others.

Customer Service - Manages difficult or emotional customer situations; Responds promptly to customer needs; Solicits customer feedback to improve service; Responds to requests for service and assistance; Meets commitments.

Interpersonal Skills - Focuses on solving conflict, not blaming; Maintains confidentiality; Listens to others without interrupting; Keeps emotions under control; Remains open to others' ideas and tries new things.

Oral Communication - Speaks clearly and persuasively in positive or negative situations; listens and gets clarification; Responds well to questions; Demonstrates group presentation skills; Participates in meetings.

Written Communication - Writes clearly and informatively; Edits work for spelling and grammar; Varies writing style to meet needs; Presents numerical data effectively; Able to read and interpret written information.

Teamwork - Balances team and individual responsibilities; Exhibits objectivity and openness to others' views; Gives and welcomes feedback; Contributes to building a positive team spirit; Puts success of team above own interests; Able to build morale and group commitments to goals and objectives; Supports everyone's efforts to succeed.

Diversity - Demonstrates knowledge of EEO policy; Shows respect and sensitivity for cultural differences; educate others on the value of diversity; promotes a harassment-free environment; Builds a diverse work force.

Ethics - Treats people with respect; Keeps commitments; inspires the trust of others; Works with integrity and ethically; Upholds organizational values.

Organizational Support - Follows policies and procedures; Completes administrative tasks correctly and on time; supports organization's goals and values; Benefits organization through outside activities; Supports affirmative action and respects diversity.

Judgement - Displays willingness to make decisions; Exhibits sound and accurate judgment; Supports and explains reasoning for decisions; Includes appropriate people in decision-making process; Makes timely decisions.

Motivation - Sets and achieves challenging goals; Demonstrates persistence and overcomes obstacles; Measures self against standard of excellence; Takes calculated risks to accomplish goals.

Professionalism - Approaches others in a tactful manner; Reacts well under pressure; Treats others with respect and consideration regardless of their status or position; Accepts responsibility for own actions; Follows through on commitments.

Quality - Demonstrates accuracy and thoroughness; Looks for ways to improve and promote quality; Applies feedback to improve performance; Monitors own work to ensure quality.

Quantity - Meets productivity standards; Completes work in timely manner; Strives to increase productivity; Works quickly.

Safety and Security - Observes safety and security procedures; Determines appropriate action beyond guidelines; Reports potentially unsafe conditions; Uses equipment and materials properly.

Adaptability - Adapts to changes in the work environment; Manages competing demands; Changes approach or method to best fit the situation; Able to deal with frequent change, delays, or unexpected events.

Attendance/Punctuality - Is consistently at work and on time; Ensures work responsibilities are covered when absent; Arrives at meetings and appointments on time.

Dependability - Follows instructions, responds to management direction; Takes responsibility for own actions; Keeps commitments; Commits to long hours of work when necessary to reach goals. Completes tasks on time or notifies appropriate person with an alternate plan.

Initiative - Volunteers readily; Undertakes self-development activities; Seeks increased responsibilities; Takes independent actions and calculated risks; Looks for and takes advantage of opportunities; Asks for and offers help when needed.

Innovation - Displays original thinking and creativity; Meets challenges with resourcefulness; Generates suggestions for improving work; Develops innovative approaches and ideas; Presents ideas and information in a manner that gets others' attention.

QUALIFICATION REQUIREMENTS:

To perform this job successfully, an individual must be able to perform each essential duty satisfactorily. The requirements listed below are representative of the knowledge, skill, and/or ability required. Reasonable accommodations may be made to enable individuals with disabilities to perform the essential functions.

EDUCATION and EXPERIENCE:

High school diploma or general education degree (GED) with business school training desirable. Some experience in clerical work involving typing with average ability. A comparable amount of training or experience may be substituted for the minimum qualifications.

LANGUAGE SKILLS:

Ability to understand and follow oral and/or written instructions; must be able to keep records and make reports.

MATHEMATICAL SKILLS:

Ability to add, subtract, multiply, and divide in all units of measure, using whole numbers, common fractions, and decimals. Ability to compute rate, ratio, and percent and to draw and interpret bar graphs.

REASONING ABILITY:

Ability to apply common sense understanding to carry out instructions furnished in written, oral, or diagram form.

OTHER REQUIREMENTS:

Must have knowledge of standard office and clerical practices and procedures. Must have knowledge and proficiency in the use of standard office machines. Must have knowledge of the legal documents utilized in municipal government and the procedures necessary to process them. Must be able to establish and maintain a good working relationship with City officials, department heads, other City employees and the general public.

Strong communication and people skills required as well as the ability to work well with team members in a professional, fun environment. A sense of humor is essential. Must be able to coordinate many things at once and work under deadline.

Must possess a valid Florida Driver's License - driving record must be acceptable to the City insurance program. Applicants will be administered a general office skills examination and typing test unless they have a college degree. A passing score of 70% must be obtained on the office skills examination.

PHYSICAL DEMANDS:

The physical demands described here are representative of those that must be met by an employee to successfully perform the essential functions of this job. Reasonable accommodations may be made to enable individuals with disabilities to perform the essential functions.

While performing the duties of this job, the employee is regularly required to stand, walk, talk or hear, use hands to finger, handle or feel, stoop, kneel, crouch or crawl, and reach with hands and arms.

The employee must frequently lift and move up to 10 pounds. Specific vision abilities required by this job is ability to adjust focus, close vision and peripheral vision, color vision, and distance vision.

WORK ENVIRONMENT:

The work environment characteristics described here are representative of those an employee encounters while performing the essential functions of this job. Reasonable accommodations may be made to enable individuals with disabilities to perform the essential functions.

While performing the duties of this job, the employee is not subjected to any special or extraordinary environmental conditions, other than those normally found in an office environment. The noise level in the work environment is usually quiet to moderate.

I hereby acknowledge receipt of the job description and certify that I meet the qualification requirements stated herein and I am able to perform the essential duties and responsibilities of this position. I acknowledge that in addition to the duties outlined above I may be required to perform additional duties.

Signature

Date

**CITY OF PANAMA CITY BEACH
Job Description**

JOB TITLE: City Clerk/Civil Service Administrator

SALARY RANGE: \$23.93 - \$39.49

SHIFT: Days

LOCATION: City Hall

REPORTS TO: City Council

PREPARED BY: City Manager

APPROVED BY: City Council

PAY GRADE: 38

DIVISION: Administration

DEPT: Administration

FSLA STATUS: Exempt

POSITION: Permanent Full-Time

DATE:

SUMMARY:

This position is responsible for complex administrative work to oversee the city's record management program and maintain all municipal official records; provide human resource, risk management and contract management support; clerical work in assisting the Civil Service Board; and other duties as assigned. Work is performed under the supervision of City Council and City Manager.

ESSENTIAL DUTIES AND RESPONSIBILITIES:

In addition to the essential duties and responsibilities, other tasks may be assigned:

Serves as ex-officio Clerk of the City Council.

Serves as the official depository for the storage and maintenance of all ordinances, resolutions, motions and documents of the City Council.

Serves as the official custodian of the City seal and of all official records, documents and papers of the City.

Gives notice of City Council meetings as required by law. Will be present for all meetings of the City Council.

Will record the proceedings of the City Council electronically and in a journal which he/she shall maintain for such purpose.

Will establish regulations and procedures for making official city records available to the public.

Implement and maintain the Granicus agenda software system.

Oversees and coordinates responses for public records requests.

Provides administrative support to the City Manager, City Secretary, Civil Service, and Human Resources and Risk Director.

Performs such other duties as they City Council may require.

Civil Service:

Assists the Civil Service Board in maintaining all job applications and administers all examinations prescribed by Board.

Serves as the administrator for the NEOGOV hiring system.

Prepare backup materials for Board meetings; takes notes and records all Board meetings in order to type minutes for the Board's approval

Prepares for job interviews of prospective employees;

Handles daily correspondence; must keep varied clerical records.

Prepare reports and file office records.

Maintains hire dates and advises of end of probation periods.

Advises Human Resources for recognition of milestone dates.

Notifies Commissioners of meetings and maintains minutes for them.

Advertise for positions as directed by City Manager. Posts vacancies as directed on the City website and posts notices to all Departments.

Type letters as instructed (signed by the Chairman when directed).

Coordinates drug testing for potential new employees.

Coordinates annual meeting of employees to include election of a new Commissioner - if more than one nominated, must handle the election.

Must be able to obtain Notary Public certificate within three months.

Will rotate duties on switchboard as relief for receptionist as needed.

Related duties as required.

SUPERVISORY RESPONSIBILITIES:

None

COMPETENCIES:

To perform the job successfully, an individual should demonstrate the following competencies:

Analytical - Synthesizes complex or diverse information; Collects and researches data; Uses intuition and experience to complement data; Designs work flows and procedures.

Problem Solving - Identifies and resolves problems in a timely manner; Gathers and analyzes information skillfully; Develops alternative solutions; Works well in group problem solving situations; Uses reason even when dealing with emotional topics.

Project Management – Develops project plans; coordinates projects; communicates changes and progress; completes projects on time and budget; manages project team activities.

Technical Skills - Assesses own strengths and weaknesses; Pursues training and development opportunities; Strives to continuously build knowledge and skills; Shares expertise with others.

Customer Service - Manages difficult or emotional customer situations; Responds promptly to customer needs; Solicits customer feedback to improve service; Responds to requests for service and assistance; Meets commitments.

Interpersonal Skills - Focuses on solving conflict, not blaming; Maintains confidentiality; Listens to others without interrupting; Keeps emotions under control; Remains open to others' ideas and tries new things.

Oral Communication - Speaks clearly and persuasively in positive or negative situations; listens and gets clarification; Responds well to questions; Demonstrates group presentation skills; Participates in meetings.

Written Communication - Writes clearly and informatively; Edits work for spelling and grammar; Varies writing style to meet needs; Presents numerical data effectively; Able to read and interpret written information.

Teamwork - Balances team and individual responsibilities; Exhibits objectivity and openness to others' views; Gives and welcomes feedback; Contributes to building a positive team spirit; Puts success of team above own interests; Able to build morale and group commitments to goals and objectives; Supports everyone's efforts to succeed.

Visionary Leadership – Displays passion and optimism; inspires respect and trust; mobilizes others to fulfill the vision; provides vision and inspiration to peers and subordinates.

Change Management – Develops workable implementation plans; communicates

changes effectively; builds commitment and overcomes resistance; prepares and supports those affected by change; monitors transition and evaluates results.

Delegation – Delegates work assignments; matches the responsibility to the person; gives authority to work independently; sets expectations and monitors delegated activities; provides recognition for results.

Leadership - Exhibits confidence in self and others; Inspires and motivates others to perform well; effectively influences actions and opinions of others; Accepts feedback from others; Gives appropriate recognition to others.

Managing People – Includes staff in planning, decision-making, facilitating and process improvement; takes responsibility for subordinates activities; makes self available to staff; provides regular performance feedback; develops subordinates' skills and encourages growth; solicits and applies customer feedback (internal and external); fosters quality focus in others; improves processes, products and services; continually works to improve supervisory skills.

Quality Management – Looks for ways to improve and promote quality; demonstrates accuracy and thoroughness.

Diversity - Demonstrates knowledge of EEO policy; Shows respect and sensitivity for cultural differences; educate others on the value of diversity; promotes a harassment-free environment; Builds a diverse work force.

Ethics - Treats people with respect; Keeps commitments; inspires the trust of others; Works with integrity and ethically; Upholds organizational values.

Organizational Support - Follows policies and procedures; Completes administrative tasks correctly and on time; supports organization's goals and values; Benefits organization through outside activities; Supports affirmative action and respects diversity.

Strategic Thinking – Develops strategies to achieve organizational goals; understands organization's strengths and weaknesses; analyzes market and competition; identifies external threats and opportunities; adapts strategy to changing conditions.

Judgement - Displays willingness to make decisions; Exhibits sound and accurate judgment; Supports and explains reasoning for decisions; Includes appropriate people in decision-making process; Makes timely decisions.

Motivation - Sets and achieves challenging goals; Demonstrates persistence and overcomes obstacles; Measures self against standard of excellence; Takes calculated risks to accomplish goals.

Planning/Organizing – Prioritize and plans work activities; uses time efficiently; plans for additional resources; sets goals and objectives; organizes or schedules other people and their tasks; develops realistic action plans.

Professionalism - Approaches others in a tactful manner; Reacts well under pressure; Treats others with respect and consideration regardless of their status or position; Accepts responsibility for own actions; Follows through on commitments.

Quality - Demonstrates accuracy and thoroughness; Looks for ways to improve and promote quality; Applies feedback to improve performance; Monitors own work to ensure quality.

Quantity - Meets productivity standards; Completes work in timely manner; Strives to increase productivity; Works quickly.

Safety and Security - Observes safety and security procedures; Determines appropriate action beyond guidelines; Reports potentially unsafe conditions; Uses equipment and materials properly.

Adaptability - Adapts to changes in the work environment; Manages competing demands; Changes approach or method to best fit the situation; Able to deal with frequent change, delays, or unexpected events.

Attendance/Punctuality - Is consistently at work and on time; Ensures work responsibilities are covered when absent; Arrives at meetings and appointments on time.

Dependability - Follows instructions, responds to management direction; Takes responsibility for own actions; Keeps commitments; Commits to long hours of work when necessary to reach goals. Completes tasks on time or notifies appropriate person with an alternate plan.

Initiative - Volunteers readily; Undertakes self-development activities; Seeks increased responsibilities; Takes independent actions and calculated risks; Looks for and takes advantage of opportunities; Asks for and offers help when needed.

Innovation - Displays original thinking and creativity; Meets challenges with resourcefulness; Generates suggestions for improving work; Develops innovative approaches and ideas; Presents ideas and information in a manner that gets others' attention.

QUALIFICATION REQUIREMENTS:

To perform this job successfully, an individual must be able to perform each essential duty satisfactorily. The requirements listed below are representative of the knowledge, skill, and/or ability required. Reasonable accommodations may be made to enable

individuals with disabilities to perform the essential functions.

EDUCATION and EXPERIENCE:

Qualified candidates will have a bachelor's degree from an accredited college or university with major coursework in Public Administration, Business Administration, or a related field. A Master's Degree is preferred. The best candidates will have seven (7) to nine (9) years progressively responsible administrative support experience.

Knowledge of pertinent federal, state and local ordinances, codes, and regulations related to public records and records management is important. Specific knowledge of Florida law is a plus but by no means required.

Professional certifications, such as a Certified Municipal Clerk (CMC) or Master Municipal Clerk (MMC) are highly desirable.

LANGUAGE SKILLS:

Ability to read and interpret documents. Ability to speak English effectively before groups, as well as one on one. Must remain courteous and professional at all times.

MATHEMATICAL SKILLS:

Ability to add, subtract, multiply, and divide in all units of measure, using whole numbers, common fractions, and decimals. Ability to compute rate, ratio, and percent and to draw and interpret bar graphs.

REASONING ABILITY:

Ability to solve practical problems and deal with a variety of concrete variables in situations where only limited standardization exists. Ability to interpret a variety of instructions furnished in written, oral, diagram, or schedule form.

OTHER REQUIREMENTS:

Must have knowledge of standard office and clerical practices and procedures, as well as knowledge and proficiency in the use of standard office machines, computers (Microsoft Office applications specifically) and calculators. Must have knowledge of the legal documents utilized in municipal government and the procedures necessary to process them; must have comprehensive knowledge of the mechanics and functions of City Government and extensive knowledge of the City Charter.

Must possess valid Florida Driver's License - driving record must be acceptable to the City insurance program. Applicants will be administered applicable tests and typing test.

Must be able to establish and maintain good working relationship with City officials, department heads, other City employees and the general public; must be able to perform illustrative duties and essential eligibility tasks in a manner which is not a direct threat or significant risk to the health or safety of others that cannot be eliminated by a modification of policies, practices or procedures of the City, or by provision of auxiliary

aids. "Direct threat" shall be determined pursuant to 28 CFR, Section 36.208.

PHYSICAL DEMANDS:

The physical demands described here are representative of those that must be met by an employee to successfully perform the essential functions of this job. Reasonable accommodations may be made to enable individuals with disabilities to perform the essential functions.

While performing the duties of this job, the employee is regularly required to sit, stand, walk, talk or hear, use hands to finger, handle or feel, stoop, kneel, crouch or crawl, and reach with hands and arms.

The employee may occasionally lift and move up to 25 pounds. Specific vision abilities required by this job is ability to adjust focus, close vision and peripheral vision, color vision and distance vision. Some specific job duties that require one or more of the physical demands mentioned are typing, filing, moving boxes, typewriters, and tables.

WORK ENVIRONMENT:

The work environment characteristics described here are representative of those an employee encounters while performing the essential functions of this job. Reasonable accommodations may be made to enable individuals with disabilities to perform the essential functions.

While performing the duties of this job, the employee is not subjected to any special or extraordinary environmental conditions, other than those normally found in an office environment. The noise level in the work environment is usually quiet to moderate.

I hereby acknowledge receipt of the job description and certify that I meet the qualification requirements stated herein and I am able to perform the essential duties and responsibilities of this position. I acknowledge that in addition to the duties outlined above I may be required to perform additional duties.

Signature

Date

ITEM 13



CITY OF PANAMA CITY BEACH AGENDA ITEM SUMMARY

1. DEPARTMENT MAKING REQUEST/NAME:

ADMINISTRATION

2. MEETING DATE:

JULY 23, 2020

3. REQUESTED MOTION/ACTION:

CONSIDER REQUEST TO SEEK PROPOSALS FOR DEVELOPMENT OF CITY'S 8 ACRE SITE
ADJACENT TO FRANK BROWN PARK

4. AGENDA

PRESENTATION
PUBLIC HEARING
CONSENT
REGULAR

5. IS THIS ITEM BUDGETED (IF APPLICABLE)? YES NO N/A
BUDGET AMENDMENT OR N/A

DETAILED BUDGET AMENDMENT ATTACHED YES NO N/A

6. BACKGROUND: (WHY IS THE ACTION NECESSARY, WHAT GOAL WILL BE ACHIEVED)

STAFF REQUESTS COUNCIL'S DIRECTION REGARDING ITS DESIRE TO SEEK PROPOSALS
FROM QUALIFIED PERSONS OR FIRMS TO DEVELOP ALL OR A PORTION OF THE CITY'S 8
ACRE SITE LOCATED ADJACENT TO THE ENTRANCE OF FRANK BROWN PARK.

A DRAFT ADVERTISEMENT IS ATTACHED FOR THE COUNCIL'S CONSIDERATION AND
MODIFICATION.

**Request for Proposals
Development of 8-Acre Site
Adjacent to Frank Brown Park Sports Complex**

1.0 Introduction & Overview

Panama City Beach, Florida is one of the state's fastest growing areas. Located along the Gulf of Mexico in Florida's Great Northwest, Panama City Beach is experiencing unprecedented growth. With a population of approximately 14,000 permanent residents and an estimated 25,000 visiting the area daily, the City desires to enhance the quality of services, facilities and experiences for its residents as well as their visitors.

The City of Panama City Beach is soliciting development proposals that will provide uses, amenities or facilities that complement and enhance the experience of visitors to one of the region's recreational treasures, Frank Brown Park Sports Complex and, in addition, Pier Park.

Offering

The City is offering a unique opportunity for development situated adjacent to one of the region's largest and most popular recreation facilities, Frank Brown Park Sports Complex. The development will also lie directly across the street from Pier Park, a public, beachfront park and a private retail/entertainment venue. An approximate 8-acre site currently under City ownership lying adjacent to Frank Brown Park and fronting the Panama City Beach Parkway will be made available by long term ground lease or sale for development by the firm(s) or individual(s) who will be selected based on their qualifications, development concept, presentation, and offer.

It is the desire of the City that the proposed development complement the activities and facilities located at Frank Brown Park Sports Complex and Pier Park, in addition to functioning as a destination, enhancing and improving existing community assets and providing revenue to support the operation of Frank Brown Park Sports Complex. Uses preliminarily discussed by the City include, but are not limited to, entertainment, food and beverage and retail venues.

The intent of the entire selection process is to grant the selected development partner(s) with exclusive development rights for a period of up to one year, subject to the terms of a developer's agreement which will document the developer's concept, timeframe and assurances that the developer's plan will be completed.

1.1 The Site

The approximately 8-acre site is located at the entrance to the City's Frank Brown Park with frontage along the Panama City Beach Parkway (U.S. Highway 98 also known as Back Beach Road), a major four-lane divided highway. U.S. Highways 231 and 331 and S.R.s 77 and 79 provide direct access between U.S. Highway 98 and I-10. U.S. Highway 231, Highway 331, S.R. 77 and S.R. 79 are four-lane facilities.

The parcel it is well drained with a portion of the site being currently used for overflow parking for the Frank Brown Park Sports Complex. A jurisdictional wetland is located north of the proposed development parcel. The proposed development will be required to meet the City's stormwater policy, and will need to include a dedicated stormwater pond on-site that is located and sized by a Florida Registered Professional Engineer. The proposed development will need to follow FEMA's guidelines for floodplain management generally, and

The parcel is bordered by an internal access road providing ingress and egress to Frank Brown Park from North Pier Park Road. This roadway connects to Bay Parkway and S.R. 79, increasing access to the regional sports complex and the subject 8-acre site. The parcel is presently zoned for public use, though interested developers should disregard this limitation in their preparation of proposals, as the City will consider a rezoning of the property if necessary to accommodate the selected development proposal.

The 8-acre site is located at the entrance to Frank Brown Park, a 120-acre recreational complex that provides national and regional level tournament venues. In 2017 (pre-Hurricane Michael and COVID 19), [] individuals visited the Park. In 2021, it is estimated that there will be over [650],000 visitors. Tournaments have included national qualifiers for USSSA Baseball, USFA Fast Pitch Softball and the Softball World Series. Amenities include 9 baseball/softball fields, eight batting cages, a t-ball

field, a specially surfaced Miracle League field, three soccer fields, four multi-purpose football fields, four tennis courts, a tennis wall, two outdoor basketball courts, two shuffle-board courts, three playgrounds for various ages, an imagination playground, one large playground pavilion, two lakeside picnic pavilions, a freshwater youth fishing pond, Gayle's recreational walking and bike trails, three fenced dog parks, a 22 acre festival site, a community center and gymnasium, and an aquatic center featuring a 50 meter heated and cooled Olympic pool with a one meter springboard diving well, a seasonal 5,000 square foot kid's activity pool, and a seasonal obstacle course.

Directly south of Frank Brown Park Sports Complex and the subject parcel is Pier Park, a 266 acre parcel which extends from U.S. 98 to the City's Pier in the Gulf of Mexico. Pier Park is a partially developed family-oriented retail destination containing a mix of shopping, dining and entertainment venues, as well as a bathing beach and sightseeing/fishing pier. Simon Property Group, L.P. and the St. Joe Company are the developers. The western third of Pier Park is a passive low impact, public recreation area known as Aaron Bessant Park, which provides a 70 acre facility including an outdoor amphitheater and stage, several paved walking trails, two large scenic lakes and a Veteran's Memorial. Pier Park also offers 1200 feet of pristine, white gulf beach open to the public with ample, landscaped parking. Pier Park is a primary destination for residents and visitors alike.

2.0 Process for Respondents

The City is seeking proposals from firms and/or individuals interested in developing all or a portion of the +/- 8-acre site. It is the City's intent to solicit specific information from interested firms and individuals that would allow the City to evaluate the capabilities, development concept and the ability of potential developers to implement the project proposed. City staff will screen the submitted proposals and the City Manager will create a recommended shortlist of potential development partners for approval or change by the City Council. Shortlisted partners will be asked to make a presentation to the City Council. It is the intent of the City to select one or more development teams which will be extended exclusive rights of development for a specific period of time for a specific project.

2.1 Proposal Submittal Requirements

Each respondent shall submit the following information for review and consideration by the City.

1. Letter of interest should provide an overview of the development team including organizational structure and past experience. The Letter of Interest should provide a statement of assurance and understanding of the City's intent in the respondent's own words. The Letter of Interest should be signed by a principal of the development team that has the authority to bind the organization.
2. Provide information on the proposed development team including the roles each team member will have, their qualifications and capabilities.
3. Provide examples that demonstrate the development team's experience on previous public-private initiatives and in the implementation of the product type desired by the City.
4. Provide a detailed description of how the development team proposes developing the 8- acre site.
5. Documentation establishing the legal ability of the proposer, together with credible evidence of the availability of funding, to complete the development proposed.

2.2 Number of Response Packages

Each respondent shall submit one (1) original and seven (7) copies of the requested information (RFQ). The copies shall be secured in one package and be labeled to include the name of the responder and the name of the project "RFP for 8-Acre Site".

2.3 Anticipated Schedule

The City has established the following schedule for evaluating development teams and proposals for the +/- 8-acre site. It is imperative that each respondent understands the importance of adhering to this published schedule. Respondents shall assume full responsibility for the timely delivery of their submittals. The City does reserve the right to amend the milestone dates as presented.

Proposals Due	within 60 days of notice
Announce shortlist	within 21 days of submission
Presentations by shortlisted respondents	within 14 days of shortlist notice
Final ranking announcement	within 14 days of presentations
Negotiations begin with #1 ranked team	within 10 days of ranking notice
Detailed financial proposal due	within 14 days of first negotiation meeting
Final negotiation and agreement execution	4-6 months from initiation of process

3.0 Terms

There will be no communication during the RFP process with the City or the City's representatives, other than as provided in section 4.0 and such communication will be exclusively for clarification regarding procedures or development intent.

It is necessary for responding development teams to comply fully with the general terms and conditions outline in this document if they are to be considered. Each respondent should provide a statement in their Letter of Interest attesting that the respondent has read and understands these procedures.

The City has the right to accept or reject all proposals or parts of proposals and to waive any irregularity, omission or error. The City specifically reserves the right to negotiate modifications, corrections, revisions or alternations to any and all proposals or to reject all proposals in the City's sole and absolute discretion.

4.0 Contact Person Regarding Inquiries of this RFP

Inquiries concerning this RFP, whether technical or general in nature, must be addressed in writing to the City's designated contact person who is:

Tony O'Rourke

City Manager
City of Panama City Beach, Florida
17007 Panama City Beach Parkway
Panama City Beach, Florida 32413
850.233.5100

Responses if any will be in writing. The City will attempt to distribute responses to all who have indicated an interest in responding to this RFP, and the City reserves the right to delay opening responses to allow all firms submitting a timely response to receive any supplemental information and re-submit. The City is not responsible for any information, or reliance on same, regarding this RFP and project from a source other than written information provided by the contact person listed above.

ITEM 14*



CITY OF PANAMA CITY BEACH AGENDA ITEM SUMMARY

1. DEPARTMENT MAKING REQUEST/NAME:
CRA/DAVID CAMPBELL

2. MEETING DATE:
JULY 23, 2020

3. REQUESTED MOTION/ACTION:
CONSIDER COMMERCIAL DEVELOPMENT OF A PORTION OF CITY'S SOUTH THOMAS PARKING LOT

4. AGENDA

PRESENTATION
PUBLIC HEARING
CONSENT
REGULAR

5. IS THIS ITEM BUDGETED (IF APPLICABLE)? Yes No N/A
BUDGET AMENDMENT OR N/A

DETAILED BUDGET AMENDMENT ATTACHED Yes No N/A

6. BACKGROUND: (WHY IS THE ACTION NECESSARY, WHAT GOAL WILL BE ACHIEVED)

STAFF REQUESTS COUNCIL'S DIRECTION REGARDING ITS DESIRE TO SEEK PROPOSALS FROM QUALIFIED PERSONS OR FIRMS TO ENTER INTO A PUBLIC PRIVATE PARTNERSHIP TO DEVELOP ALL OR A PORTION OF THE CITY'S PARKING LOT AT RIPLEYS INTO A RETAIL AND PARKING/TRANSIT CENTER.

IF THE COUNCIL IS INTERESTED IN SEEKING PROPOSALS, STAFF NEEDS SPECIFIC DIRECTION ON WHETHER AND HOW THE SITE DEVELOPMENT SHOULD BE LIMITED, SUCH AS WHETHER DESIRED COMMERCIAL DEVELOPMENT SHOULD BE LIMITED TO A SPECIFIC AREA OF THE SITE OR SPECIFIC PERCENTAGE OF THE SITE, TO ACCOMODATE OTHER CITY USES.

A DRAFT REQUEST FOR PROPOSALS IS ATTACHED FOR COUNCIL'S CONSIDERATION AND MODIFICATION. BECAUSE THIS PROPERTY WAS PURCHASED WITH CRA FUNDS FOR CRA PURPOSES, FLORIDA STATUTES DICTATE THE PROCESS BY WHICH THE CITY MAY OFFER USE OF THAT SITE TO THIRD PARTIES.

**REQUEST FOR PROPOSALS
FOR THE DEVELOPMENT OF PROPERTY
LOCATED IN THE FRONT BEACH ROAD
COMMUNITY REDEVELOPMENT AREA**

Notice is hereby given pursuant to Section 163.380, Florida Statutes, that the City of Panama City Beach invites qualified firms or individuals to submit proposals concerning the retail development of a portion of the City's 3.8 acre property located at 9941 Thomas Drive, Panama City Beach, Florida and identified by Bay County Parcel ID No. 34870-000-000 (the "Property"). The Property is located in the Front Beach Road Community Redevelopment Area and is currently being used as a dirt parking lot. The City Council of the City of Panama City Beach serves, ex-officio, as the governing body of the City of Panama City Beach Community Redevelopment Agency.

The City is interested in entering a public private partnership with a qualified developer to develop a portion of the site for retail use via a long term ground lease. It is the desire of the Council and Agency to see the site redeveloped in a manner that complements the City's efforts to advance the Front Beach Road Community Redevelopment Plan. A copy of the City's generalized vision for the Property, the Front Beach Road Community Redevelopment Plan ("CRA Plan"), and any additional information is available for your review at Office of the CRA Manager, at 116 South Arnold Road, Panama City Beach, Florida 32413, and may be provided electronically upon request to dcampbell@pcbqov.com.

All interested persons are invited to make proposals for the retail development of the Property. The City will consider all proposals received and the legal and financial ability of the persons making such proposals to carry them out. Any party interested in purchasing the Property for the purposes of redevelopment is hereby notified that sealed proposals to develop such property must be received in the City Manager's Office at 110 South Arnold Road, Panama City Beach, Florida 32413 by 10:00 a.m. on [], 2020. Proposals received after that date will not be considered. Any such offer must include a description of the proposed development that would be built on the Property and documentation establishing the legal ability of the proposer, together with credible evidence of the availability of funding to complete the development proposed. The City may accept such proposals as it deems to be in the public interest and in furtherance of Chapter 163, Part III, Florida Statutes.

The lease of the Property shall be conveyed at a value and under such terms and conditions (including covenants), determined to be in the public interest for uses in accordance with the CRA Plan and in accordance with such reasonable procedures as the City and the CRA may prescribe. In determining the value upon which the Property will be conveyed, the City will take into account and give consideration to: (a) the long-term benefits to be achieved by the CRA and the City based on the proposed use when compared to any potential short-term losses or costs in the disposal of such real property;

(b) the appraised value; (c) the uses provided for in the CRA Plan; (d) the restrictions upon the property, and any covenants, conditions, and the obligations assumed by the purchaser/developer of the property; and (e) the objectives of the CRA Plan for the prevention of the recurrence of slum or blighted areas.

The City Council of the City of Panama City Beach, Florida, will consider the proposed development of the Property at its regularly scheduled meeting to be held at 6:00 PM on Thursday, [], 2020, in Council Chambers, at City Hall, 17007 Panama City Beach Parkway, Panama City Beach, Florida 32413.

Any appeal of the City Council's decision may be made to the Clerk of the Circuit Court in Bay County, Florida. If a person decides to appeal any decision made by the City Council with respect to any matter considered, such person will need a record of the proceedings and may need to ensure that a verbatim record is made, including the testimony and evidence upon which the appeal is to be made.

Any person requiring a special accommodation to participate in this proceeding because of a disability or physical impairment should contact the City Clerk, at City Hall, 17007 Panama City Beach Parkway, Panama City Beach, Florida, 32413 or by phone at (850) 233-5100 at least five (5) calendar days prior to the meeting. If you are hearing or speech impaired, and you possess TDD equipment, you may contact the City Clerk using the Florida Dual Party Relay system which can be reached at (800) 955-8770 (Voice) or (800) 955-8771 (TDD).

CITY OF PANAMA CITY BEACH, FL

BY:/S/ TONY O'ROURKE, CITY MANAGER