

PCB24-12 ITB LANDSCAPING MAINTENANCE SERVICES
CITY MAIN CAMPUS FY2024



**INVITATION TO BID
PCB24-12 ITB LANDSCAPING MAINTENANCE SERVICES
CITY MAIN CAMPUS**

CITY OF PANAMA CITY BEACH
17007 PANAMA CITY BEACH PARKWAY
PANAMA CITY BEACH, FLORIDA 32413

**Date of Issue: December 21, 2023
Responses Due: January 12, 2024**

PCB24-12 ITB LANDSCAPING MAINTENANCE SERVICES
CITY MAIN CAMPUS FY2024

TABLE OF CONTENTS

BIDDING AND CONTRACT DOCUMENT SECTIONS

SECTION PAGES

Invitation to Bid	1 – 2
Information for Bidders	1 – 2
Terms and Conditions	1 – 6
Scope of Work/Specifications	1 – 8
Bid Proposal Form	1 – 5
Reference Form	1

REQUIRED FORMS

SECTION PAGES

Conflict of Interest Statement	1
Drug Free Workplace	1
E-Verify Form	1
Non-Collusion Affidavit	1
Statement on Public Entity Crimes	1 – 3
W9	1 – 6
Insurance Requirements	

INFORMATIONAL EXHIBITS

Notice of Award	
Agreement	
Service Area Maps – Exhibits A - C	

PCB24-12 ITB LANDSCAPING MAINTENANCE SERVICES
CITY MAIN CAMPUS FY2024

INVITATION TO BID

PCB24-12 ITB LANDSCAPE MAINTENANCE SERVICES CITY MAIN CAMPUS FY2024

The City of Panama City Beach is accepting electronic (e-submission) and sealed Bids from qualified contractors to provide landscaping maintenance services to the City of Panama City Beach's Main Campus and the newest fire station located at 11911 Hutchison Blvd which is currently under construction. The Contractor shall provide all materials, equipment and labor to complete the project.

The bid must conform to Section 287.133(3) Florida Statutes, with respect to Public Entity Crimes.

All Bids must be received no later than **Friday, January 12th, 2024, at 9:00AM CDT** at which time all Bids will be publicly opened and read.

Bid documents may be downloaded online at www.demandstar.com and on the City's website at <https://www.pcbfl.gov/about-us/rfp-posts-list> starting on **Thursday, December 21st, 2023**.

- Electronic Bids will only be accepted when submitted through DemandStar's Bid portal. Emailed submissions will not be accepted.
- Alternatively, one original and one electronic copy (USB flash drive preferred) may be delivered to the City Hall Office at the address below. Any sealed Bid submitted on paper must identify and clearly mark the Bid # **PCB24-12 LANDSCAPE MAINTENANCE SERVICES CITY MAIN CAMPUS FY2024** on the package. Bidder's name and return address should be clearly identified on the outside of the package. Receipt of a Bid by any Panama City Beach Office, receptionist, or personnel other than the City Hall's front desk does not constitute "receipt" as required by this solicitation. The City will not be responsible for mail delays, late or incorrect deliveries. The time/date stamp in the City Hall or on DemandStar will be the official authority for determining late Bids.

All paper Bids shall be sealed and delivered or mailed to:

**City of Panama City Beach City Hall
ATTN: Purchasing Manager
17007 Panama City Beach Parkway
Panama City Beach, Florida 32413**

The City reserves the right to accept or reject any or all Bids (in whole or in part) with or without cause and to waive technicalities, irregularities, or informalities.

BIDDERS must submit all questions, if any, in writing at least seven (7) days prior to the BID date. If necessary, questions will be answered as ADDENDA and will be issued to the Contract Documents and posted on the City's website. It is the sole responsibility of the bidder to determine if any addenda have been issued. The due date for questions will be **4:00PM CDT on Friday, January 5th, 2024**.

Any and all questions regarding the Bidding documents shall be directed to the City of Panama City Beach Purchasing Manager: **Carrie Jagers via email: purchasing@pcbfl.gov**. Contact with any other City official or City employees for the purpose of inquiries regarding this Bid or the meaning or interpretation of these specifications shall be grounds for disqualification.

PCB24-12 ITB LANDSCAPING MAINTENANCE SERVICES
CITY MAIN CAMPUS FY2024

For more information on the City's purchasing policies and procedures, or to review the City's Procurement Manual, please visit the City's website at www.pcbfl.gov.

PCB24-12 ITB LANDSCAPE MAINTENANCE SERVICES
CITY MAIN CAMPUS FY2024

INFORMATION FOR BIDDERS

It is the intention of this Invitation to Bid (ITB) to award a contract to provide landscaping maintenance service to the City of Panama City Beach's Main Campus and the newest fire station located at 11911 Hutchison Blvd, which is currently under construction. The Contractor shall provide all materials, equipment, and labor to complete the project.

Potential bidders to the solicitation are expected to review all materials contained herein and prepare responses accordingly.

SOLICITATION TIMELINE:

EVENT	TIME	DATE
Solicitation Release Date	8:00AM CDT	December 21, 2023
Questions from Bidders to warrant a response/Addendum	4:00PM CDT	January 5, 2024
Bids Received By – Deadline & Opening	9:00AM CDT	January 12, 2024
Evaluation Committee Meeting (if applicable)	N/A	N/A
Estimated Notice of Award Date	XXX	January 26, 2024
Estimated City Council Review & Action	9:00AM CDT	January 25, 2024

Bidders submitting paper Bids must submit two (2) complete Bid responses (one (1) original and one (1) digital copy (USB) which must include all the required documentation:

A complete BID response shall consist of the following required documents:

1. Bid Proposal Form
2. Reference Form
3. Drug Free Workplace
4. Public Entity Crime Statement
5. E-Verify Form
6. Non-Collusion Affidavit
7. Conflict of Interest
8. W9
9. Acknowledged Insurance Requirements

Additional reference documents:

1. Notice of Award
2. Agreement
3. Exhibit A - Main City Campus Map

PCB24-12 ITB LANDSCAPE MAINTENANCE SERVICES
CITY MAIN CAMPUS FY2024

4. Exhibit B – Landscape Plan for Fire Station #31 & Police/Fire Storage
5. Exhibit C – Landscape Plan for Fire Station #32

BIDDERS must satisfy themselves with the accuracy of any estimated quantities and a review of the scope of work and specifications including any ADDENDA. After the BIDS have been submitted, the BIDDER shall not assert that there was a misunderstanding concerning the quantities of WORK or of the nature of the WORK to be done.

Submittal of a Bid in response to this Invitation for Bid constitutes an offer by the Bidder. Bids which do not comply with these requirements may be rejected at the option of the City. It is the Bidder's responsibility to ensure that Bid submittals are in accordance with any addenda(s) issued. Bids not submitted with all the required documents may be rejected.

Failure to comply with the solicitation requirements, specifications, terms and conditions, including those specifying information that must be submitted with a response, may be grounds for rejecting a bid or response.

The City shall award the contract to the lowest fully responsive and responsible Bidder(s); provided, that the City may award the contract to a Bidder(s) other than the lowest Bidder should it find the lowest Bidder does not offer the reliability, quality of service or product afforded by such other Bidder. Where a Bid other than the lowest Bid is taken, the City shall state the reasons upon which such award was made.

The City reserves the right to accept or reject any or all Bids (in whole or in part) with or without cause, to waive any technicalities, irregularities, or formalities, or to accept the Bid(s) which in its judgement best serves The City of Panama City Beach.

[REMAINDER OF THIS PAGE INTENTIONALLY LEFT BLANK.]

PCB24-12 ITB LANDSCAPING MAINTENANCE SERVICES
CITY MAIN CAMPUS FY2024

TERMS AND CONDITIONS

ADDENDUM: If it becomes necessary to revise or amend any part of this Invitation for Bid, the City's Purchasing Manager will furnish the revision by written Addendum through the City's solicitation hosting platform at www.demandstar.com. Addenda information will also be posted online at the City of Panama City Beach website: <https://www.pcbfl.gov>. Bidders are solely responsible to ensure they have received all addenda(s) prior to submitting their Bid.

ANTI-DISCRIMINATION: The Bidder certifies compliance with the non-discrimination clause contained in Section 202. Executive Order 11246, as amended by Executive Order 11375, relative to equal employment opportunity for all persons without regard to race, color, religion, sex, or national origin.

AWARD: The City shall award the contract to the lowest fully responsive and responsible Bidder(s); provided, that the City may award the contract to a Bidder(s) other than the lowest Bidder should it find the lowest Bidder(s) does not offer the reliability, quality of service or product afforded by such other Bidder(s).

BIDDER ACKNOWLEDGEMENT: By submitting a Bid, the Bidder certifies and or acknowledges that he/she has full knowledge of the scope, nature, quality of product to be provided, and/or quality of work to be performed.

Submission of a Bid indicates acceptance by the individual or vendor of the conditions contained in this invitation to Bid, unless clearly and specifically noted in the Bid submitted and confirmed in the contract between the City of Panama City Beach and the individual or vendor selected.

BIDDER EXPENSES: The City is not responsible for any expenses that a Bidder may incur in preparing and submitting Bids called for in this request. The City will not pay for any out-of-pocket expenses, such as word processing, photocopying, postage, per diem, travel expenses and the like, incurred by the Bidder. The City will not be liable for any costs incurred by the Bidder in connection with any interviews/presentations (i.e., travel, accommodations, etc.).

CHANGE ORDER: No out-of-scope services shall be performed in the absence of prior written authorization in the form of a written supplemental agreement and issuance of an appropriate amendment to the contract.

CONE OF SILENCE: The City observes a cone of silence and policies for ethical and professional behavior on all advertised solicitations. Potential bidders and their agents must not communicate in any way with the City Council, City Manager, or any City Staff other than the Purchasing Manager in reference to or relation to this solicitation. This restriction is effective from the time of bid advertisement until an award is made by the City Council. Such communication may result in disqualification.

CONFLICT OF INTEREST: The award of any Contract hereunder is subject to the provision of Chapter 112, Florida Statutes. Bidders must disclose with their Bid the name of any officer, director, partner, proprietor, associate, or agent which is also an officer or employee of the City or of its boards or committees. Bidders must disclose the name of any officer or employee of the City who owns, directly or indirectly, an interest of five percent (5%) or more in the Bidder's organization or any of its branches or affiliate companies.

PCB24-12 ITB LANDSCAPING MAINTENANCE SERVICES
CITY MAIN CAMPUS FY2024

DEFAULT/FAILURE TO PERFORM: The City of Panama City Beach shall be the sole judge of nonperformance, which shall include any failure on the part of the successful Bidder to accept the award, to furnish required documents, and/or fulfill any portion of this contract within the time stipulated. Upon default by the successful Bidder to meet any terms of this agreement, the Purchasing Division will provide the Bidder three (3) days notice (weekends and holidays excluded) to remedy the default. Failure on the Bidder's part to correct the default within the required three (3) days shall result in the contract being terminated, upon the Purchasing Manager notifying in writing the Bidder of its intentions and the effective date of the termination. The following shall constitute default: The City of Panama City beach may terminate the Contract if the Bidder fails to (1) deliver the product within the time specified in the Contract or any extension, (2) maintain adequate progress, thus endangering performance of the Contract, (3) honor any term of the Contract, or (4) abide by any statutory, regulatory, or licensing requirement.

DEVIATION FROM SPECIFICATION: Any deviation from specifications must be clearly stated, explained in detail, and accepted by the City Manager in writing. Otherwise, items offered are expected to be in strict compliance with specifications and the successful Bidder shall be held accordingly.

DOING BUSINESS WITH THE CITY. When a vendor is awarded a contract with the City, the City will request a copy of the vendor's completed W-9 to register the vendor in the City's financial system for invoice processing and payment. Vendors may choose ACH or virtual card for payments, as these forms of payment result in quicker payment of invoices.

E-VERIFY: The awarded Bidder becomes obligated to comply with the provisions of Section 448.095, Fla. Stat., "Employment Eligibility", as amended from time to time. This includes but is not limited to utilization of the E-Verify System to verify the work authorization status of all employees hired after January 1, 2021, and requiring all sub-Bidders to provide an affidavit attesting that the sub-Bidder does not employ, contract with, or subcontract with, an unauthorized alien. The Bidder shall maintain a copy of such affidavit for the duration of the contract. Failure to comply will lead to termination of this Contract, or if a sub-Bidder knowingly violates the statute, the subcontract must be terminated immediately. Any challenge to termination under this provision must be filed in the Circuit Court no later than twenty (20) calendar days after the date of termination. If this contract is terminated for a violation of the statute by the Bidder, the Bidder may not be eligible for or awarded a public contract for a period of one (1) year after the date of termination.

FORCE MAJEURE: Neither the City nor the Bidder shall be liable for its failure to perform hereunder due to contingencies beyond its reasonable control, including but not limited to wars, acts of God, acts of terror, labor disputes, flood, windstorm, explosion, riots, sabotage, and fire and pandemic, provided that prompt notice of such delay is given to the other party. The time for performance shall be extended for a period equal to the duration of the Force Majeure.

INDEMNIFICATION: Regardless of the coverage provided by any insurance, the successful Bidder shall indemnify, save harmless and defend the City, its agents, servants, or employees from and against any and all claims, liability, losses and/or causes of action which may arise from any negligent act or omission of the successful Bidder, its sub-Bidders, agents, servants or employees during the course of performing services or caused by the goods provided pursuant to these Bid documents and/or resultant contract.

PCB24-12 ITB LANDSCAPING MAINTENANCE SERVICES
CITY MAIN CAMPUS FY2024

If any third-party claim is made against the City that, if sustained, would give rise to indemnification liability of the Bidder under this Agreement, the City shall promptly cause notice of the claim to be delivered to the successful Bidder and shall afford the Bidder and its counsel, at the Bidder's sole expense, the opportunity to join in defending or compromising the claim.

INSURANCE: Bidder shall at its expense maintain in force during the Term the insurance on policies and insurers acceptable to the City as required by the City's Insurance Requirements attached hereto as Exhibit "A".

Within thirty (30) days of the date of the Award, and thereafter upon the written request of the City, Bidder shall furnish to the City such certificates of coverage and certified copies of policies pursuant to the City's Insurance Requirements. In order to satisfy this provision, the documentation required by this part must be sent to the following address: ATTN: Risk Management Director, 17007 Panama City Beach Parkway, Panama City Beach, Florida 32413.

INTERPRETATIONS: Any questions concerning conditions and specifications shall be directed to the Purchasing Manager. Interpretations that may affect the eventual outcome of this Bid will be furnished in writing to all prospective Bidders. No interpretation shall be considered binding unless provided in writing by the City of Panama City Beach.

MINOR IRREGULARITIES/INFORMALITIES: The City of Panama City Beach reserves the right to both waive any irregularities or informalities in Bids and to determine, in its sole discretion, whether or not informality is minor.

NON-COLLUSION: The Bidder certifies that this Bid has not been arrived at collusively or otherwise in violation of federal, state, or local laws. Bidder shall certify that this offer is made without prior understanding, agreement, or connection with any corporation, firm or person submitting an offer for the same materials, services, supplies or equipment and is in all respects fair and without collusion or fraud.

No premiums, rebates or gratuities are permitted, either with, prior to or after any delivery of material or provision of services. Any violation of this provision may result in the Contract cancellation, return of materials or discontinuation of services.

NOTIFICATIONS: The City of Panama City Beach's official website for notices, Bids, addendums, and other documents is located at <https://www.pcbfl.gov>. Bidders are also advised that www.demandstar.com is one of the City's sourcing methods of notices, addendums, Bids, and other documented communications for the procurement process. The City is not under any obligation and does not guarantee that Bidders will receive email notifications concerning the posting, amendment or close of solicitations. Bidders are responsible for checking www.demandstar.com or <https://www.pcbfl.gov> for information and updates concerning solicitations or contact the Purchasing Manager.

OPTIONAL CONTRACT USAGE BY OTHER GOVERNMENTAL AGENCIES: All Bidders submitting a response to this Invitation to Bid agree that such response also constitutes a proposal to other Florida governments under the same conditions, for the same contract price, and for the same effective period, should the Bidder feel it is in their best interest to do so.

PAYMENT: Upon acceptance of work by the City, the City shall make payment to the Bidder in accordance with the Local Government Prompt Payment Act, Chapter 218, Florida Statutes. The City reserves the right, with justification, to partially pay any invoice submitted by the Bidder when

PCB24-12 ITB LANDSCAPING MAINTENANCE SERVICES
CITY MAIN CAMPUS FY2024

requested to do so by the City's Department Representative. All invoices shall be directed to Accounts Payable, City of Panama City Beach. Payment for invoices will be made via ACH or Virtual Credit Card only.

PURCHASING POLICIES. For more information on the City's purchasing policies and procedures, or to review the City's Procurement Manual, please visit the City's website at www.pcbfl.gov.

PUBLIC ENTITY CRIMES: By submission of response to the City's Invitation to Bid, Bidder acknowledges and agrees to the following: A person or affiliate who has been placed on the Convicted Vendor List following a conviction for a public entity crime may not submit a Bid on a contract to provide any goods or services to a public entity, may not submit a Bid on a contract with a public entity for the construction or repair of a public building or public work, may not submit Bids for leases of real property to a public entity, may not be awarded or perform work as a Successful Bidder, contractor, supplier, sub-Bidder, or consultant under a contract with any public entity, and may not transact business with any public entity in excess of the threshold amount provided in Section 287-017 Florida Statutes, for CATEGORY TWO for a period of 36 months from the date of being placed on the Convicted Vendor List (Section 287.133, Florida Statutes).

PUBLIC RECORDS: Certain exemptions to the public records law are statutorily provided for in Section 119.07, Florida Statutes. If the Bidder believes any of the information contained in his or her response is exempt from disclosure, then the Bidder must in her or her response specifically identify the material which is deemed to be exempt and cite the legal authority for the exemption. Otherwise, the City will treat all materials received as public records once that information is determined to be available for public inspection.

If the City rejects all Bids or replies submitted in response to a competitive solicitation and the City concurrently provides notice of its intent to reissue the competitive solicitation, the rejected Bid or replies remain exempt from Section 119.07(1) and Section 24(a) of the State Constitution until such time as the City provides notice of an intended decision concerning the reissued competitive solicitation, or until the City withdraws the reissued competitive solicitation. A Bid, proposal, or reply is not exempt for longer than 12 months after the initial agency notice rejecting all Bids, or replies.

The City is a public agency subject to Chapter 119, Florida Statutes. The Bidder shall comply with Florida's Public Records law. Specifically, the Bidder, shall:

- a. Keep and maintain public records required by the public agency to perform the service.
- b. Upon request from the public agency's custodian of public records, provide the public agency with a copy of the requested records or allow the records to be inspected or copied within a reasonable time at a cost that does not exceed the cost provided in this chapter or otherwise provided by law.
- c. Ensure that public records that are exempt or confidential and exempt from public records disclosure requirements are not disclosed except as authorized by law for the duration of the contract term and following completion of the contract if the Bidder does not transfer the records to the public agency.
- d. Upon completion of the contract, transfer, at no cost, to the public agency all public records in possession of the Bidder or keep and maintain public records required by the public agency to perform the service. If the Bidder transfers all public records to the public

PCB24-12 ITB LANDSCAPING MAINTENANCE SERVICES
CITY MAIN CAMPUS FY2024

agency upon completion of the contract, the Bidder shall destroy any duplicate public records that are exempt or confidential and exempt from public records disclosure requirements. If the Bidder keeps and maintains public records upon completion of the contract, the Bidder shall meet all applicable requirements for retaining public records. All records stored electronically must be provided to the public agency, upon request from the public agency's custodian of public records, in a format that is compatible with the information technology systems of the public agency.

The failure of the Bidder to comply with the provisions set forth in this section shall constitute a material breach of Agreement and shall be cause for immediate termination of the Agreement.

If the Bidder has questions regarding the application of Chapter 119 Florida Statutes, to the Bidder's duty to provide public records relating to this contract, contact the custodian of public records at the City of Panama City Beach City Clerk, 17007 Panama City Beach Parkway, Panama City Beach, Florida 32413; 850-233-5100 or CityClerk@pcbfl.gov .

REQUEST FOR ADDITIONAL INFORMATION/CLARIFICATION: The Bidder shall furnish such additional information/clarification as the City may reasonably require. This includes but is not limited to information that indicates Bidder financial resources as well as the ability to provide and maintain the goods or services requested.

RESPONSIBLE VENDOR DETERMINATION: Respondent is here notified that Section 287.05701, Florida Statutes, requires that the City may not request documentation of or consider a vendor's social, political, or ideological interests when determining if the vendor is a responsible vendor.

RIGHT TO REJECT: Bidders are expected to examine the specifications, delivery schedules, Bid prices and extensions and all instructions pertaining to supplies and services. Failure to do so will be at the Bidder's risk. Only the City of Panama City Beach reserves the right to reject all Bids, or any part of any Bid deemed necessary for the best interest of the City. The City may reject any response not submitted in the manner specified by the solicitation documents.

If Bidder purports to add terms or conditions to its Bid, takes exception to any provisions of the Bidding Documents, or attempts to alter the contents of the Contract Documents for the purposes of the Bid, whether in the Bid itself or in a separate communication to the City, then the City will reject the bid as nonresponsive.

RECOMMENDATION OF AWARD INFORMATION: Notice of Award, Bids currently available, and Tabulation sheets will be available online at www.demandstar.com. Bidders who do not have Internet access may request a copy of the tabulation by contacting the Purchasing Manager. (NOTE: information will be provided in accordance with the requirements contained in the section above regarding PUBLIC RECORDS).

RESPONSIBLE BIDDER: A Bidder, business entity or individual who submits a Bid and who has furnished, when required, information and data to prove that its financial resources, production or service facilities, personnel, service reputation and experience are adequate and fully capable to make satisfactory delivery of the goods or services described in the Bid. The City may review vendor performance on City Contracts, and other public entity contracts, in arriving at a

PCB24-12 ITB LANDSCAPING MAINTENANCE SERVICES
CITY MAIN CAMPUS FY2024

determination as to whether a Bidder meets the definition of a responsible vendor who may be recommended for award.

RESPONSIVE BIDDER: A Bidder, business entity or individual who has submitted a Bid or Bid that fully conforms in all material respects to the Invitation to Bid and all of its requirements, including all form and substance.

TAX EXEMPTIONS: The City of Panama City beach is tax exempt. The City of Panama City Beach's tax-exempt number is 85-8012646361C-4.

TIME FOR CONSIDERATIONS: Bids will be irrevocable after the time and date set for the opening of Bids and for a period of sixty (60) days thereafter.

[REMAINDER OF THIS PAGE INTENTIONALLY LEFT BLANK.]

PCB24-12 ITB LANDSCAPING MAINTENANCE SERVICES
CITY MAIN CAMPUS FY2024

SCOPE OF WORK/SPECIFICATIONS

GENERAL INFORMATION

The purpose of this bid is to secure landscaping maintenance services for the City of Panama City Beach's Main Campus and new fire station (under construction at 11911 Hutchison Blvd). The City is seeking a qualified contractor who shall provide all the materials, equipment, and labor required.

Each bidder shall become fully informed as to the extent of services required prior to submitting a bid. No consideration will be granted for any alleged misunderstanding of the work to be done, and it is understood that the submission of a bid is an agreement with all the items and conditions referred to herein.

LOCATION OF WORK:

All work will be conducted on the City of Panama City Beach Main Campus surrounding the City Hall Annex building. Reference Exhibits A & B (Map and Plans). Location details are listed below:

1. **City Hall Annex** – Located at 17007 Panama City Beach Pkwy. This includes the walled courtyard/patio on the west side of the building outside of the council chambers and the outdoor enclosed mechanical area on the southwest corner of the building)
2. **Public Services Administration Building:** Located at 116 South Arnold Road.
3. **Plaza:** Located between the Police Station and the Tourist Development Council Building.
4. **Panama City Beach Police Department:** Located at 17115 Panama City Beach Pkwy.
5. **Panama City Beach Fire Department Station #31:** Located on Campus at 17121 Panama City Beach Parkway. This includes both small stormwater ponds adjacent to the building. ***This location is currently under construction with an estimated completion date of July 15, 2024. Please see Exhibit A for the location and Exhibit B for the Landscape plans. All bids should be based on maintenance for what is shown in the approved landscape plans. Service Charges shall not be issued until after construction is complete and is accepted by the City. The winning contractor will be notified in writing when services in this section are to begin.**
6. **Fuel Barn:** Located to the south of the Fire Department off San Vicente Street.
7. **Police and Fire Storage:** Located on the City Main Campus at 111 San Vicente Street between the Fire Station #31 and the Police Impound Lot. ***This location is currently under construction with an estimated completion date of July 15, 2024. Please see Exhibit A for the location and Exhibit B for the Landscape plans. All bids should be based on maintenance for what is shown in the approved landscape plans. Service Charges shall not be issued until after construction is complete and is accepted by the City. The winning contractor will be notified in writing when services in this section are to begin.**
8. **Police Department Impound Lot:** Located to the south of the Fuel Barn on the southwest corner of the campus at the intersection of Firenzo Ave and San Vicente Street.

PCB24-12 ITB LANDSCAPING MAINTENANCE SERVICES
CITY MAIN CAMPUS FY2024

9. **Storm Water Pond #1:** Located on the south-central side of the campus. Running from the driveway access from Firenzo Avenue to the Plaza.
10. **Panama City Beach Fire Department Station #32 (Reference Exhibit C):** Located at 11911 Hutchison Blvd. ***This location is currently under construction with an estimated completion date of November 15, 2024. Please see Exhibit C for the location and the Landscape plans. All bids should be based on maintenance for what is shown in the approved landscape plans. Service Charges shall not be issued until after construction is complete and is accepted by the City. The winning contractor will be notified in writing when services in this section are to begin.**

This contract does not include services for the Panama City Beach Tourist Information Center. This landscaping is maintained under a separate Tourist Development Council (TDC) contract.

SPECIFICATIONS

GENERAL:

The work to be performed and the terms and conditions of performance of such work and payment therefore by the City of Panama City Beach shall be materially as described in the form of the **Landscape Maintenance Agreement**. The agreement shall be for a term of two (2) years, beginning **February 1, 2024**. The City of Panama City Beach will reserve the right to extend the Agreement upon the same terms and conditions for two (2) additional one (1) year extensions.

THIS WORK DOES NOT INCLUDE Tourist Development Council Building & surrounding landscape shown on Exhibit A located at 17001 Panama City Beach Pkwy, or any of the other City owned and maintained properties not mentioned above.

The proposed specifications below will cover, but not be limited to, the following:

- A. The CONTRACTOR shall furnish all labor, materials, equipment, tools, services and incidentals to complete all work required by this scope of work, except such items the Owner specifically agrees in the Contract to supply or furnish to or for the use of Contractor. Any equipment materials or services not specifically described in the Contract Documents, which may be fairly implied as required thereby or necessary to complete the Work for the use intended shall be within the scope of the Contractor's Work hereunder. All Work shall be performed by trained, properly supervised personnel in accordance with accepted horticultural and safe practices including compliance with all maintenance of traffic standards and procedures.
- B. The CONTRACTOR shall follow accepted horticultural practices to keep the areas to be landscaped attractive and clean in appearance and maintain all plants and turf in a healthy, vigorous condition. All work shall be performed in a professional manner, using quality equipment, methods and materials, all of which must be maintained and operated to the highest industry standards. The workers shall be neat in appearance, wear a uniform which identifies the contractor, and perform their work in a professional manner.
- C. The CONTRACTOR shall assume responsibility for the proper maintenance, survival and

**PCB24-12 ITB LANDSCAPING MAINTENANCE SERVICES
CITY MAIN CAMPUS FY2024**

condition of all plants, turf and irrigation components for the period of this contract.

- D. **GRASS CUTTING:** Prior to mowing, any debris or litter in grass or planting areas shall be removed and legally disposed offsite, in accordance with all applicable laws, rules and regulations. Grass shall be cut at a bench height of three inches. The Contractor shall employ mowing equipment direction patterns to permit recycling of clippings where possible to present a neat appearance. Mowers shall have sharp cutting edges; uneven cutting, plowing, or gouging of the soil shall not be permitted. Cuttings shall be legally disposed of offsite, in accordance with all applicable laws, rules and regulations. Dependent on weather, growing conditions and/or special events, mowing frequency may be adjusted with the total not to exceed 42 mows per year. Hand cutting around guard rails, back flow preventers, head walls, fire plugs, trees, large shrubs, and the like are part of the mowing process. It is the responsibility of the CONTRACTOR to mow the contract areas on a cycle as noted in the chart below. The frequency will be as follows with the tentative dates for the first year of service as follows:

MONTHS	FREQUENCY	DATES	TOTAL
OCTOBER	Weekly	2024- 7, 14, 21, 28	4
NOVEMBER	Biweekly	2024- 11, 25	2
DECEMBER	Biweekly	2024- 9, 23	2
JANUARY	Biweekly	2025- 6, 20	2
FEBRUARY	Biweekly	2024- 5, 19	2
MARCH	Weekly	2024- 4, 11, 18, 25	4
APRIL	Weekly	2024- 8, 15, 22, 29	4
MAY	Weekly	2024- 6, 13, 20, 27	4
JUNE	Weekly	2024- 3, 10, 17, 24	4
JULY	Weekly	2024- 1, 8, 15, 22, 29	5
AUGUST	Weekly	2024- 5, 12, 19, 26	4
SEPTEMBER	Weekly	2024- 2, 9, 16, 23, 30	5
			42

- E. **EDGING AND TRIMMING:** The use of herbicides shall not be allowed for the purpose of eliminating or reducing normal mechanical edging along paved edges.

Mechanically edge all planting beds that are adjacent to turf areas at every mowing cycle. All concrete walks and curbing (if applicable) shall be edged as required to maintain a neat appearance. In addition, whenever mowing, the Contractor shall closely trim around all trees, guys, planting areas, structures, etc. utilizing a “weed eater” type device. Trimming

PCB24-12 ITB LANDSCAPING MAINTENANCE SERVICES
CITY MAIN CAMPUS FY2024

shall be at a height of three inches so that grass is not destroyed. The Contractor will be responsible to repair at no cost to the Owner any damage to property caused by Contractor's trimming work. Beds shall be edged as necessary to maintain a definition of outline per the original design intent.

- F. **FUNGICIDE, PESTICIDES AND HERBICIDES:** Any needed fungicide, pesticide or herbicide application due to disease or pest problems shall be monitored and reported to the Owner. Required application will be performed by the Contractor in accordance with the manufacturer's directions and all applicable local, State and Federal regulations. The Owner will reimburse the Contractor's actual out-of-pocket material costs with appropriate backup original invoices from the supplier; Contractor must obtain Owner's written approval prior to incurring any material costs for any repairs. After applying an herbicide, the irrigation system is to be turned off for a period of forty-eight (48) hours unless the label recommends "watering in." After the requested "dry period" the irrigation system is to be turned back on.

Pre-emergent weed control is required in all bed areas. Post emergent weed control shall be applied as needed to control weed growth in landscape beds, any pavement cracks, and turf. Pre-emergent weed control shall be applied two to three times per growing season. All personnel involved in the chemical program are to receive proper training and follow the operating guidelines provided by the DOT for chemical control. Contact the local County Agricultural Extension Service for additional information regarding herbicides, pesticides and required licenses.

Remove mechanically or by herbicide treatment all invasive exotic species (including aquatics) on an as needed basis. This includes all noxious weeds, FLEPPC (Florida Exotic Pest Plant Council) Category 1 and Category 2 listed plants, as well as Typha sp. (cattails).

- G. **PRUNING AND TRIMMING:** All areas shall be annually pruned or trimmed as needed to maintain an attractive appearance, maintain visibility and eliminate any safety problem. Clear trunk to be achieved and maintained is 8 feet for canopy shade trees, and single trunk accent trees. Multi-trunk trees shall have 5 feet clear trunk. Trees within the clear sight zones of intersections shall be maintained with a clear trunk of 8 ½ feet. Shrubs/ground cover within the clear site zones at intersections shall be maintained at a height no greater than 24 inches. In addition, Contractor shall remove all palm tree flower stalks and any broken palm fronds as required. Prune all plants as necessary to maintain proper form, health and vigor.
- H. **WEEDING AND MULCHING:** Weeds will be removed from flower and planting beds by hand once per month including grass and weeds from cracks in sidewalks and parking lots. An herbicide spray such as "Round Up" may be used on paved areas.

In addition, pine straw mulch shall be replaced as needed to maintain proper thickness in all bedding areas in the Spring and Fall. Mulching is to be performed around agreed upon dates with the City's point of contact. The designated times to apply mulch may be adjusted according to the conditions of the existing mulch. Mulching is to be performed two times annually and spread to one and one half (1 ½") inches thick. Only the areas where the mulch is very thin are to be mulched. Mulching is to be completed in seven (7) working days after commencing.

PCB24-12 ITB LANDSCAPING MAINTENANCE SERVICES
CITY MAIN CAMPUS FY2024

At all trees outside of a plant bed (if applicable), a 6-foot diameter ring of pine straw mulch shall be maintained; at all shrubs outside of a planting bed (if applicable), a 4-foot diameter ring of pine straw mulch shall be maintained; and in all planting beds, pine straw mulch shall be maintained continually.

- I. IRRIGATION: Existing irrigation shall be closely monitored to ensure efficient complete and appropriate watering of all landscape grass, plants and trees. Watering shall be applied during early morning. The Contractor shall be responsible for performing minor adjustments and services such as: flow control, radius adjustment, nozzle cleaning, sprinkler height, and level adjustment as a part of this contract. The Contractor shall monitor equipment for breakage, foreign materials, wear, proper coverage and electrical failure. Maintain the irrigation system (if applicable).

The Owner will reimburse the Contractor's actual, out-of-pocket irrigation repair material costs, documented with appropriate back-up original invoices from the supplier; Contractor must obtain Owner's written approval prior to incurring any material costs for any repairs. Any plant, tree, palm, or turf that dies from inadequate or excessive irrigation is to be replaced at the Contractor's expense.

The Contractor shall be responsible for performing a complete irrigation evaluation at commencement of the Contract and monthly thereafter. The Contractor shall be required to furnish the City of Panama City Beach's point of contact with a summary report of each clock and zone operation after each inspection. Contractor shall furnish recommendation for repair and improvements to the systems with an itemized cost for proposed work. Irrigation clocks shall have each zone identified within thirty (30) days of commencement of contract.

The Contractor is responsible for adjusting the irrigation as needed and turning off the irrigation before any freezes and turning it back on when the weather is appropriate.

- J. FERTILIZATION: All shrubs, trees and palms located at all areas shall be fertilized twice a year with an Owner approved 10-10-10 fertilizer or better with three different types of nitrogen. The proper rate of application shall be determined by the size of the shrubs, trees and palms.

In addition, all turf areas shall be fertilized twice a year with an Owner approved 10-10-10 or better fertilizer with three different types of nitrogen at the rate of ten (10) pounds per thousand square feet. All fertilizers shall be kept out of ditches and storm water retention ponds and immediately removed from sidewalks and roadways. Fertilizing shall be completed within five (5) working days after commencement.

In the event that additional fertilizer applications are required the Owner will reimburse the Contractor's actual, out-of-pocket material costs for the fertilizer, documented with appropriate back-up original invoices from the supplier; Contractor will be compensated at the hourly rate agreed upon in the 00030 Bid Proposal Form. Contractor must obtain Owner's written approval prior to incurring any material costs.

- K. pH ADJUSTMENT: If needed Contractor is responsible for adjusting improper pH by applying up to 50 pounds per 100 square feet of lime or up to 10 pounds of sulfur per 1000 square feet.

PCB24-12 ITB LANDSCAPING MAINTENANCE SERVICES
CITY MAIN CAMPUS FY2024

- L. STAKING: Staked trees and trees that need additional training shall be re-staked and adjusted as often as necessary. Stakes shall be adjusted and/or removed when deemed appropriate by Contractor. However, trees that need to be re-staked utilizing specialized equipment and crews shall be done at a mutually agreed upon price, submitted in writing for review and approval.
- M. DISPOSAL: Excessive grass cuttings, edging material, tree and shrub trimmings, weeds, leaves, and other debris shall be blown, raked and removed from grassed areas, sidewalks, streets, parking areas, shrub and planting beds.

All debris shall be legally disposed of off-site, in accordance with all applicable laws, rules and regulations, and shall not be allowed to remain overnight.

- N. DAMAGE: Grassed areas, trees or shrubs killed or damaged as a result of Contractor's actions (or the actions of anyone for whom Contractor is responsible) shall be repaired to original condition or replaced by the Contractor at no cost to the Owner.

In the event of any damage or deterioration of a site by natural or other causes, Contractor shall promptly notify the Owner, in its sole discretion, may accept, a proposal to repair or remedy any such problem, including repair to the irrigation system and its timers, and replacement of any foliage, trees, shrubbery, bedding plants, etc. (This includes auto accidents and fire accidents)

- O. SAFETY: The Contractor and all personnel shall abide by all safety regulations while performing any work on the landscaped sites.

All personnel shall wear safety vests; safety flags and signs shall be placed at proper locations along the right-of-way, and flashing yellow lights shall be on vehicles and other moving motorized equipment.

All safety equipment is to be furnished by the Contractor. All safety equipment shall be of the type approved by the Florida Department of Transportation. Failure to comply with all safety regulations could result in work being stopped until compliance is in effect.

PRICING: BID PROPOSAL FORM

The Contractor is required to bid:

- A. A total lump sum bid for all sites.
B. An Additional Work Unit Cost for the maintenance of additional work, subject to Contractor's availability;

Pricing Documentation: To verify that pricing remains compliant with the contract terms, the successful bidder shall be prepared to provide backup data such as labor timesheets, purchase receipts for part, etc. on demand. All invoices shall include a brief written job summary describing the repair, parts used, fees incurred, etc. so that City personnel may review/analyze the work completed for future planning, budgeting, and scheduling purposes.

PCB24-12 ITB LANDSCAPING MAINTENANCE SERVICES
CITY MAIN CAMPUS FY2024

DEFECTIVE WORK

All work completed by the Contractor at any time during the progress of the work shall be subject to the inspection by the City, who shall have full power to accept or reject any part thereof.

The contractor shall remedy any defective or unsatisfactory work at no additional cost to the City. In the event the Contractor fails to initiate corrections within 48-hours after written notice, the City shall have full right to have same done and to bill Contractor for cost thereof.

TERMS OF CONTRACT

- A. Payment will be made 30 days after satisfactory delivery and inspection of the services provided. The City shall determine the quality and acceptability of the services prior to payment. The City shall decide finally and conclusively any differences that may arise as to the interpretation of the specifications or the fulfillment of the terms of the Contract.
- B. Once accepted, all proposed pricing shall be firm and be valid for a period of twelve (12) months.
- C. Agreement is for two (2) years with two (2) one-year options at the mutual agreement of both parties.

OTHER CONSIDERATIONS FOR SCOPE OF WORK:

- a. The successful bidder shall supervise and direct the work, using skillful labor and proper equipment for all tasks. Safety of the bidder's personnel and equipment shall be the responsibility of the bidder.
- b. OSHA – Precautions shall be exercised at all times for the protection of persons and property. Bidder shall conform to all OSHA, State and County regulations while performing under the terms and conditions of this contract. Any fines levied by the above-mentioned authorities because of inadequacies to comply with these requirements shall be borne solely by the bidder responsible for the same.
- c. Licenses – The bidder must be duly licensed in accordance with the State's statutory requirements to perform the work identified herein. Proof of licensure shall be submitted with the bids. Required licenses shall be maintained and valid throughout the term of the contract.
- d. Permits – Bidder is responsible for obtaining any necessary State contractor's licenses and local business tax receipts (BTR).
- e. Damage to Property – The bidder shall use every method at their disposal to protect all properties they are working on/around. If the City project manager finds unnecessary damage to properties (public or private), the City shall invoke its authority to immediately terminate the contract and pay the bidder for work completed to date. The termination shall be effective **immediately** upon written notice by the City to the bidder.

The bidder will take care, and assume responsibility for any damage caused:

- a. The bidder shall assume full responsibility for any damage to any work areas or to the City, or of any adjacent lands or areas, resulting from the performance of the work on City property/easements. The bidder shall be responsible for repairing or replacing property to the satisfaction of the City which is damaged by the bidder.

PCB24-12 ITB LANDSCAPING MAINTENANCE SERVICES
CITY MAIN CAMPUS FY2024

- b. Should any claim be made by any such owner or occupant because of accident, intentional act, the performance of the work, or for any other such reason the cause of which is the bidder or its subcontractors, agents or employees, the bidder shall promptly settle such dispute by negotiation or otherwise resolve the claim by arbitration or other dispute resolutions proceeding or at law.
- f. Storage of Bidder's Equipment – The bidder shall be responsible for locating areas in which to store their equipment. Such areas shall not be located within the City parking lot if services are being performed during business hours.
- g. Violations – The bidder shall be responsible for taking corrective action in response to any notices of violations issued as a result of the bidder's or any Subcontractor's actions or operations during the performance of this contract. Corrections of any such violations shall be at no additional cost to the City.
- h. Additional Work – The City shall retain the option to add or remove work areas if it deems necessary.

[END OF SCOPE OF WORK/SPECIFICATIONS]

PCB24-12 ITB LANDSCAPING MAINTENANCE SERVICES
CITY MAIN CAMPUS FY2024

BID PROPOSAL FORM

TO: City of Panama City Beach, Florida

SUBMITTED: _____, 20____.

PCB24-12 ITB LANDSCAPING MAINTENANCE SERVICES CITY MAIN CAMPUS FY2024

The Undersigned, as Bidder, hereby declares that they have examined the bid specification and informed themselves fully regarding all terms and conditions pertaining to the product specifications.

The Bidder proposes and agrees, if this proposal is accepted, to contract with the **City of Panama City Beach** to perform the Work as specified in **PCB24-12 ITB LANDSCAPING MAINTENANCE SERVICES CITY MAIN CAMPUS FY2024** in accordance with the terms and conditions and bid specifications.

<u>ITEM NO:</u>	<u>DESCRIPTION:</u>	<u>COST:</u>
1.	City Hall Annex	
	A. Grass Cutting	\$ _____/per year
	B. Edging & Trimming	\$ _____/per year
	C. Pruning & Trimming	\$ _____/per year
	D. Fertilize & Pest Control	\$ _____/per year
	E. Herbicide & Fungicide	\$ _____/per year
	TOTAL	\$ _____/per year
2.	Public Services Admin. Building	
	A. Grass Cutting	\$ _____/per year
	B. Edging & Trimming	\$ _____/per year
	C. Pruning & Trimming	\$ _____/per year
	D. Fertilize & Pest Control	\$ _____/per year
	E. Herbicide & Fungicide	\$ _____/per year
	TOTAL	\$ _____/per year
3.	Plaza	
	A. Grass Cutting	\$ _____/per year
	B. Edging & Trimming	\$ _____/per year
	C. Pruning & Trimming	\$ _____/per year

PCB24-12 ITB LANDSCAPING MAINTENANCE SERVICES
CITY MAIN CAMPUS FY2024

D. Fertilize & Pest Control \$ _____/per year
E. Herbicide & Fungicide \$ _____/per year

TOTAL \$ _____/per year

4. **Panama City Beach Police Department**

A. Grass Cutting \$ _____/per year
B. Edging & Trimming \$ _____/per year
C. Pruning & Trimming \$ _____/per year
D. Fertilize & Pest Control \$ _____/per year
E. Herbicide & Fungicide \$ _____/per year

TOTAL \$ _____/per year

5. **Panama City Beach Fire Department #31**
(Located at 17121 PCB Parkway: City Main Campus)

A. Grass Cutting \$ _____/per year
B. Edging & Trimming \$ _____/per year
C. Pruning & Trimming \$ _____/per year
D. Fertilize & Pest Control \$ _____/per year
E. Herbicide & Fungicide \$ _____/per year

TOTAL \$ _____/per year

6. **Fuel Barn**

A. Grass Cutting \$ _____/per year
B. Edging & Trimming \$ _____/per year
C. Pruning & Trimming \$ _____/per year
D. Fertilize & Pest Control \$ _____/per year
E. Herbicide & Fungicide \$ _____/per year

TOTAL \$ _____/per year

7. **Police and Fire Storage**
(Located at 111 San Vicente St: City Main Campus)

A. Grass Cutting \$ _____/per year
B. Edging & Trimming \$ _____/per year
C. Pruning & Trimming \$ _____/per year
D. Pest Control \$ _____/per year

PCB24-12 ITB LANDSCAPING MAINTENANCE SERVICES
CITY MAIN CAMPUS FY2024

E. Herbicide & Fungicide \$ _____/per year

TOTAL \$ _____/per year

8. **Police Department Impound Lot**

A. Grass Cutting \$ _____/per year

B. Edging & Trimming \$ _____/per year

C. Pruning & Trimming \$ _____/per year

D. Pest Control \$ _____/per year

E. Herbicide & Fungicide \$ _____/per year

TOTAL \$ _____/per year

9. **Stormwater Pond #1**

A. Grass Cutting \$ _____/per year

B. Edging & Trimming \$ _____/per year

C. Pruning & Trimming \$ _____/per year

D. Fertilize & Pest Control \$ _____/per year

E. Herbicide & Fungicide \$ _____/per year

TOTAL \$ _____/per year

10. **Panama City Beach Fire Department #32**

(Located at 11911 Hutchison Blvd)

A. Grass Cutting \$ _____/per year

B. Edging & Trimming \$ _____/per year

C. Pruning & Trimming \$ _____/per year

D. Fertilize & Pest Control \$ _____/per year

E. Herbicide & Fungicide \$ _____/per year

TOTAL \$ _____/per year

Total of All Combined (1 - 10) \$ _____/per year

ADDITIONAL WORK – UNIT COST

Description	Unit Cost
Fungicide, Pesticide & Herbicide Labor	_____ Per Hour
Fertilizer Labor	_____ Per Hour
Irrigation Repair Labor	_____ Per Hour
Bedding Plants Labor	_____ Per Hour
Emergency Irrigation Repairs Labor	_____ Per Hour
Rye over seeding	_____ Per 1000 Square ft.
Extra Litter Control Cycle	_____ Per Visit

NOTE:

The City reserves the right to reject any and all bids received and may award the contract based upon either lowest bid or a bid and delivery time which the City deems to be in its best interest.

By submission of this BID, Bidder certifies that this BID has been arrived at independently, without consultation, communication, or agreement as to any matter relating to this BID with any other BIDDER or with any other competitor.

In submitting this Bid, Bidder represents as more fully set forth in the agreement, that Bidder has examined copies of all the contract Documents and of the following Addenda:

Addendum No: _____ Dated: _____ Addendum No: _____ Dated: _____

Addendum No: _____ Dated: _____ Addendum No: _____ Dated: _____

The undersigned declares that, after examining the Bid Documents for the above referenced service, she/he does hereby submit a response to the bid and warrants that:

1. She/He is an officer of the organization.
2. She/He is authorized to offer a bid in full compliance with all requirements and conditions, as set forth in the solicitation.
3. All bids shall remain firm and valid for a period of sixty (60 days) from the date of opening.

BIDDER:

Name of Business

Name of Bidder

PCB24-12 ITB LANDSCAPING MAINTENANCE SERVICES
CITY MAIN CAMPUS FY2024

Address

Phone Number

Email Address

Signature of Authorized Representative

Title of Authorized Representative

Date

[END OF BID PROPOSAL FORM]

PCB24-12 ITB LANDSCAPING MAINTENANCE SERVICES
CITY MAIN CAMPUS FY2024

REFERENCES FORM

Bidder shall provide a minimum of five references, for which they are currently providing this type of service/commodity within the State of Florida.

BIDDER shall submit at least three out of five of the references that are contracts of similar size and scope to the Statement of Work.

1. Client: _____ Contact: _____

Contact Phone: _____ Email: _____

Job Start Date: _____ Job Completion Date: _____

2. Client: _____ Contact: _____

Contact Phone: _____ Email: _____

Job Start Date: _____ Job Completion Date: _____

3. Client: _____ Contact: _____

Contact Phone: _____ Email: _____

Job Start Date: _____ Job Completion Date: _____

4. Client: _____ Contact: _____

Contact Phone: _____ Email: _____

Job Start Date: _____ Job Completion Date: _____

5. Client: _____ Contact: _____

Contact Phone: _____ Email: _____

Job Start Date: _____ Job Completion Date: _____

PCB24-12 ITB LANDSCAPING MAINTENANCE SERVICES
CITY MAIN CAMPUS FY2024



CITY OF PANAMA CITY BEACH

**PCB24-12 ITB LANDSCAPING MAINTENANCE SERVICES
CITY MAIN CAMPUS FY2024**

REQUIRED DOCUMENTS

CONFLICT OF INTEREST STATEMENT

Check one:

To the best of our knowledge, the undersigned Respondent has no potential conflict of interest due to any other clients, contracts, or property interest for this project.

or

The undersigned Respondent, by attachment to this form, submits information which may be a potential conflict of interest due to other clients, contracts, or property interest for this project. This includes and requires disclosure of any officer, director, partner, proprietor, associate, or agent of the Respondent who is also an officer or employee of the City or of its boards or committees.

LITIGATION STATEMENT

Check one:

The undersigned Respondent has had no litigation and/or judgements entered against it by any local, state, or federal entity and has had no litigation and/or judgements entered against such entities during the past ten (10) years.

or

The undersigned Respondent, by attachment to this form, submits a summary and disposition of individual cases of litigation and/or judgements entered by or against any local, state, or federal entity, by any state or federal court, during the past ten (10) years.

COMPANY: _____

SIGNATURE: _____

NAME: _____

TITLE: _____

DATE: _____

Failure to check the appropriate blocks above may result in disqualification of your proposal. Likewise, failure to provide documentation of a possible conflict of interest, or a summary of past litigation and/or judgements, may result in disqualification of your proposal.

DRUG FREE WORKPLACE

STATEMENT UNDER SECTION 287.287 FLORIDA STATUTES,
ON PREFERENCE TO BUSINESSES WITH DRUG-FREE
WORKPLACE PROGRAMS

IDENTICAL TIE BIDS: Preference shall be given to businesses with drug-free workplace programs. Whenever two or more BIDS which are equal with respect to price, quality and service are received by the OWNER for this PRODUCT and SERVICE, a bid received from a BIDDER that certifies that it has implemented a drug-free workplace program shall be given preference in the award process. In order to have a drug-free workplace program, a business shall:

1. Publish a statement notifying employees that the unlawful manufacture, distribution, dispensing, possession, or use of a controlled substance is prohibited in the workplace and specifying the actions that will be taken against employees for violations of such prohibition.
2. Inform employees about the dangers of drug abuse in the workplace, business' policy of maintaining a drug-free workplace, any available drug counseling, rehabilitation, and employee assistance programs, and the penalties that may be imposed upon employees for drug abuse violations.
3. Give each employee engaged in providing the commodities or contractual services that are under BID a copy of the statement specified in paragraph (1).
4. In the statement specified in paragraph (1), notify that employees that, as a condition of working on the commodities or contractual services that are under BID, the employee will abide by the terms of the statement and will notify the employer of any conviction of, or plea of guilty or nolo contendere to, any violation of Chapter 893 or of any controlled substance law of the United States or of any state, for a violation occurring in the workplace not later than five (5) days after such conviction.
5. Impose a sanction on or require the satisfactory participation in a drug abuse assistance or rehabilitation program if such is available in the employee's community, by an employee who is so convicted.
6. Make a good faith effort to continue to maintain a drug-free workplace through implementation of this Section.

As the person authorized to sign this statement, I certify that this form complies fully with the above requirements.

NAME OF COMPANY/FIRM

AUTHORIZED SIGNATURE

CONTRACTOR/VENDOR E-VERIFY FORM

PER FLORIDA STATUTE 448.95, CONTRACTORS/VENDORS AND SUB-CONTRACTORS MUST REGISTER WITH AND USE THE E-VERIFY SYSTEM TO VERIFY THE WORK AUTHORIZATION STATUS OF ALL NEWLY HIRED EMPLOYEES.

THIS FORM MUST BE COMPLETED AND SUBMITTED WITH THE BID/PROPOSAL. FAILURE TO SUBMIT THIS FORM AS REQUIRED MAY DEEM YOUR SUBMITTAL NONRESPONSIVE.

The affiant, by virtue of the signature below, certifies that:

1. The Contractor/Vendor and its Subcontractors are aware of the requirements of Florida Statute 448.095.
2. The Contractor/Vendor and its Subcontractors are registered with and using the E-Verify system to verify the work authorization status of newly hired employees.
3. The Contractor/Vendor will not enter into a contract with any Subcontractor unless each party to the contract registers with and uses the E-Verify system.
4. The Subcontractor will provide the Contractor/Vendor with an affidavit stating that the Subcontractor does not employ, contract with, or subcontract with unauthorized aliens.
5. All employees hired by Contractor/Vendor on or after January 1, 2021, have had their work authorization status verified through the E-Verify system.
6. The City may terminate this contract on the good faith belief that the Contract or its Subcontractors knowingly violated Florida Statutes 448.09(1) or 448.095(2)(c).
7. If this Contract is terminated pursuant to Florida Statute 448.095(2)(c), the Contractor/Vendor may not be awarded a public contract for at least one year after the date on which this Contract was terminated.
8. The Contractor/Vendor is liable for any additional cost incurred by the City as a result of the termination of this Contract.

Authorized Signature

Printed Name

Title

Name of Entity/Corporation

STATE OF _____
COUNTY OF _____

The forgoing instrument was acknowledged before me by means of _____ physical presence or _____ online notarization on, this _____ day of _____, 20 ____, by

_____ (name of person whose signature is being notarized) as the _____ (title) of _____ (name of entity/corporation), personally know, or produced _____ (type of identification) as identification, and who did/did not take an oath.

Notary Public

My Commission Expires: _____
NOTARY SEAL ABOVE

Printed Name

NON-COLLUSION AFFIDAVIT

STATE OF _____

COUNTY OF _____

_____ Bing, first duly sworn, deposes and says that
he/she is _____ of _____

_____, the party making the forgoing Proposal or Bid; that such Bid is genuine and not collusive or sham; that said bidder is not financially interested in or otherwise affiliated in a business way with any other bidder on the same contract; that said bidder has not colluded, conspired, connived, or agreed, directly or indirectly, with any bidders or person, to put in a sham bid or that such other person shall refrain from bidding, and has not in any manner, directly or indirectly, sought by agreement or collusion, or communication or conference, with any person, to fix the bid price or affiant or any other bidder, or to fix any overhead, profit or cost element of said bid price, or that of any other bidder, or to secure any advantage against the City of Panama City Beach, Florida, or any person or persons interested in the proposed contract, and that all statements contained in said proposal or bid are true; and further, that such bidder has not directly or indirectly submitted this bid, or the contents thereof, or divulged information or data relative thereto any association or to any member or agent thereof.

Affiant

Sworn to and subscribed before me this ____ day of _____, 20 ____.

Notary Public

PUBLIC ENTITY CRIMES FORM

SWORN STATEMENT UNDER SECTION 287.133(3)(A), FLORIDA STATUTES,
ON PUBLIC ENTITY CRIMES

THIS FORM MUST BE SIGNED AND SWORN TO IN THE PRESENCE OF A NOTARY PUBLIC OR OTHER OFFICIAL AUTHORIZED TO ADMINISTER OATHS AND SUBMITTED WITH THE BID.

1. This sworn statement is submitted to the City of Panama City Beach

by _____

for Bid No.: _____

whose business address is:

and (if applicable) its Federal Employer Identification Number (FEIN) is

(if the entity has no FEIN, include the Social Security Number of the individual signing this sworn statement): _____

2. I understand that a “public entity crime” as defined in Section 287.133 (1)(g), Florida Statutes, means a violation of any state or federal law by a person with respect to and directly related to the transaction of business with any public entity or with an agency or political subdivision of any other state or with the United States, including, but not limited to, any bid, proposal, reply, or contract for goods or services, or any lease for real property, or any contract for the construction or repair of a public building or public work, involving antitrust, fraud, theft, bribery, collusion, racketeering, conspiracy, or material misrepresentation.

I understand that “convicted” or “conviction” as defined in Section 287.133 (1)(b), Florida Statutes, means a finding of guilt or a conviction of a public entity crime, with or without an adjudication of guilt, in any federal or state trial court of record relating to charges brought by indictment or information after July 1, 1989, as a result of a jury verdict, nonjury trial, or entry of a plea of guilty or nolo contendere.

3. I understand that “affiliate” as defined in Section 287.133(1)(a), Florida Statutes, means:
(a) A predecessor or successor of a person convicted of a public entity crime, or
(b) An entity under the control of any natural person who is active in the management of the entity and who has been convicted of a public entity crime. The term “affiliate” includes those officers, directors, executives, partners, shareholders, employees, members, and

agents who are active in the management of an affiliate. The ownership by one person of shares constituting a controlling interest in another person, or a pooling of equipment or income among persons when not for fair market value under an arm's length agreement, shall be a prima facie case that one person controls another person. A person who knowingly enters into a joint venture with a person who has been convicted of a public entity crime in Florida during the preceding 36 months shall be considered an affiliate.

4. I understand that a "person" as defined in Section 287-133(1)(e), Florida Statute, means any natural person or any entity organized under the laws of any state or of the United States with the legal power to enter into a binding contract and which bids or applies to bid on contract led by a public entity, or which otherwise transacts or applies to transact business with a public entity. The term "person" includes those officers, directors, executives, partners, shareholders, employees, members, and agents who are in active management of an entity.
5. Based on information and belief, the statement which I have marked below is true in relation to the person submitting this sworn statement. [Indicate which statement applies.]

_____ Neither the person submitting this sworn statement, nor any affiliate of the person has been charged with and convicted of a public entity crime causing such person or affiliate to be placed on the convicted vendor list within the last thirty-six (36) months.

_____ The person submitting this sworn statement, or an affiliate of the person has been charged with and convicted of a public entity crime causing such person or affiliate to be placed on the convicted vendor list within the last thirty-six (36) months.

_____ The person submitting this sworn statement, or an affiliate of the person has been charged with and convicted of a public entity crime causing such person or affiliate to be placed on the convicted vendor list within the last thirty-six (36) months. However, it has been determined, pursuant to Section 287-133, Florida Statutes, that it was not in the public interest to place the person submitting this sworn statement or its affiliate on the convicted vendor list. [Attach a copy of the final order.]

6. I understand by my execution of this document, I acknowledge that the person submitting this sworn statement has been informed by the City of Panama City Beach, of the terms of Section 287-133(2)(a) of the Florida Statutes which read as follows:

"A person or affiliate who has been placed on the convicted vendor list following a conviction for a public entity crime may not submit a bid, proposal, or rely on a contract to provide any goods or services to a public entity; may not submit a bid, proposal, or reply on a contract with a public entity for the construction or repair of a public building or public work; may not submit bids, proposals, or replies on leases of real property to a public entity; may not be awarded or perform work as a Bidder, supplier, sub-Bidder, or consultant under a contract with any public entity; and may not transact business with any public entity in excess of the threshold amount provided in Section 287-017 for CATEGORY TWO for a period of 36 months following the date of being placed on the convicted vendor list."

7. I UNDERSTAND THAT THE SUBMISSION OF THIS FORM TO THE CONTRACTING OFFICER FOR THE PUBLIC ENTITY IDENTIFIED IN PARAGRAPH 1 (ONE) ABOVE IS FOR THE PUBLIC ENTITY ONLY AND THAT THIS FORM IS VALID THROUGH DECEMBER 31 OF THE CALENDAR YEAR IN WHICH IT IS FILED. I ALSO UNDERSTAND THAT I AM REQUIRED TO INFORM THE PUBLIC ENTITY IMMEDIATELY OF ANY CHANGE IN THE INFORMATION CONTAINED IN THIS FORM.

By: _____

Print Name: _____

Its: _____

Sworn to and subscribed before me this ____ day of _____, 20__ .

Personally know _____ OR Produced Identification _____

Notary Public – State of _____

My commission expires: _____

[printed, typed, or stamped Commissioned Name
Of Notary Public]

[END OF PUBLIC ENTITY CRIMES]

By signing the filled-out form, you:

1. Certify that the TIN you are giving is correct (or you are waiting for a number to be issued),
2. Certify that you are not subject to backup withholding, or
3. Claim exemption from backup withholding if you are a U.S. exempt payee. If applicable, you are also certifying that as a U.S. person, your allocable share of any partnership income from a U.S. trade or business is not subject to the withholding tax on foreign partners' share of effectively connected income, and
4. Certify that FATCA code(s) entered on this form (if any) indicating that you are exempt from the FATCA reporting, is correct. See *What is FATCA reporting*, later, for further information.

Note: If you are a U.S. person and a requester gives you a form other than Form W-9 to request your TIN, you must use the requester's form if it is substantially similar to this Form W-9.

Definition of a U.S. person. For federal tax purposes, you are considered a U.S. person if you are:

- An individual who is a U.S. citizen or U.S. resident alien;
- A partnership, corporation, company, or association created or organized in the United States or under the laws of the United States;
- An estate (other than a foreign estate); or
- A domestic trust (as defined in Regulations section 301.7701-7).

Special rules for partnerships. Partnerships that conduct a trade or business in the United States are generally required to pay a withholding tax under section 1446 on any foreign partners' share of effectively connected taxable income from such business. Further, in certain cases where a Form W-9 has not been received, the rules under section 1446 require a partnership to presume that a partner is a foreign person, and pay the section 1446 withholding tax. Therefore, if you are a U.S. person that is a partner in a partnership conducting a trade or business in the United States, provide Form W-9 to the partnership to establish your U.S. status and avoid section 1446 withholding on your share of partnership income.

In the cases below, the following person must give Form W-9 to the partnership for purposes of establishing its U.S. status and avoiding withholding on its allocable share of net income from the partnership conducting a trade or business in the United States.

- In the case of a disregarded entity with a U.S. owner, the U.S. owner of the disregarded entity and not the entity;
- In the case of a grantor trust with a U.S. grantor or other U.S. owner, generally, the U.S. grantor or other U.S. owner of the grantor trust and not the trust; and
- In the case of a U.S. trust (other than a grantor trust), the U.S. trust (other than a grantor trust) and not the beneficiaries of the trust.

Foreign person. If you are a foreign person or the U.S. branch of a foreign bank that has elected to be treated as a U.S. person, do not use Form W-9. Instead, use the appropriate Form W-8 or Form 8233 (see Pub. 515, *Withholding of Tax on Nonresident Aliens and Foreign Entities*).

Nonresident alien who becomes a resident alien. Generally, only a nonresident alien individual may use the terms of a tax treaty to reduce or eliminate U.S. tax on certain types of income. However, most tax treaties contain a provision known as a "saving clause." Exceptions specified in the saving clause may permit an exemption from tax to continue for certain types of income even after the payee has otherwise become a U.S. resident alien for tax purposes.

If you are a U.S. resident alien who is relying on an exception contained in the saving clause of a tax treaty to claim an exemption from U.S. tax on certain types of income, you must attach a statement to Form W-9 that specifies the following five items.

1. The treaty country. Generally, this must be the same treaty under which you claimed exemption from tax as a nonresident alien.
2. The treaty article addressing the income.
3. The article number (or location) in the tax treaty that contains the saving clause and its exceptions.
4. The type and amount of income that qualifies for the exemption from tax.
5. Sufficient facts to justify the exemption from tax under the terms of the treaty article.

Example. Article 20 of the U.S.-China income tax treaty allows an exemption from tax for scholarship income received by a Chinese student temporarily present in the United States. Under U.S. law, this student will become a resident alien for tax purposes if his or her stay in the United States exceeds 5 calendar years. However, paragraph 2 of the first Protocol to the U.S.-China treaty (dated April 30, 1984) allows the provisions of Article 20 to continue to apply even after the Chinese student becomes a resident alien of the United States. A Chinese student who qualifies for this exception (under paragraph 2 of the first protocol) and is relying on this exception to claim an exemption from tax on his or her scholarship or fellowship income would attach to Form W-9 a statement that includes the information described above to support that exemption.

If you are a nonresident alien or a foreign entity, give the requester the appropriate completed Form W-8 or Form 8233.

Backup Withholding

What is backup withholding? Persons making certain payments to you must under certain conditions withhold and pay to the IRS 24% of such payments. This is called "backup withholding." Payments that may be subject to backup withholding include interest, tax-exempt interest, dividends, broker and barter exchange transactions, rents, royalties, nonemployee pay, payments made in settlement of payment card and third party network transactions, and certain payments from fishing boat operators. Real estate transactions are not subject to backup withholding.

You will not be subject to backup withholding on payments you receive if you give the requester your correct TIN, make the proper certifications, and report all your taxable interest and dividends on your tax return.

Payments you receive will be subject to backup withholding if:

1. You do not furnish your TIN to the requester,
2. You do not certify your TIN when required (see the instructions for Part II for details),
3. The IRS tells the requester that you furnished an incorrect TIN,
4. The IRS tells you that you are subject to backup withholding because you did not report all your interest and dividends on your tax return (for reportable interest and dividends only), or
5. You do not certify to the requester that you are not subject to backup withholding under 4 above (for reportable interest and dividend accounts opened after 1983 only).

Certain payees and payments are exempt from backup withholding. See *Exempt payee code*, later, and the separate Instructions for the Requester of Form W-9 for more information.

Also see *Special rules for partnerships*, earlier.

What is FATCA Reporting?

The Foreign Account Tax Compliance Act (FATCA) requires a participating foreign financial institution to report all United States account holders that are specified United States persons. Certain payees are exempt from FATCA reporting. See *Exemption from FATCA reporting code*, later, and the Instructions for the Requester of Form W-9 for more information.

Updating Your Information

You must provide updated information to any person to whom you claimed to be an exempt payee if you are no longer an exempt payee and anticipate receiving reportable payments in the future from this person. For example, you may need to provide updated information if you are a C corporation that elects to be an S corporation, or if you no longer are tax exempt. In addition, you must furnish a new Form W-9 if the name or TIN changes for the account; for example, if the grantor of a grantor trust dies.

Penalties

Failure to furnish TIN. If you fail to furnish your correct TIN to a requester, you are subject to a penalty of \$50 for each such failure unless your failure is due to reasonable cause and not to willful neglect.

Civil penalty for false information with respect to withholding. If you make a false statement with no reasonable basis that results in no backup withholding, you are subject to a \$500 penalty.

Criminal penalty for falsifying information. Willfully falsifying certifications or affirmations may subject you to criminal penalties including fines and/or imprisonment.

Misuse of TINs. If the requester discloses or uses TINs in violation of federal law, the requester may be subject to civil and criminal penalties.

Specific Instructions

Line 1

You must enter one of the following on this line; **do not** leave this line blank. The name should match the name on your tax return.

If this Form W-9 is for a joint account (other than an account maintained by a foreign financial institution (FFI)), list first, and then circle, the name of the person or entity whose number you entered in Part I of Form W-9. If you are providing Form W-9 to an FFI to document a joint account, each holder of the account that is a U.S. person must provide a Form W-9.

a. Individual. Generally, enter the name shown on your tax return. If you have changed your last name without informing the Social Security Administration (SSA) of the name change, enter your first name, the last name as shown on your social security card, and your new last name.

Note: ITIN applicant: Enter your individual name as it was entered on your Form W-7 application, line 1a. This should also be the same as the name you entered on the Form 1040/1040A/1040EZ you filed with your application.

b. Sole proprietor or single-member LLC. Enter your individual name as shown on your 1040/1040A/1040EZ on line 1. You may enter your business, trade, or “doing business as” (DBA) name on line 2.

c. Partnership, LLC that is not a single-member LLC, C corporation, or S corporation. Enter the entity’s name as shown on the entity’s tax return on line 1 and any business, trade, or DBA name on line 2.

d. Other entities. Enter your name as shown on required U.S. federal tax documents on line 1. This name should match the name shown on the charter or other legal document creating the entity. You may enter any business, trade, or DBA name on line 2.

e. Disregarded entity. For U.S. federal tax purposes, an entity that is disregarded as an entity separate from its owner is treated as a “disregarded entity.” See Regulations section 301.7701-2(c)(2)(iii). Enter the owner’s name on line 1. The name of the entity entered on line 1 should never be a disregarded entity. The name on line 1 should be the name shown on the income tax return on which the income should be reported. For example, if a foreign LLC that is treated as a disregarded entity for U.S. federal tax purposes has a single owner that is a U.S. person, the U.S. owner’s name is required to be provided on line 1. If the direct owner of the entity is also a disregarded entity, enter the first owner that is not disregarded for federal tax purposes. Enter the disregarded entity’s name on line 2, “Business name/disregarded entity name.” If the owner of the disregarded entity is a foreign person, the owner must complete an appropriate Form W-8 instead of a Form W-9. This is the case even if the foreign person has a U.S. TIN.

Line 2

If you have a business name, trade name, DBA name, or disregarded entity name, you may enter it on line 2.

Line 3

Check the appropriate box on line 3 for the U.S. federal tax classification of the person whose name is entered on line 1. Check only one box on line 3.

IF the entity/person on line 1 is a(n) . . .	THEN check the box for . . .
• Corporation	Corporation
• Individual • Sole proprietorship, or • Single-member limited liability company (LLC) owned by an individual and disregarded for U.S. federal tax purposes.	Individual/sole proprietor or single-member LLC
• LLC treated as a partnership for U.S. federal tax purposes, • LLC that has filed Form 8832 or 2553 to be taxed as a corporation, or • LLC that is disregarded as an entity separate from its owner but the owner is another LLC that is not disregarded for U.S. federal tax purposes.	Limited liability company and enter the appropriate tax classification. (P= Partnership; C= C corporation; or S= S corporation)
• Partnership	Partnership
• Trust/estate	Trust/estate

Line 4, Exemptions

If you are exempt from backup withholding and/or FATCA reporting, enter in the appropriate space on line 4 any code(s) that may apply to you.

Exempt payee code.

- Generally, individuals (including sole proprietors) are not exempt from backup withholding.
- Except as provided below, corporations are exempt from backup withholding for certain payments, including interest and dividends.
- Corporations are not exempt from backup withholding for payments made in settlement of payment card or third party network transactions.
- Corporations are not exempt from backup withholding with respect to attorneys’ fees or gross proceeds paid to attorneys, and corporations that provide medical or health care services are not exempt with respect to payments reportable on Form 1099-MISC.

The following codes identify payees that are exempt from backup withholding. Enter the appropriate code in the space in line 4.

- 1—An organization exempt from tax under section 501(a), any IRA, or a custodial account under section 403(b)(7) if the account satisfies the requirements of section 401(f)(2)
- 2—The United States or any of its agencies or instrumentalities
- 3—A state, the District of Columbia, a U.S. commonwealth or possession, or any of their political subdivisions or instrumentalities
- 4—A foreign government or any of its political subdivisions, agencies, or instrumentalities
- 5—A corporation
- 6—A dealer in securities or commodities required to register in the United States, the District of Columbia, or a U.S. commonwealth or possession
- 7—A futures commission merchant registered with the Commodity Futures Trading Commission
- 8—A real estate investment trust
- 9—An entity registered at all times during the tax year under the Investment Company Act of 1940
- 10—A common trust fund operated by a bank under section 584(a)
- 11—A financial institution
- 12—A middleman known in the investment community as a nominee or custodian
- 13—A trust exempt from tax under section 664 or described in section 4947

The following chart shows types of payments that may be exempt from backup withholding. The chart applies to the exempt payees listed above, 1 through 13.

IF the payment is for . . .	THEN the payment is exempt for . . .
Interest and dividend payments	All exempt payees except for 7
Broker transactions	Exempt payees 1 through 4 and 6 through 11 and all C corporations. S corporations must not enter an exempt payee code because they are exempt only for sales of noncovered securities acquired prior to 2012.
Barter exchange transactions and patronage dividends	Exempt payees 1 through 4
Payments over \$600 required to be reported and direct sales over \$5,000 ¹	Generally, exempt payees 1 through 5 ²
Payments made in settlement of payment card or third party network transactions	Exempt payees 1 through 4

¹ See Form 1099-MISC, Miscellaneous Income, and its instructions.

² However, the following payments made to a corporation and reportable on Form 1099-MISC are not exempt from backup withholding: medical and health care payments, attorneys' fees, gross proceeds paid to an attorney reportable under section 6045(f), and payments for services paid by a federal executive agency.

Exemption from FATCA reporting code. The following codes identify payees that are exempt from reporting under FATCA. These codes apply to persons submitting this form for accounts maintained outside of the United States by certain foreign financial institutions. Therefore, if you are only submitting this form for an account you hold in the United States, you may leave this field blank. Consult with the person requesting this form if you are uncertain if the financial institution is subject to these requirements. A requester may indicate that a code is not required by providing you with a Form W-9 with "Not Applicable" (or any similar indication) written or printed on the line for a FATCA exemption code.

A—An organization exempt from tax under section 501(a) or any individual retirement plan as defined in section 7701(a)(37)

B—The United States or any of its agencies or instrumentalities

C—A state, the District of Columbia, a U.S. commonwealth or possession, or any of their political subdivisions or instrumentalities

D—A corporation the stock of which is regularly traded on one or more established securities markets, as described in Regulations section 1.1472-1(c)(1)(i)

E—A corporation that is a member of the same expanded affiliated group as a corporation described in Regulations section 1.1472-1(c)(1)(i)

F—A dealer in securities, commodities, or derivative financial instruments (including notional principal contracts, futures, forwards, and options) that is registered as such under the laws of the United States or any state

G—A real estate investment trust

H—A regulated investment company as defined in section 851 or an entity registered at all times during the tax year under the Investment Company Act of 1940

I—A common trust fund as defined in section 584(a)

J—A bank as defined in section 581

K—A broker

L—A trust exempt from tax under section 664 or described in section 4947(a)(1)

M—A tax exempt trust under a section 403(b) plan or section 457(g) plan

Note: You may wish to consult with the financial institution requesting this form to determine whether the FATCA code and/or exempt payee code should be completed.

Line 5

Enter your address (number, street, and apartment or suite number). This is where the requester of this Form W-9 will mail your information returns. If this address differs from the one the requester already has on file, write NEW at the top. If a new address is provided, there is still a chance the old address will be used until the payor changes your address in their records.

Line 6

Enter your city, state, and ZIP code.

Part I. Taxpayer Identification Number (TIN)

Enter your TIN in the appropriate box. If you are a resident alien and you do not have and are not eligible to get an SSN, your TIN is your IRS individual taxpayer identification number (ITIN). Enter it in the social security number box. If you do not have an ITIN, see *How to get a TIN* below.

If you are a sole proprietor and you have an EIN, you may enter either your SSN or EIN.

If you are a single-member LLC that is disregarded as an entity separate from its owner, enter the owner's SSN (or EIN, if the owner has one). Do not enter the disregarded entity's EIN. If the LLC is classified as a corporation or partnership, enter the entity's EIN.

Note: See *What Name and Number To Give the Requester*, later, for further clarification of name and TIN combinations.

How to get a TIN. If you do not have a TIN, apply for one immediately. To apply for an SSN, get Form SS-5, Application for a Social Security Card, from your local SSA office or get this form online at www.SSA.gov. You may also get this form by calling 1-800-772-1213. Use Form W-7, Application for IRS Individual Taxpayer Identification Number, to apply for an ITIN, or Form SS-4, Application for Employer Identification Number, to apply for an EIN. You can apply for an EIN online by accessing the IRS website at www.irs.gov/Businesses and clicking on Employer Identification Number (EIN) under Starting a Business. Go to www.irs.gov/Forms to view, download, or print Form W-7 and/or Form SS-4. Or, you can go to www.irs.gov/OrderForms to place an order and have Form W-7 and/or SS-4 mailed to you within 10 business days.

If you are asked to complete Form W-9 but do not have a TIN, apply for a TIN and write "Applied For" in the space for the TIN, sign and date the form, and give it to the requester. For interest and dividend payments, and certain payments made with respect to readily tradable instruments, generally you will have 60 days to get a TIN and give it to the requester before you are subject to backup withholding on payments. The 60-day rule does not apply to other types of payments. You will be subject to backup withholding on all such payments until you provide your TIN to the requester.

Note: Entering "Applied For" means that you have already applied for a TIN or that you intend to apply for one soon.

Caution: A disregarded U.S. entity that has a foreign owner must use the appropriate Form W-8.

Part II. Certification

To establish to the withholding agent that you are a U.S. person, or resident alien, sign Form W-9. You may be requested to sign by the withholding agent even if item 1, 4, or 5 below indicates otherwise.

For a joint account, only the person whose TIN is shown in Part I should sign (when required). In the case of a disregarded entity, the person identified on line 1 must sign. Exempt payees, see *Exempt payee code*, earlier.

Signature requirements. Complete the certification as indicated in items 1 through 5 below.

1. Interest, dividend, and barter exchange accounts opened before 1984 and broker accounts considered active during 1983. You must give your correct TIN, but you do not have to sign the certification.

2. Interest, dividend, broker, and barter exchange accounts opened after 1983 and broker accounts considered inactive during 1983. You must sign the certification or backup withholding will apply. If you are subject to backup withholding and you are merely providing your correct TIN to the requester, you must cross out item 2 in the certification before signing the form.

3. Real estate transactions. You must sign the certification. You may cross out item 2 of the certification.

4. Other payments. You must give your correct TIN, but you do not have to sign the certification unless you have been notified that you have previously given an incorrect TIN. "Other payments" include payments made in the course of the requester's trade or business for rents, royalties, goods (other than bills for merchandise), medical and health care services (including payments to corporations), payments to a nonemployee for services, payments made in settlement of payment card and third party network transactions, payments to certain fishing boat crew members and fishermen, and gross proceeds paid to attorneys (including payments to corporations).

5. Mortgage interest paid by you, acquisition or abandonment of secured property, cancellation of debt, qualified tuition program payments (under section 529), ABLE accounts (under section 529A), IRA, Coverdell ESA, Archer MSA or HSA contributions or distributions, and pension distributions. You must give your correct TIN, but you do not have to sign the certification.

What Name and Number To Give the Requester

For this type of account:	Give name and SSN of:
1. Individual	The individual
2. Two or more individuals (joint account) other than an account maintained by an FFI	The actual owner of the account or, if combined funds, the first individual on the account ¹
3. Two or more U.S. persons (joint account maintained by an FFI)	Each holder of the account
4. Custodial account of a minor (Uniform Gift to Minors Act)	The minor ²
5. a. The usual revocable savings trust (grantor is also trustee)	The grantor-trustee ¹
b. So-called trust account that is not a legal or valid trust under state law	The actual owner ¹
6. Sole proprietorship or disregarded entity owned by an individual	The owner ³
7. Grantor trust filing under Optional Form 1099 Filing Method 1 (see Regulations section 1.671-4(b)(2)(i)(A))	The grantor*
For this type of account:	Give name and EIN of:
8. Disregarded entity not owned by an individual	The owner
9. A valid trust, estate, or pension trust	Legal entity ⁴
10. Corporation or LLC electing corporate status on Form 8832 or Form 2553	The corporation
11. Association, club, religious, charitable, educational, or other tax-exempt organization	The organization
12. Partnership or multi-member LLC	The partnership
13. A broker or registered nominee	The broker or nominee

For this type of account:	Give name and EIN of:
14. Account with the Department of Agriculture in the name of a public entity (such as a state or local government, school district, or prison) that receives agricultural program payments	The public entity
15. Grantor trust filing under the Form 1041 Filing Method or the Optional Form 1099 Filing Method 2 (see Regulations section 1.671-4(b)(2)(j)(E))	The trust

¹ List first and circle the name of the person whose number you furnish. If only one person on a joint account has an SSN, that person's number must be furnished.

² Circle the minor's name and furnish the minor's SSN.

³ You must show your individual name and you may also enter your business or DBA name on the "Business name/disregarded entity" name line. You may use either your SSN or EIN (if you have one), but the IRS encourages you to use your SSN.

⁴ List first and circle the name of the trust, estate, or pension trust. (Do not furnish the TIN of the personal representative or trustee unless the legal entity itself is not designated in the account title.) Also see *Special rules for partnerships*, earlier.

*Note: The grantor also must provide a Form W-9 to trustee of trust.

Note: If no name is circled when more than one name is listed, the number will be considered to be that of the first name listed.

Secure Your Tax Records From Identity Theft

Identity theft occurs when someone uses your personal information such as your name, SSN, or other identifying information, without your permission, to commit fraud or other crimes. An identity thief may use your SSN to get a job or may file a tax return using your SSN to receive a refund.

To reduce your risk:

- Protect your SSN,
- Ensure your employer is protecting your SSN, and
- Be careful when choosing a tax preparer.

If your tax records are affected by identity theft and you receive a notice from the IRS, respond right away to the name and phone number printed on the IRS notice or letter.

If your tax records are not currently affected by identity theft but you think you are at risk due to a lost or stolen purse or wallet, questionable credit card activity or credit report, contact the IRS Identity Theft Hotline at 1-800-908-4490 or submit Form 14039.

For more information, see Pub. 5027, Identity Theft Information for Taxpayers.

Victims of identity theft who are experiencing economic harm or a systemic problem, or are seeking help in resolving tax problems that have not been resolved through normal channels, may be eligible for Taxpayer Advocate Service (TAS) assistance. You can reach TAS by calling the TAS toll-free case intake line at 1-877-777-4778 or TTY/TDD 1-800-829-4059.

Protect yourself from suspicious emails or phishing schemes. Phishing is the creation and use of email and websites designed to mimic legitimate business emails and websites. The most common act is sending an email to a user falsely claiming to be an established legitimate enterprise in an attempt to scam the user into surrendering private information that will be used for identity theft.

The IRS does not initiate contacts with taxpayers via emails. Also, the IRS does not request personal detailed information through email or ask taxpayers for the PIN numbers, passwords, or similar secret access information for their credit card, bank, or other financial accounts.

If you receive an unsolicited email claiming to be from the IRS, forward this message to phishing@irs.gov. You may also report misuse of the IRS name, logo, or other IRS property to the Treasury Inspector General for Tax Administration (TIGTA) at 1-800-366-4484. You can forward suspicious emails to the Federal Trade Commission at spam@uce.gov or report them at www.ftc.gov/complaint. You can contact the FTC at www.ftc.gov/idtheft or 877-IDTHEFT (877-438-4338). If you have been the victim of identity theft, see www.IdentityTheft.gov and Pub. 5027.

Visit www.irs.gov/IdentityTheft to learn more about identity theft and how to reduce your risk.

Privacy Act Notice

Section 6109 of the Internal Revenue Code requires you to provide your correct TIN to persons (including federal agencies) who are required to file information returns with the IRS to report interest, dividends, or certain other income paid to you; mortgage interest you paid; the acquisition or abandonment of secured property; the cancellation of debt; or contributions you made to an IRA, Archer MSA, or HSA. The person collecting this form uses the information on the form to file information returns with the IRS, reporting the above information. Routine uses of this information include giving it to the Department of Justice for civil and criminal litigation and to cities, states, the District of Columbia, and U.S. commonwealths and possessions for use in administering their laws. The information also may be disclosed to other countries under a treaty, to federal and state agencies to enforce civil and criminal laws, or to federal law enforcement and intelligence agencies to combat terrorism. You must provide your TIN whether or not you are required to file a tax return. Under section 3406, payers must generally withhold a percentage of taxable interest, dividend, and certain other payments to a payee who does not give a TIN to the payer. Certain penalties may also apply for providing false or fraudulent information.

Initial Page: _____ Owner _____ Contractor

INSURANCE REQUIREMENTS

SECTION 1: DEFINITIONS

"**Location**" means the location subject of the Subcontract/Purchase Order.

"**Project**" means the project subject of the Subcontract/Purchase Order.

"**Scope**" means the scope of work to be provided by the Subcontractor under the Contract or the Goods and Services to be supplied and performed by Seller under the Purchase Order, as applicable.

"**State**" means a state of the United States or the District of Columbia or the Commonwealth of Puerto Rico, as applicable

"**Alternate/ Leased Employer Endorsement**" is an endorsement added to a workers compensation policy that provides an entity scheduled as an alternate employer with primary workers compensation and employers liability coverage as if it were an insured under the policy. This endorsement is commonly used when a temporary help agency (the insured) is required by its customer (the alternate employer) to protect the alternate employer from claims brought by the insured's employees.

SECTION 2: STANDARD INSURANCE COVERAGES

Successful Bidder' shall comply with the following:

1. Unless higher limits or additional coverages are required by the Contract/Purchase Order or Owner Contract, the Successful Bidder' shall secure and maintain the minimum from the earlier commencement of work or the effective date of the Contract/Purchase Order insurance coverages and limits required by this Exhibit A.
2. Failure of the Contractor/Buyer to identify deficiencies in any insurance provided by Successful Bidder' shall not relieve Successful Bidder' from any insurance obligations. Required coverages are as follows:

2.1. Commercial General Liability Insurance Coverages:

Commercial General Liability insurance using ISO's CG 00 01 or its substantial equivalent with **City of Panama City Beach** as an additional insured using ISO's CG 20 10 or its substantial equivalent for ongoing operations and ISO's CG 20 37 or its substantial equivalent for completed operations with the following minimum limits:

- \$1,000,000 Each Occurrence
- \$1,000,000 Personal and Advertising Injury
- \$2,000,000 General Aggregate
- \$2,000,000 Products-Completed Operations Limit
- \$500,000 Damage to Rented Premises

Per Project using ISO's CG 25 04 or its substantial equivalent

Initial Page: _____ Owner _____ Contractor

The Successful Bidder' must disclose to **City of Panama City Beach** any endorsements that limit or exclude coverage customarily provided by ISO's CG 00 01.

The Successful Bidder''s Commercial General Liability policy shall not contain an exclusion or restriction of coverage for the following:

1. Claims by one insured against another insured, if the exclusion or restriction is based solely on the fact that the claimant is an insured, and there would otherwise be coverage for the claim.
2. Claims for property damage to the Successful Bidder''s Work arising out of the products-completed operations hazard where a Subcontractor performed the damaged Work or the Work out of which the damage occurs.
3. Claims for bodily injury other than to employees of the insured.
4. Claims for indemnity arising out of injury to employees of the insured.
5. Claims or loss excluded under a prior work endorsement or other similar exclusionary language.
6. Claims or loss due to physical damage under a prior injury endorsement or similar exclusionary language.
7. Claims related to residential, multi-family, or other habitational projects if the work is to be performed on such a project.
8. Claims related to roofing, if the work involves roofing.
9. Claims related to exterior insulation finish systems (EIFS), synthetic stucco, or similar exterior coatings or surfaces if the work involves such coatings or surfaces.
10. Claims related to earth subsidence or movement, where the work involves such hazards.
11. Claims related to explosion, collapse, and underground hazards, where the work involves such hazards.

The Successful Bidder's Commercial General Liability insurance will remain in force with annual policy periods for the period of the statute of repose applicable to this project. *Alternatively, suppose a "project-specific" General Liability policy is used to satisfy these requirements. In that case, it must be endorsed to provide extended completed operations for the period of the statute of repose applicable to this project.*

2.2. Workers Compensation

Worker's Compensation Insurance and Employer's Liability Insurance (including occupational disease) to cover statutory benefits and limits under the Worker's Compensation laws of any applicable jurisdiction in which the Scope is to be performed and minimum limits.

- **Bodily Injury by Accident - \$100,000 Each Accident**
- **Bodily Injury by Disease - \$500,000 Policy Limit**
- **Bodily Injury by Disease - \$100,000 Each Employee**

Policy coverage terms and conditions to include:

- USL&H – where applicable.
- Jones Act – where applicable.
- All State's endorsement – where applicable.
- Employers Liability/Stop Gap Liability if work is performed in Washington, Wyoming, Ohio, North Dakota, or the Commonwealth of Puerto Rico.

Initial Page: _____ Owner _____ Contractor

- For the attainment of Workers Compensation in monopolistic states and Puerto Rico, coverage must be secured through the state fund of that State.
- The certificate must identify that coverage applies in the State where the Project is located.

2.3. Automobile Liability

Commercial Automobile Liability insurance covers all owned, leased, and non-owned vehicles used in connection with the Scope. Business Auto Coverage Form using ISO's CA 00 01 or its substantial equivalent including liability coverage for all autos owned (Symbol 1), rented, hired, or borrowed by the contractors, as well as liability coverage for mobile equipment subject to compulsory insurance or financial responsibility laws or other motor vehicle insurance laws with the following minimum limit:

- **\$1,000,000 – Any One Accident – Combined Single Limit**

Suppose the Contractor/Sub-Contractor/Vendor is responsible for removing any pollutants from a site. In that case, the Successful Bidder' will need to cover its automobile exposure for transporting the pollutants from the site to an approved disposal site. Therefore, auto liability coverage should be endorsed to include the required auto pollution endorsements and Motor Carrier Act Endorsement, MCS 90, and the ISO Form CA 9948 (Pollution Liability Broadened Coverage for Business Automobile).

2.4. Umbrella or Excess Liability Required: **Yes**

Also, the Successful Bidder' shall provide an umbrella or excess liability insurance providing in excess of the underlying Commercial General Liability, Business Automobile Liability, Pollution Liability (if required), and Employers' Liability insurance above, with the following minimum limits:

- **\$1,000,000 Each Occurrence**
- **\$1,000,000 Annual Aggregate** (where applicable in the underlying)

Such umbrella or excess liability policy shall provide substantially the same coverage as the underlying Commercial General Liability (including **City of Panama City Beach** as additional insured), Business Automobile Liability, Pollution Liability, and Employers' Liability insurance. In addition, it shall expressly provide that the umbrella or excess policy will drop down over the underlying insurance's reduced or exhausted aggregate limit. The umbrella or excess policy shall also be primary insurance to **City of Panama City Beach**(including primary insurance to **City of Panama City Beach's** own Commercial General Liability and Umbrella policies), and Successful Bidder's umbrella insurer agrees not to seek contribution from **City of Panama City Beach** insurance.

2.5. Professional Liability Required: **No**

Professional Liability Insurance is required to cover liability for claims that arise from the errors, omissions, or acts of the Successful Bidder' or any entity the Successful Bidder' is legally responsible in the provision of professional services. The policy shall be primary and non-contributory, with the insuring agreement to read: "to pay on behalf of" and shall be effective (retroactively, if applicable) from the commencement date of all professional activities in connection with the Scope. The coverage shall be maintained for three years following the final acceptance of the Project.

Initial Page: _____ Owner _____ Contractor

Minimum limits are:

- **Prime Design Professional: Choose limits when required per claim/annual aggregate;**
- **Sub-Design Professional: Choose limits when required per claim/annual aggregate.**

Upon request, a copy of the policy shall be provided to **City of Panama City Beach**. Coverages shall not include any exclusions or other limitations related to the scope of the services, delays in project completion, or cost overruns.

For Professional Liability Insurance, the term "Prime Design Professional" means the architect and/or engineer providing architectural, engineering, and/or other professional services under a contract directly with our company. The term "Sub-Design Professional" means any architect and/or engineer providing architectural, engineering, and/or other professional services directly or indirectly to a Prime Design Professional in connection with the project. A Prime Design Professional is also a Contractor/Subcontractor, and a Sub-Design Professional is also a Sub-subcontractor.

2.6 Riggers Liability Required: **No**

If marked as required, the Scope involves the rigging, hoisting, lowering, raising, or moving of property or equipment belonging to others. Riggers Liability Insurance is required to insure against physical loss or damage to the property or equipment.

2.8 Aircraft/Watercraft: Required: **No**

If marked as required, the Scope involves using any owned, leased, chartered, or hired aircraft or watercraft of any type. As applicable, Aircraft Liability Insurance or Watercraft Liability Insurances required in an amount of not less than **Choose limits when required** per occurrence, including Passenger Liability for bodily injury and property damage.

2.9 Property Insurance:

Property Insurance coverage for tools and equipment owned, leased, or used by the Subcontractor/Seller in the performance of the Scope. The Property Insurance shall extend to equipment, materials, and supplies stored off the Project site or in transit to the Project site to be furnished as part of the Scope and incorporated into the Project.

2.9.1 Herbicide & Pesticide Application Insurance: Required: **Yes**

Successful Bidder' shall secure and maintain the minimum Herbicide & Pesticide Application Insurance coverage and limits required by this Exhibit A from the effective date of the Contract/Purchase Order until the end of the applicable warranty period. The policy shall be submitted to the Contractor/Buyer for review and approval before commencement of the Scope. Failure of the Contractor/Buyer to identify deficiencies in the Herbicide & Pesticide Application Insurance provided by Subcontractor/Vendor shall not relieve Subcontractor/Vendor from any obligations.

Minimum limits are: Including Cleanup Cost

- **\$1,000,000.00 per occurrence or claim**
- **\$2,000,000.00 policy aggregate.**

Initial Page: _____ Owner _____ Contractor

The coverage shall be as follows: Subcontractor shall provide Herbicide & Pesticide Application Insurance. If the policy contains a general aggregate, this aggregate must apply on a per-project basis and shall be evidenced on Subcontractor's/Vendors Certificate of Insurance. The limits shall not be subject to reduction as to the Contractor/Buyer or Owner because of any claim asserted against the Subcontractor/Vendor other than in connection with the Scope. Instead of indemnifying, the policy must read "to pay on behalf of." In addition, the following coverages must be included: (1) Completed Operations (five (5) year continuation beyond completion of the Scope); (2) Broad Form Contractual and Independent Contractors (including coverage for third party over claims); (3) On-Site, Off-Site and In-Transit exposures; and (4) Loading and Unloading. Exclusions or restrictions pertaining to mold and EIFS are not permitted. The coverage may be written on an "occurrence" or "claims made" basis. If written on a "claims made" basis, the retroactive date must be included to coincide with the effective date of the Subcontract/Purchase Order, and an extended reporting period (three (3) years minimum) must be included.

The coverage may be written on an "occurrence" or "claims made" basis. If written on a "claims made" basis, the retroactive date must be included to coincide with the effective date of the Subcontract/Purchase Order, and an extended reporting period (three (3) years minimum) must be included.

Deductibles/Denial of Claims:

Contractor/Vendor shall be responsible, at no additional cost to Contractor/Buyer, for the payment of any deductibles or self-insured retention in connection with the insurance coverages required by this Exhibit A both for itself and all Additional Insureds. Any self-insured retention or deductible in excess of \$25,000 must be declared when Subcontractor/Seller submits its bid and must be approved explicitly by Contractor/Buyer before executing the Subcontract/Purchase Order. Subcontractor/Seller shall be responsible for any loss arising from coverage denial by its insurance carrier.

Leased Successful Bidder' Employee Liability

If the leases one or more employees through the use of a payroll, employee management, or other company, the Successful Bidder' must directly procure workers compensation/employer's liability insurance. The insurance shall be written on a "Minimum Premium" or "If Any" policy form.

In addition, the worker's compensation/employer's liability coverage provided to and for the leased employees by the payroll, employee management, or other company must be evidenced and include an Alternate / Leased Employer Endorsement or its substantial equivalent WC endorsement for that State, naming Successful Bidder' as the alternate employer.

Insurer Requirements

Each insurer providing insurance coverage as required by this contract shall be a licensed admitted insurer authorized to issue such coverages in each State in which any part of the Scope is performed. The insurer shall be acceptable to **City of Panama City Beach** and have an AM Best rating of "A-" or better.

Before accepting the Contractor/Sub-Contractor/Vendor's bid, City of Panama City Beach reserves the right to require more significant limits based on the nature of the operations performed by the Successful Bidder'.

Initial Page: _____ Owner _____ Contractor

Certificate of Insurance

Before commencing its performance and throughout the warranty period under the Contract /Purchase Order, the Successful Bidder' shall provide **City of Panama City Beach** a current certificate of insurance evidencing the coverages required by this contract (a sample Certificate of Insurance is attached for reference purposes).

Sub-subcontractor/Sub-Vendor

Before permitting any lower tier Sub-subcontractor/Sub-vendor to perform Scope under the Contract/Purchase Order, the Successful Bidder' shall require its sub-subcontractor/Sub-vendor to maintain insurance in like form and amounts to that required herein. Successful Bidder' shall be responsible for ensuring that its sub-subcontractor/Sub-vendor maintains insurance in like form and amounts and shall provide evidence of same to **City of Panama City Beach** if requested.

Any subcontractors engaged by the Contractor shall comply with the above requirements. Consideration for specific trades can be made with prior approval.

Notice of Cancellation

All insurance coverages required by this contract shall contain a provision that the coverage afforded hereunder cannot be canceled, non-renewed, allowed to lapse, or have any restricted modifications added unless at least thirty (30) days prior written notice has been given to **City of Panama City Beach**

Additional Insureds

All insurance required by this contract (excluding only Workers Compensation Insurance and Professional Liability Insurance) shall name the City of Panama City Beach and its officials, employees, and volunteers as Additional Insureds and any other parties as required by the Owner Contract, and shall be primary and non-contributory to any insurance maintained by Indemnified Parties and Additional Insureds and any other parties as required by Owner Contract, all of which shall be stated on the Certificate of Insurance provided by the Successful Bidder'.

The General Liability Additional Insured Endorsement shall use ISO's or CG 2010 or its substantial equivalent for ongoing operations and ISO's CG 20 37 or its substantial equivalent for completed operations. By endorsement or policy language, evidence of Additional Insured and Primary and Non-Contributory coverage must be provided with the certificate of insurance for General Liability. The Successful Bidder's insurers will provide insurance to **City of Panama City Beach**, on a primary basis and agree not to seek contribution from insurance by using ISO's CG 20 01 or its substantial equivalent. Successful Bidder's insurers also agree to waive rights of subrogation against **City of Panama City Beach** using ISO's CG 24 04 or its substantial equivalent.

Waiver of Subrogation

All insurance coverages maintained by Successful Bidder' shall include a waiver of any right of subrogation of the insurers thereunder against Indemnified Parties and Additional Insureds and all of their respective assigns, subsidiaries, affiliates, employees, insurers, and underwriters, and of any right of the insurers to any set-off or counterclaim or any other deduction, whether by attachment or otherwise, in respect of any liability of any person insured under any such policy (Workers Compensation – where permitted).

The Successful Bidder' further waives all claims and all rights of subrogation against Indemnified Parties' and Additional Insureds' other contractors and all of their respective assigns, subsidiaries, affiliates, employees, insurers, and underwriters for loss of, or damage to, contractors Scope, tools, machinery, equipment, material, supplies, or any other losses within the scope of any insurance maintained by **City of Panama City Beach**. If any of the Indemnified Parties and Additional Insureds are partially or wholly self-insured, then the waiver of subrogation shall apply as if their insurance covered them.

Initial Page: _____ Owner _____ Contractor

Insurance Policy Review/Exclusions/Copies

City of Panama City Beach, can receive copies of all insurance policies upon request. Policies shall not contain any exclusions that are unacceptable to **City of Panama City Beach**. If requested by **City of Panama City Beach**, all insurance carriers must certify all policies as accurate and complete. At their sole discretion, policies shall not contain any unacceptable exclusions to **City of Panama City Beach**. **City of Panama City Beach**'s right to review and approve all insurance policies will not constitute a waiver of any rights created by or provisions contained in this contract should they differ from those contained in such policies.

Claims-Made Policies

Except for Professional Liability Insurance, claims-made policies are not acceptable.

Effect of Specified Coverages

The Insurance obligations under this agreement shall be 1—all the Insurance coverage and/or limits carried by or available to the Contractor; or 2—the minimum Insurance coverage requirements and/or limits shown in this agreement, whichever is greater. Any insurance proceeds in excess of or broader than the minimum required coverage and/or minimum required limits, which apply to a given loss, shall be available to **City of Panama City Beach**. No representation is made that this agreement's minimum insurance requirements are sufficient to cover the Contractor's obligations under this agreement.

Breach of Insurance Requirements

Successful Bidder's failure to obtain and maintain insurance coverages as required by this Exhibit A or any other Exhibit or attachment shall constitute a material breach of the Contract/Purchase Order. In such event, in addition to any other rights and remedies contained in the Contract/Purchase Order, (i) **City of Panama City Beach** may, at its option, terminate the contract for default; (ii) **City of Panama City Beach** may, at its option, purchase such coverage and back charge the premium and associated costs to Successful Bidder'; and/or (iii) any of the Indemnified Parties, or Additional Insureds can require, that contractor and/or its subcontractors to pay for all attorney's fees, expenses, and liability as a result of any claim or lawsuit for which coverage would have been provided to the Indemnified Parties or Additional Insureds under contractors insurance program but for a breach by Contractor or any of its subcontractors.

Furthermore, to the extent of their respective interests, the Insurers of those entities that were to be included as Additional Insureds are deemed third-party beneficiaries of the insurance procurement obligation and have the same rights against the breaching party as the Indemnified Parties or Additional Insureds.

If any of the preceding insurance coverages are required to remain in force after final payment and are reasonably available, an additional certificate evidencing continuation of such coverage shall be submitted with the final application for payment as required. If the insurer does not furnish any information concerning the reduction of coverage, it shall be furnished by the contract with reasonable promptness according to the Successful Bidder's information and belief. Suppose Successful Bidder' fails to maintain insurance. **City of Panama City Beach** may (at its sole option) terminate the Successful Bidder' or place such insurance and deduct any cost, fees, and related expenses from Successful Bidder' pay request.

Any Successful Bidder' engaged by the Contractor shall comply with the above requirements. Consideration for specific trades can be made with prior approval.

City of Panama City Beach

Endorsements to be attached:

General Liability	Endorsement #	Edition Dates	Carrier	Policy #'s to be listed
Added Insured - Ongoing Operations	CG 20 10	All	ISO Standard or Equal	Yes
Added Insured – Completed Operations	CG 20 37	All	ISO Standard	Yes
Waiver of Subrogation	CG 24 04		ISO Standard	
Primary & Non-Contributory	CG 20 01		ISO Standard	
Automobile Liability				
No Endorsements Required				
Umbrella or Excess Liability				
List all lines this policy applies.				
Workers Compensation				
Waivers of Subrogation	WC 00 03 13		ISO Standard	Yes
Alternate Employer Endorsement	WC 00 03 01 A		ISO Standard	Yes

* State Waiver of Subrogation Provisions Overview: Kansas, Kentucky, Missouri, New Hampshire, and New Jersey disallow waivers of subrogation by statute. However, only Kansas and Missouri bar waivers of subrogation in the construction industry. (Note that Kansas does not prohibit the use of waivers of subrogation for consolidated or wrap-up insurance programs.) The monopolistic states either disallow waivers of subrogation or allow the state fund to make that decision. The remaining states allow for waivers of subrogation through judicial interpretation or administrative rules.

*Stop Gap endorsement required in monopolistic states such as ND, OH, WA WY, or Puerto Rico

*Coverage must apply in the State where the work is being performed if the vendor is from a state other than the one where the project is located.

We accept endorsements that are equal to those requested. Most insurance company forms are manuscript; therefore, they might not be compliant (most are not). We review all forms during the review process. Forms that are compliant today may not be compliant tomorrow. Our decisions are based on case law and claim history. Additional Insured or Organization Name to be listed on all endorsements along with policy numbers as applicable. Blank endorsements will not be excepted. Sample Endorsements Attached

Blanket Certificates of Insurance

For ease of paperwork, subcontractors may submit insurance documentation on a blanket basis to work on multiple projects under just one insurance certificate. (View sample certificate above or in compliance database)

Subcontractor performing work on multiple projects in the same State

Each of our projects requires a project-specific certificate of insurance (COI) for EACH project they work on; however, a lot of our Subcontractors are doing multiple projects in one State, which creates an opportunity to reduce paperwork by providing a blanket certificate of insurance and allowing the Subcontractor to work on all projects (Non-OCIP or CCIP) under one COI. If providing a blanket certificate, the following guidelines will be in addition:

1. On the COI, instead of stating an individual project name, replace with the following verbiage in the Description of Operations section of the certificate: **"All projects performed for City of Panama City Beach**
2. When stating the additional insureds, state the following along with the other required Description of Operations wording: "All insurance (excluding Workers Compensation and Professional Liability) include Owner, City of Panama City Beach, Indemnified Parties, any other parties as required by Owner Contract and their respective directors, officers, employees, and affiliates as Additional Insureds, and shall be primary and non-contributory to any insurance maintained by Additional Insureds."
3. All endorsements and waivers must be blanket-based, either per form or blanket wording. For example, a contract requires endorsements/waivers in such schedules instead of listing each entity.

Commercial General Liability

CG 20 10 10 01

POLICY NUMBER: **Required**

COMMERCIAL GENERAL LIABILITY
CG 20 10 10 01

THIS ENDORSEMENT CHANGES THE POLICY. PLEASE READ IT CAREFULLY.

ADDITIONAL INSURED – OWNERS, LESSEES OR CONTRACTORS – SCHEDULED PERSON OR ORGANIZATION

This endorsement modifies insurance provided under the following:

COMMERCIAL GENERAL LIABILITY COVERAGE PART

SCHEDULE

Name of Person or Organization:

Certificate Holders Name

(If no entry appears above, information required to complete this endorsement will be shown in the Declarations as applicable to this endorsement.)

A. Section II – Who Is An Insured is amended to include as an insured the person or organization shown in the Schedule, but only with respect to liability arising out of your ongoing operations performed for that insured.

B. With respect to the insurance afforded to these additional insureds, the following exclusion is added:

2. Exclusions

This insurance does not apply to "bodily injury" or "property damage" occurring after:

- (1) All work, including materials, parts or equipment furnished in connection with such work, on the project (other than service, maintenance or repairs) to be performed by or on behalf of the additional insured(s) at the site of the covered operations has been completed; or
- (2) That portion of "your work" out of which the injury or damage arises has been put to its intended use by any person or organization other than another contractor or subcontractor engaged in performing operations for a principal as a part of the same project.

CG 20 10 10 01

© ISO Properties, Inc., 2000

Page 1 of 1

CG 20 37 10 01

POLICY NUMBER: **Required**

COMMERCIAL GENERAL LIABILITY
CG 20 37 10 01

THIS ENDORSEMENT CHANGES THE POLICY. PLEASE READ IT CAREFULLY.

ADDITIONAL INSURED – OWNERS, LESSEES OR CONTRACTORS – COMPLETED OPERATIONS

This endorsement modifies insurance provided under the following:

COMMERCIAL GENERAL LIABILITY COVERAGE PART

SCHEDULE

Name of Person or Organization:

Certificate Holders Name

Location And Description of Completed Operations:

All locations required by contract

Additional Premium:

(If no entry appears above, information required to complete this endorsement will be shown in the Declarations as applicable to this endorsement.)

Section II – Who Is An Insured is amended to include as an insured the person or organization shown in the Schedule, but only with respect to liability arising out of "your work" at the location designated and described in the schedule of this endorsement performed for that insured and included in the "products-completed operations hazard".

CG 20 37 10 01

© ISO Properties, Inc., 2000

Page 1 of 1

CG 24 04 05 09

POLICY NUMBER: **Required**

COMMERCIAL GENERAL LIABILITY
CG 24 04 05 09

WAIVER OF TRANSFER OF RIGHTS OF RECOVERY AGAINST OTHERS TO US

This endorsement modifies insurance provided under the following:

COMMERCIAL GENERAL LIABILITY COVERAGE PART
PRODUCTS/COMPLETED OPERATIONS LIABILITY COVERAGE PART

SCHEDULE

Name Of Person Or Organization:

Certificate Holders Name

Information required to complete this Schedule, if not shown above, will be shown in the Declarations.

The following is added to Paragraph 8. **Transfer Of Rights Of Recovery Against Others To Us** of Section IV – Conditions:

We waive any right of recovery we may have against the person or organization shown in the Schedule above because of payments we make for injury or damage arising out of your ongoing operations or "your work" done under a contract with that person or organization and included in the "products-completed operations hazard". This waiver applies only to the person or organization shown in the Schedule above.

CG 24 04 05 09

© Insurance Services Office, Inc., 2008

Page 1 of 1

CG 20 01 04 13

COMMERCIAL GENERAL LIABILITY
CG 20 01 04 13

THIS ENDORSEMENT CHANGES THE POLICY. PLEASE READ IT CAREFULLY.

PRIMARY AND NONCONTRIBUTORY – OTHER INSURANCE CONDITION

This endorsement modifies insurance provided under the following:

COMMERCIAL GENERAL LIABILITY COVERAGE PART
PRODUCTS/COMPLETED OPERATIONS LIABILITY COVERAGE PART

The following is added to the **Other Insurance** Condition and supersedes any provision to the contrary:

Primary And Noncontributory Insurance

This insurance is primary to and will not seek contribution from any other insurance available to an additional insured under your policy provided that:

- (1) The additional insured is a Named Insured under such other insurance; and

- (2) You have agreed in writing in a contract or agreement that this insurance would be primary and would not seek contribution from any other insurance available to the additional insured.

CG 20 01 04 13

© Insurance Services Office, Inc., 2012

Page 1 of 1

Workers Compensation

WC 00 03 13

WORKERS COMPENSATION AND EMPLOYERS LIABILITY INSURANCE POLICY WC 00 03 13
(Ed. 4-84)

WAIVER OF OUR RIGHT TO RECOVER FROM OTHERS ENDORSEMENT

We have the right to recover our payments from anyone liable for an injury covered by this policy. We will not enforce our right against the person or organization named in the Schedule. (This agreement applies only to the extent that you perform work under a written contract that requires you to obtain this agreement from us.)

This agreement shall not operate directly or indirectly to benefit anyone not named in the Schedule.

Schedule

In Favor of:

Certificate Holders Name and Project Owner

Work Performed by:

Client (Our Subcontractor)

Client Address

On the Following Project or Location

All Projects or Locations as Required by Contract

This endorsement changes the policy to which it is attached and is effective on the date issued unless otherwise stated.

(The information below is required only when this endorsement is issued subsequent to preparation of the policy.)

Endorsement Insured	Effective Policy No. Required	Endorsement No. Premium
Required		
Insurance Company	Countersigned by _____	
Required		

WC 00 03 13
(Ed. 4-84)

WC 00 03 01 A

WORKERS COMPENSATION AND EMPLOYERS LIABILITY INSURANCE POLICY WC 00 03 01 A
(Ed. 2-89)

ALTERNATE EMPLOYER ENDORSEMENT

This endorsement applies only with respect to bodily injury to your employees while in the course of special or temporary employment by the alternate employer in the state named in Item 2 of the Schedule. Part One (Workers Compensation Insurance) and Part Two (Employers Liability Insurance) will apply as though the alternate employer is insured. If an entry is shown in Item 3 of the Schedule the insurance afforded by this endorsement applies only to work you perform under the contract or at the project named in the Schedule.

Under Part One (Workers Compensation Insurance) we will reimburse the alternate employer for the benefits required by the workers compensation law if we are not permitted to pay the benefits directly to the persons entitled to them.

The insurance afforded by this endorsement is not intended to satisfy the alternate employer's duty to secure its obligations under the workers compensation law. We will not file evidence of this insurance on behalf of the alternate employer with any government agency.

We will not ask any other insurer of the alternate employer to share with us a loss covered by this endorsement.

Premium will be charged for your employees while in the course of special or temporary employment by the alternate employer.

The policy may be canceled according to its terms without sending notice to the alternate employer.

Part Four (Your Duties If Injury Occurs) applies to you and the alternate employer. The alternate employer will recognize our right to defend under Parts One and Two and our right to inspect under Part Six.

Schedule

- | | |
|---|--|
| 1. Alternate Employer
Our Subcontractor - Not the PEO | Address
Our Subcontractors Address |
| 2. State of Special or Temporary Employment
All Applicable States | |
| 3. Contract or Project
All Locations or Projects Required by Contract | |

This endorsement changes the policy to which it is attached and is effective on the date issued unless otherwise stated.

(The information below is required only when this endorsement is issued subsequent to preparation of the policy.)

Endorsement Effective Date Here is Required	Policy No. Policy Number Required	Endorsement No. Premium \$
Insured Required		
Insurance Company	Countersigned by _____	
Required		

WC 00 03 01 A
(Ed 2-89)

PCB24-12 ITB LANDSCAPING MAINTENANCE SERVICES
CITY MAIN CAMPUS FY2024



CITY OF PANAMA CITY BEACH

**PCB24-12 ITB LANDSCAPING MAINTENANCE SERVICES
CITY MAIN CAMPUS FY2024**

INFORMATIONAL EXHIBITS

PCB24-12 ITB LANDSCAPING MAINTENANCE SERVICES
CITY MAIN CAMPUS FY2024

NOTICE OF AWARD

TO: _____

PRODUCT DESCRIPTION:

**PCB24-12 LANDSCAPING MAINTENANCE SERVICES
CITY MAIN CAMPUS**

The City of Panama City Beach ("City") has considered the BID submitted by you for the above-described Services in response to its Advertisement for Bids dated _____, 20____, and associated Information for Bidders.

You are hereby notified that your pricing schedule has been accepted by the City.

Annual Rate: \$ _____ = \$ _____ (monthly)

Provided, however, nothing in this Notice or your delivery to the City of the Agreement executed by you shall in any manner or way be deemed to create any contract between you and the City. No such contract shall be created unless and until the City signs the Agreement.

You are required by the Information for Bidders to execute this Agreement.

If you fail to execute said Agreement within ten (10) calendar days from the date of this Notice, City will be entitled to consider all your rights arising out of the City's acceptance of your BID abandoned.

You must return an acknowledged copy of this Notice of Award to the City, with the executed Agreement and required Certificates of Insurance and Bonds, within the above noted ten (10) calendar day period.

Dated this _____ day of _____, 20 _____.

[REMAINDER OF THIS PAGE INTENTIONALLY LEFT BLANK.]

PCB24-12 ITB LANDSCAPING MAINTENANCE SERVICES
CITY MAIN CAMPUS FY2024

CITY OF PANAMA CITY BEACH
Owner

By _____

Name: Drew Whitman

Title: City Manager

ACCEPTANCE OF NOTICE

Receipt of the above Notice of Award is hereby acknowledged:

By _____

This the _____ day of _____, 20__.

Name _____

Title _____

[END OF NOTICE OF AWARD]

AGREEMENT

LANDSCAPING MAINTENANCE SERVICES

THIS LANDSCAPING MAINTENANCE SERVICES CITY MAIN CAMPUS FY2024 AGREEMENT is made and entered into this _____ day of _____, 2024, by and between the **CITY OF PANAMA CITY BEACH, FLORIDA**, a municipal corporation (City) and _____ (Contractor).

PREMISES

1. SCOPE OF WORK

Contractor will provide annual Landscape Maintenance Services, as more particularly described in the Specifications listed in Invitation to Bid number PCB24-12.

If the Contractor believes that any particular service is not within the scope of the contract, is a material change, or will otherwise require more compensation to the Contractor, the Contractor must immediately notify the City's Representative in writing of this belief. If the City's Representative believes that the particular service is within the scope of the contract as written, the Contractor will be ordered to and shall continue to supply the service as changed and at the cost stated for the work/service within the scope. The Contractor must assert its right to an adjustment under this clause within thirty (30) days from the date of the receipt of this agreement.

2. COMPENSATION

As compensation for supplying the services contemplated herein and performance rendered by the Contractor of its duties and obligations hereunder, City shall pay Contractor according to the not to exceed bid unit prices submitted on PCB24-12 ITB LANDSCAPING MAINTENANCE SERVICES CITY MAIN CAMPUS. The City shall pay to the Contractor as full consideration for the services required by this Agreement, at the UNIT PRICE contained in the Contractor's cost proposal, upon the basis of actual measured quantities as the same may be finally determined by the City Manager or his/her designee(s).

A. Extra and/or Additional Work Changes – Should City at any time during the progress of said work request alterations, deviations, additions, or omissions from said specifications or other contract documents, it shall be at liberty to do so by written authorization to Contractor, and the same shall in no way affect or make void the Agreement. The unit price of any such addition or deletion from the contract Bid price, must be mutually agreed upon by both parties.

3. PAYMENT

Contractor will invoice for payment to the City when satisfactory inspection of requested/scheduled WORK has been completed. The invoice(s) shall be delivered to accounts payable at City Hall, 17007 Panama City Beach Parkway, Panama City Beach, Florida 32413. Payment to Contractor shall be made via ACH or Virtual Credit Card.

4. TERM

Unless terminated sooner pursuant to the provision of the Termination clauses contained in paragraph 6, and subject to the availability of funds appropriated for this purpose, this Agreement shall take effect on the executed date of award and be valid for a period of one (2) years with an option to renew for two (2) additional one (1) year terms.

5. PRICE ADJUSTMENTS

- A. Increases – After the first year of the contract, Contractor may request a price increase adjustment no more than two times in any following contract year. In the event Contractor desires to increase price, City must be notified immediately. Price increases must be approved by City and no payment for additional materials or services, beyond the amount stipulated in the Contract shall be paid without prior approval. All price increases must be supported by Producer Price Index or manufacturer documentation and justification. Contractor must honor previous prices for thirty (30) days after approval and written notification from City. It is the Contractor's responsibility to keep all pricing up to date and on file with City. All price changes must be provided to City using the same format as was provided and accepted in the Contractor's proposal.
- B. Reductions – Price reductions may be offered at any time during Contract. City may request a price reduction, which Contractor shall permit, when such a request is supported by Producer Price Index.

6. TERMINATION OF CONTRACT

- A. City Termination for Cause – The Agreement may be terminated by the City for cause in the event of any breach hereof, including, but not limited to, Contractor's: (1) failing to carry forward and complete the Work as provided herein; (2) failing to comply with applicable laws, regulations, permits, or ordinances; (3) failing to timely correct defective Work; (4) making a general assignment for the benefit of its creditors; (5) having a receiver appointed because of insolvency; (6) filing bankruptcy or having a petition for involuntary bankruptcy filed against it; (7) failing to make payments when due to subcontractors, vendors, or others for materials or labor used in the Work; (8) making a material misrepresentation to the City regarding the Work; (9) arrest or conviction of felony or fraud, or (10) any other material breach of this Agreement. In such event, the City shall provide Contractor with written notice of its intention to terminate this Agreement, stating the nature of the deficiency and the effective date of termination. At the City's sole judgement and discretion, the City may afford Contractor an opportunity to cure said deficiency, in which event the notice shall specify the time allowed. Upon termination, the City may take possession of the premises and of all materials thereon and finish the Work by whatever means it seems expedient.
- B. City Termination for Convenience – Notwithstanding any other provision hereof, the City may at any time terminate this Agreement or any Work

issued under it, in whole or in part, without cause, upon thirty (30) days advanced written notice to Contractor. In such event, Contractor shall be compensated for any Work performed prior to the date of termination and for materials that were ordered prior to receipt of notice of termination that cannot be returned to the vendor, which shall become City property. Upon receipt of notice, Contractor shall discontinue Work on the date and to the extent specified therein and shall place no further orders for materials, equipment, services, or facilities, except as needed to continue any portion of the Work not terminated. Contractor shall also make every reasonable effort to cancel, upon terms satisfactory to the City, all orders or subcontracts related to the terminated Work. Contractor may not claim any compensation not specifically provided herein, including, but not limited to loss of anticipated profits, idle equipment, labor, and facilities; or any additional claims of subcontractors and vendors.

7. COMPLIANCE WITH LAWS

The Contractor shall be responsible to know and to apply all applicable federal and state laws, all local laws, ordinances, rules, regulations, and all orders and decrees of bodies or tribunals having jurisdiction or authority which in any manner affect the work, or which in any way affect the conduct of the work. Contractor shall always observe and comply with all such laws, ordinances, rules, regulations, orders, and decrees. The Contractor shall protect and indemnify the City of Panama City Beach and all its officers, agents, servants, or employees against any claim or liability arising from or based on the violation of any such law, ordinance, rule, regulation, order, or decree caused or committed by Contractor, its representatives, sub-contractors, sub-consultants, professional associates, agents, servants, or employees. Additionally, Contractor shall obtain and maintain at its own expense all licenses and permits to conduct business pursuant to this contract from the federal government, State of Florida, Bay County, or municipalities when legally required, and maintain same in full force and effect during term of the contract.

8. WARRANTY

The Contractor agrees that, unless otherwise specified in the specifications of the invitation to bid, the service furnished as a result of this invitation and award thereto shall be covered by the most favorable commercial warranty the Contractor gives to any customer for comparable services and that the right and remedies provided herein are in addition to and do not limit any rights afforded to the City by any other provision of the invitation/offer.

9. INSURANCE AND INDEMNIFICATION

Contractor shall at its own expense maintain in force during the term of the contract the insurance on policies and insurers acceptable to the City as required by the City's Insurance Requirements as specified in the Required Documents section of the solicitation.

- i. Within thirty (30) days of the date of the Award, and thereafter upon the written request of the City, Contractor shall furnish to the City such certificates of coverage and certified copies of policies pursuant to the City's

Insurance requirements in order to satisfy this provision, the documentation required by this part must be sent to the following address: ATTN: RISK MANAGEMENT DIRECTOR, 17007 Panama City Beach Parkway, Panama City Beach, Florida 32413.

- ii. Regardless of the coverage provided by any insurance, the successful Contractor shall indemnify, save harmless and defend the City, its agents, servants, or employees from and against any and all claims, liability, losses and/or causes of action which may arise from any negligent act or omission of the successful Contractor, its sub-contractors, agents, servants, or employees during the course of performing services or caused by the goods provided pursuant to these Bid documents and/or resultant contract.

If any third-party claim is made against the City that, if sustained, would give rise to indemnification liability of the Contractor under this Agreement, the City shall promptly cause notice of the claim to be delivered to the successful Contractor and shall afford the Contractor and its counsel, at the Contractor's/Vendor's sole expense, the opportunity to join in defending or compromising the claim. The covenants contained in this paragraph shall survive the termination of this Agreement.

10. ATTORNEY'S FEES

In the event of any litigation hereunder, each party shall be responsible for its own attorney's fees and court costs at all trial and appellate levels and at any mediation or arbitration.

11. TIME

Time is of the essence in this Agreement.

12. FORCE MAJEURE

The Contractor's failure or inability to perform the stated scope of work at any time as a result of circumstances beyond its control, such as, but not limited to, war, terrorism, strikes, fires, floods, hurricanes, acts of God, power failures, or damage or destruction of any facility related thereto, shall not be deemed a breach of this Agreement.

13. REMEDIES

In the event of failure of the Contractor to deliver product in accordance with the contract terms and conditions, the City, after due written notice, may procure the products from other sources and hold the Contractor responsible for any resulting additional purchase and administrative costs. This remedy shall be in addition to any other remedies that the City may have. Failure to cure a breach of a material term hereunder within 24-hours of Contractor's receipt of written notice thereof shall entitle the City to terminate this Agreement. All rights and remedies conferred upon the parties in this Agreement shall be cumulative and in addition to those available under the laws of the State of Florida.

14. ASSIGNMENT

This Agreement may be assigned with the consent of the City Council.

15. SEVERABILITY

PCB24-12 ITB LANDSCAPING MAINTENANCE SERVICES CITY MAIN CAMPUS FY2024

In the event any provision of this Agreement shall be held invalid or unenforceable by any court of competent jurisdiction, such holding shall not invalidate or render unenforceable any other provision hereof.

16. CHOICE OF LAW & VENUE

This Agreement shall be governed by the laws of the State of Florida. Any legal proceeding regarding this Agreement shall be brought in the 14th Judicial Circuit in Bay County, Florida.

17. MODIFICATIONS

No modification, amendment, or alteration in the terms or conditions contained herein shall be effective unless contained in a written document prepared with the same or similar formality as this Agreement and executed by the City and Contractor.

18. WAIVER

Failure by the City to enforce any provision of this Agreement shall not be deemed a waiver of the provision or modification of this Agreement. A waiver by the City of any breach of a provision of this Agreement shall not be deemed a waiver of any subsequent breach and shall not be construed to be a modification of the terms and conditions of this Agreement.

19. NOTICES

Any notice required by this Agreement shall be directed to the parties as follows:

A. As to City:

City Representative: Chad Roeder

Title/Position: Construction Project Manager

17007 Panama City Beach Parkway, Panama City Beach, FL 32413

Phone: (850) 233-5100, ext. 2400

B. As to Contractor:

Contract Representative: _____

Title/Position: _____

Email Address: _____

Mailing Address: _____

Phone: _____

20. ENTIRE AGREEMENT

This Agreement, and any exhibits or appendixes attached hereto and incorporated herein, constitutes the entire agreement between parties pertaining to the subject matter hereof,

PCB24-12 ITB LANDSCAPING MAINTENANCE SERVICES CITY MAIN CAMPUS FY2024

and supersedes all prior and contemporaneous agreements, understandings, negotiations, and discussions of the parties, whether oral or written, and there are no representations, warranties, covenants or other agreements among the parties.

The term "Agreement" means and includes the following documents, all of which are incorporated into this Agreement by reference:

- Advertisement for Bids
- Information for Bidders
- Scope of Work/Specifications
- Bid Proposal Form
- Conflict of Interest Statement
- Drug Free Work Place Statement
- Public Entity Crimes Statement
- Non-Collusion Affidavit
- E-Verify
- W9
- Insurance Requirements
- Terms and Conditions
- Notice of Award
- Agreement
- Exhibit A – PCB City Main Campus Map
- Exhibit B – Landscape Plan for Fire Station #31 and Police & Fire Storage
- Exhibit C – Landscape Plan for Fire Station #32
- Any Additional Exhibits or Appendices

ADDENDA (S)

No. _____, dated _____, 20 _____

No. _____, dated _____, 20 _____

No. _____, dated _____, 20 _____

No. _____, dated _____, 20 _____

IN WITNESS WHEREOF, the Contractor has executed this Agreement as of the day and year first written above.

Signed in the presence of: Contractor

Witness 1: _____

(Print Name): _____

By: _____

Contractor

Witness 2: _____

(Print Name): _____

PCB24-12 ITB LANDSCAPING MAINTENANCE SERVICES CITY MAIN CAMPUS FY2024

**THE CITY OF PANAMA CITY
BEACH, FLORIDA,**
a municipal corporation

By: _____
Drew Whitman, City Manager

ATTEST:

City Clerk

EXHIBIT A

“PCB City Main Campus Map”

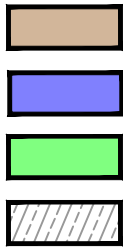

DENOTES
LANDSCAPE AREA

DENOTES
POND AREA

DENOTES AREA
TO BE MOWED

DENOTES AREA TO NOT BE
INCLUDED IN CONTRACT

S.F.

±

DENOTES SQUARE FEET

DENOTES MORE OR LESS

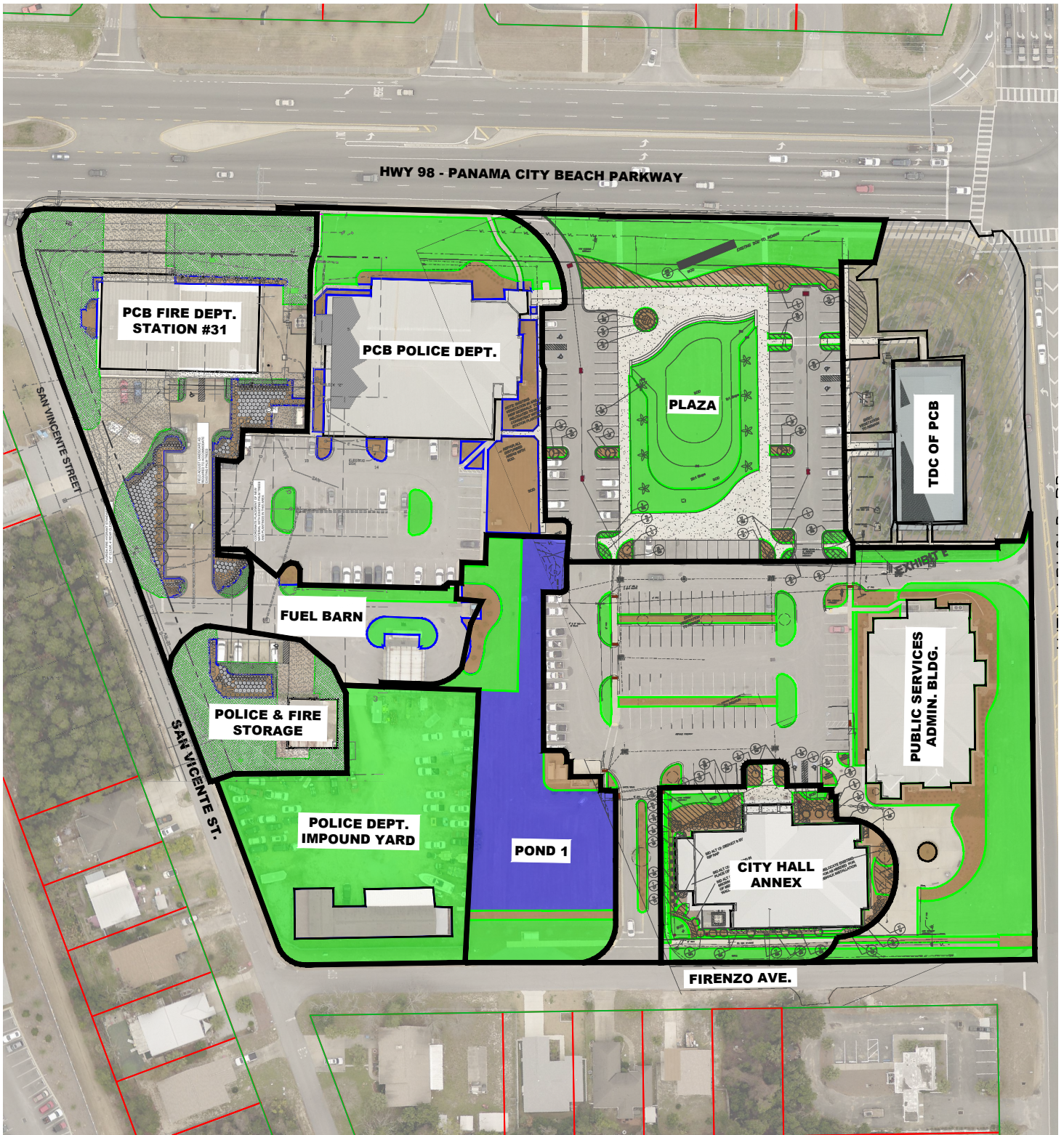

P.C.B. CITY MAIN CAMPUS LANDSCAPING AREAS
± 165,093 S.F. (3.8 ACRES)
NOT TO SCALE

EXHIBIT B

“Landscape Plan for Fire Station #31 and Police / Fire Storage”

SAN VINCENTE STREET

NOTE:
PIPE ROUTING IS DIAGRAMMATIC AND SHOWN THROUGH PARKING AREA FOR CLARITY PURPOSES ONLY. UNLESS SLEEVING IS INDICATED, ROUTE PIPING THROUGH PLANTING AREAS ONLY.

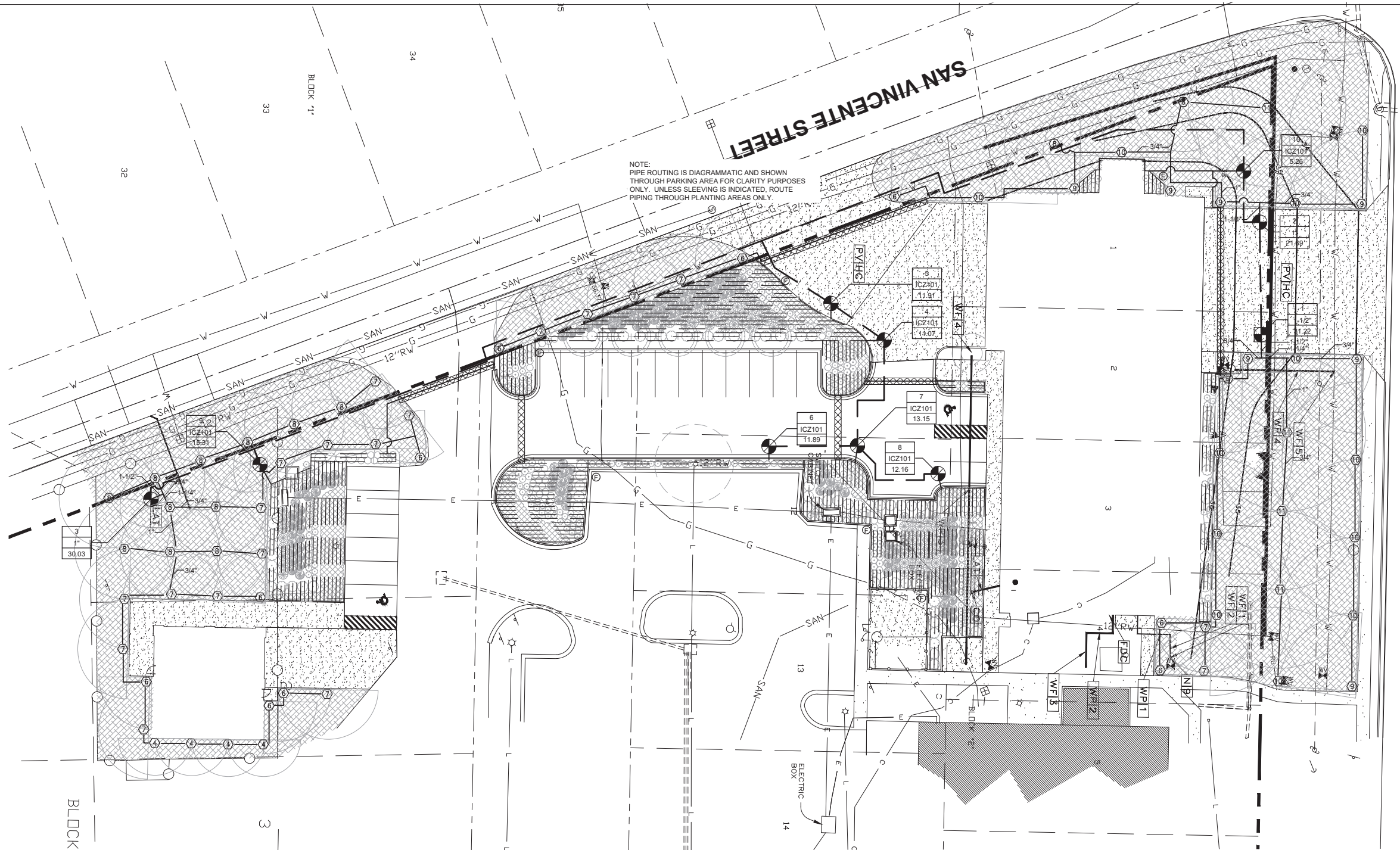

IRRIGATION LEGEND

	2" SCH. 40 MAINLINE, PURPLE PIPE		1 ZONE NUMBER
	CLASS 200 LATERALS, PURPLE PIPE - SIZE AS NOTED		1-1/2" VALVE SIZE
	SCH. 40 SLEEVE, SIZE AS NOTED		35 GALLONS PER MINUTE

- IRRIGATION NOTES:**
- LOCATE ALL UTILITIES BEFORE DIGGING. PROTECT ALL UTILITIES FROM DAMAGE DURING CONSTRUCTION.
 - IRRIGATION SYSTEM WILL USE RECLAIMED WATER. PROVIDE IRRIGATION COMPONENTS WITH NON-POTABLE MARKINGS, AND SIGNS, FOR RECLAIMED WATER. DO NOT DRINK. NOTE: ALL PIPING MUST BE PURPLE INDICATION REUSE WATER.
 - PIPE ROUTING IS DIAGRAMMATIC. PLACE IRRIGATION LINES WITHIN PLANTING AND TURF AREAS UNLESS SLEEVING IS INDICATED. ROUTE PIPING TO AVOID TREE LOCATIONS. LOCATE MAINLINE AND VALVE BOXES WITHIN PROPERTY LINES.
 - SYSTEM IS DESIGNED TO OPERATE AT 35 GPM AT 70 PSI.
 - PROCURE ALL NECESSARY PERMITS TO COMPLETE INSTALLATION OF IRRIGATION SYSTEM PER STATE AND LOCAL CODES.
 - PROVIDE SLEEVING AS INDICATED ON PLAN TO ACCOMMODATE LATERAL LINES, MAIN LINES, OR CONTROL WIRE.
 - PROVIDE A MINIMUM 12" COVER OVER LATERAL LINES AND A MINIMUM OF 18" COVER OVER MAINLINES.
 - INSTALL ALL ELECTRICAL SERVICE TO MEET LOCAL CODES.
 - PROVIDE POP-UP SPRINKLERS ONLY. MOUNT SPRINKLERS ON POLY PIPE WITH BARBED FASTENERS UNLESS OTHERWISE SPECIFIED IN PROVIDED DETAILS.
 - MOUNT HEADS FLUSH WITH FINISHED GRADE. INSTALL HEADS 6" OFF ALL SIDEWALKS AND 1" FROM BUILDING WALLS.
 - INSTALL VALVES IN 15" BOXES WITH TAMPER RESISTANT LIDS.
 - ALL IRRIGATION CONTROL WIRE TO BE 14-GAUGE WIRE. PROVIDE WHITE FOR COMMON, RED FOR HOT, AND A SPARE BLUE WIRE PARALLEL TO COMMON THROUGHOUT THE ENTIRE SYSTEM.
 - MAKE ALL WIRE SPLICES WITH WATERPROOF SPLICE KITS RATED FOR DIRECT BURIAL. NEATLY COIL 30" OF SLACK WIRE IN VALVE BOX.
 - ADJUST HEADS TO MAXIMIZE COVERAGE AND MINIMIZE OVERSPRAY.
 - SEE SHEET IP2 FOR INSTALLATION DETAILS.

IRRIGATION SCHEDULE

QUANTITY	KEY	MODEL (HUNTER UNLESS OTHERWISE NOTED)	GALLONS PER MINUTE
4	4	PROS-04-PRS40-CP-NP-MP1000-210 14' HALF	0.42 @ 40 PSI
10	6	PROS-04-PRS40-CP-NP-MP2000-90 20' QUARTER	0.43 @ 40 PSI
19	7	PROS-04-PRS40-CP-NP-MP2000-210 19' HALF	0.77 @ 40 PSI
13	8	PROS-04-PRS40-CP-NP-MP2000-360 19' FULL	1.48 @ 40 PSI
8	9	PROS-04-PRS40-CP-NP-MP3000-90 30' QUARTER	0.86 @ 40 PSI
12	10	PROS-04-PRS40-CP-NP-MP3000-210 30' HALF	1.82 @ 40 PSI
4	11	PROS-04-PRS40-CP-NP-MP3000-360 30' FULL	3.64 @ 40 PSI
2	1"	1" ELECTRIC REMOTE CONTROL VALVE PGV-NP-100G-S	
1	1-1/2"	1-1/2" ELECTRIC REMOTE CONTROL VALVE PGV-NP-150G-S	
7	ICZ101	1" DRIP VALVE KIT ICZ-NP-101	
1	A	HUNTER PRO C	
1	▲	WEATHER SENSOR	
6	⊙	FLUSH VALVE	
		RAINBIRD XFD-06-12 INLINE DRIP SPACE LINE 4" OFF CURB, 12" OFF BUILDING 18" O.C.	

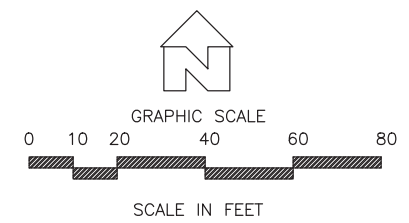

Alan D. Holt,
A.S.L.A.
LANDSCAPE ARCHITECT, PA
FL LC#26000193
P.O. BOX 2549
PANAMA CITY, FL 32402
TELEPHONE: (850)914-9006
E-MAIL:alan@alandholtasla.com
Job Number: 22026

REVISIONS

NO.	DESCRIPTION	DRAWN	CHECKED	DATE

PHASE	DRAWN	CHECKED	DATE
SCHEMATIC DESIGN			11/05/21
DESIGN DEVELOPMENT			12/17/21
60% DOCUMENTS			02/11/22
90% CONSTRUCTION DOCUMENTS			05/31/22
CONSTRUCTION DOCUMENTS			05/16/22

JRA ARCHITECTS 2211 THOMAS DR., STE 100
PANAMA CITY BEACH, FL
PHONE: (850) 236-9832
Commission Number: 21804

PROJECT:
PANAMA CITY BEACH
FIRE STATION # 31
REPLACEMENT
BAY COUNTY, FLORIDA

SHEET TITLE:
IRRIGATION PLAN

SHEET NUMBER:
IP1

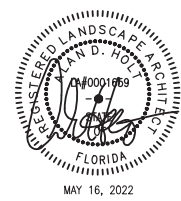

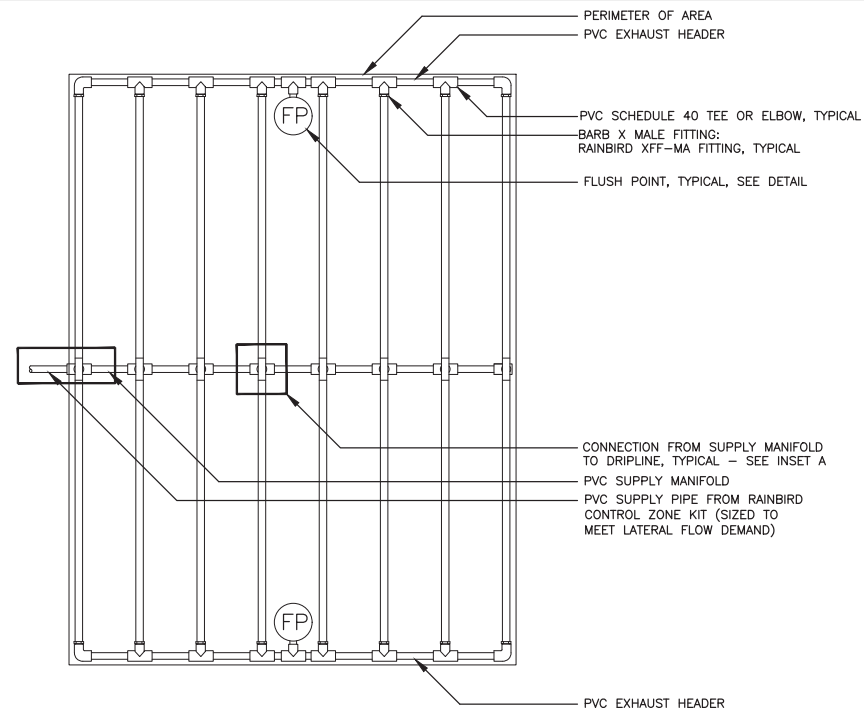

- NOTES:
- DISTANCE BETWEEN LATERAL ROWS AND EMITTER SPACING TO BE BASED ON SOIL TYPE, PLANT MATERIALS AND CHANGES IN ELEVATION. SEE INSTALLATION SPECIFICATIONS ON RAIN BIRD WEB SITE (WWW.RAINBIRD.COM) FOR SUGGESTED SPACING.
 - LENGTH OF LONGEST DRIPLINE LATERAL SHOULD NOT EXCEED THE MAXIMUM SPACING SHOWN IN THE ACCOMPANYING TABLE.
 - WHEN USING 17MM INSERT FITTINGS WITH DESIGN PRESSURE OVER 50PSI, IT IS RECOMMENDED THAT STAINLESS STEEL CLAMPS BE INSTALLED ON EACH FITTING.

7 XFD ON-SURFACE DRIPLINE CENTER FEED LAYOUT
IP2 SCALE: N.T.S.

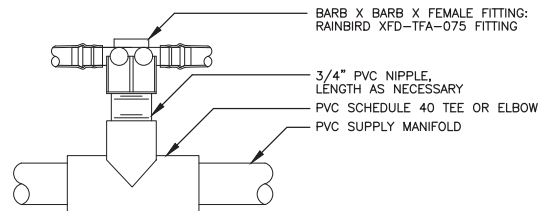

INSET A

Inlet Pressure psi	12" Spacing		18" Spacing		24" Spacing	
	Nominal Flow (gph)	Nominal Flow (gph)	Nominal Flow (gph)	Nominal Flow (gph)	Nominal Flow (gph)	Nominal Flow (gph)
15	0.6	0.9	0.6	0.9	0.6	0.9
20	273	155	314	250	424	322
30	318	169	353	294	508	368
40	360	230	413	350	586	414
50	395	255	465	402	652	474
60	417	285	528	420	720	488
60	460	290	596	455	780	514

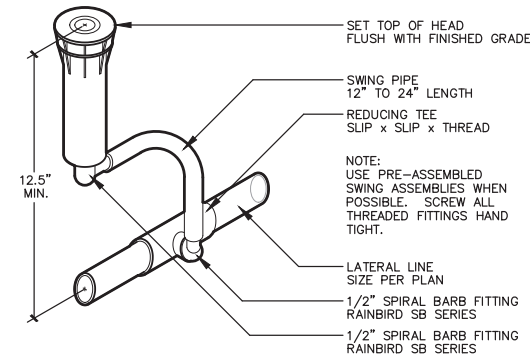

3 SPRAYHEAD DETAIL
IP2 SCALE: 1/4"=1"
© 2001 ALAN D. HOLT, A.S.L.A.

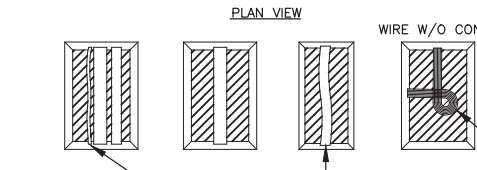
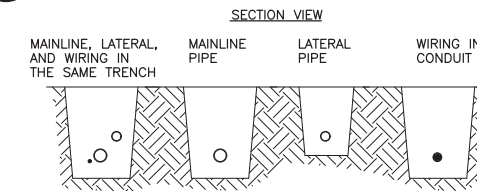

- RUN WIRING BENEATH AND BESIDE MAINLINE. TAPE AND BUNDLE AT 10-FOOT INTERVALS.
- ALL SOLVENT WELD PLASTIC PIPING TO BE SNAKED IN TRENCH AS SHOWN.
- TIE A 24-INCH LOOP IN ALL WIRING AT CHANGES OF DIRECTION OF 30° OR GREATER. UNTIE AFTER ALL CONNECTIONS HAVE BEEN MADE.

2 PIPE & WIRE TRENCHING
IP2 SCALE: N.T.S.

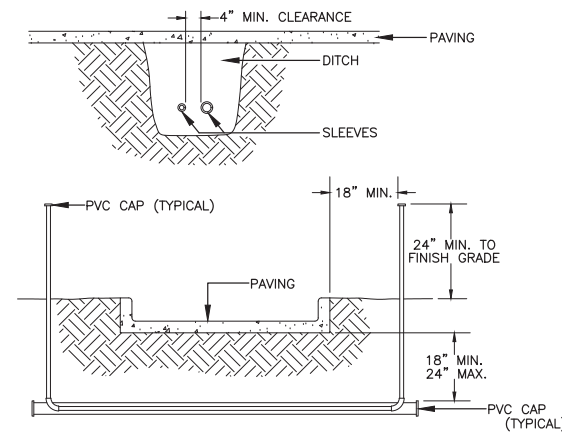

- NOTES:
- ALL PVC IRRIGATION SLEEVES TO BE SCHEDULE 40 PIPE.
 - ALL JOINTS TO BE SOLVENT WELDED AND WATERTIGHT.
 - WHERE THERE IS MORE THAN ONE SLEEVE, EXTEND THE SMALLER SLEEVE TO 24-INCHES MINIMUM ABOVE FINISH GRADE.
 - MECHANICALLY TAMP TO 95% PROCTOR.

1 SLEEVING DETAIL
IP2 SCALE: N.T.S.

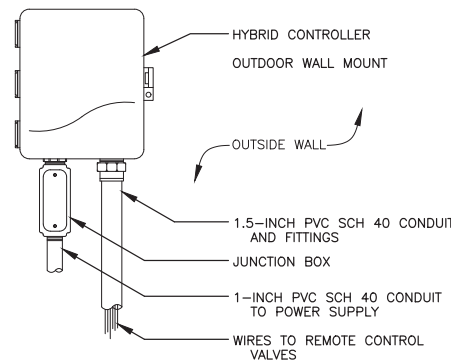

5 HYBRID CONTROLLER
IP2 SCALE: N.T.S.

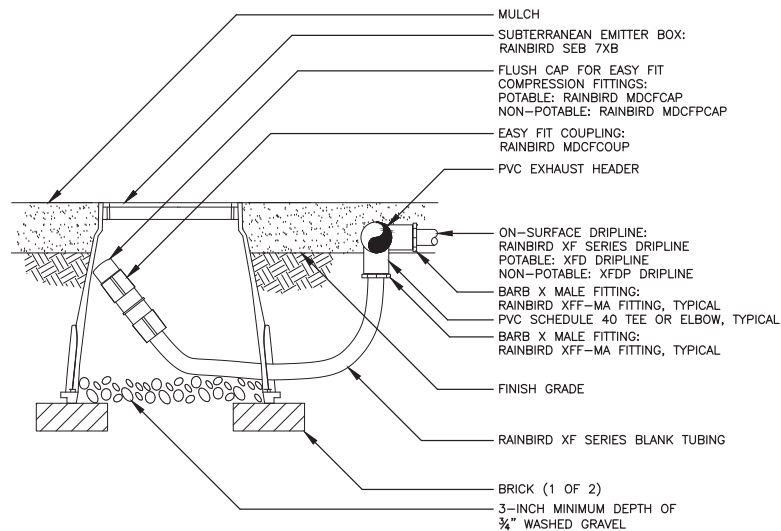

6 FLUSH POINT DETAIL
IP2 SCALE: N.T.S.

- NOTE:
- ALLOW A MINIMUM OF 6-INCHES OF DRIPLINE TUBING IN VALVE BOX IN ORDER TO DIRECT FLUSHED WATER OUTSIDE VALVE BOX.

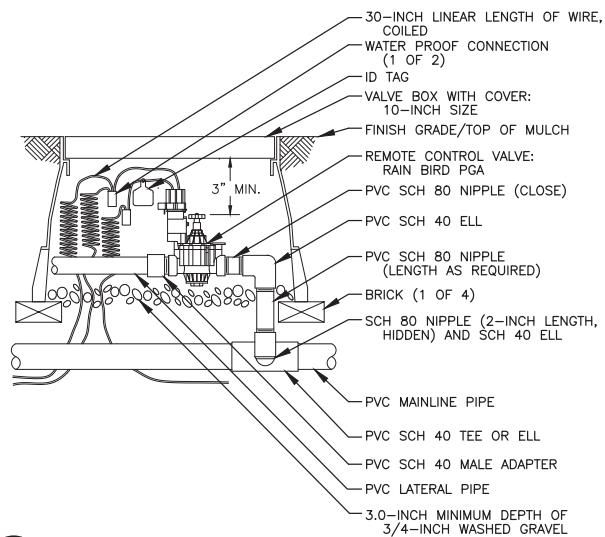

4 REMOTE CONTROL VALVE
IP2 SCALE: N.T.S.

Alan D. Holt,
A.S.L.A.

LANDSCAPE ARCHITECT, PA

FL LC#26000193
P.O. BOX 2549
PANAMA CITY, FL 32402
TELEPHONE: (850)914-9006
E-MAIL:alan@alandholtasla.com

Job Number: 22026

REVISIONS				
NO.	DESCRIPTION	DRAWN	CHECKED	DATE
PHASE				
		DRAWN	CHECKED	DATE
SCHEMATIC DESIGN				11/05/21
DESIGN DEVELOPMENT				12/17/21
60% DOCUMENTS				02/11/22
90% CONSTRUCTION DOCUMENTS				05/31/22
CONSTRUCTION DOCUMENTS				05/16/22

JRA ARCHITECTS 2211 THOMAS DR., STE 100
PANAMA CITY BEACH, FL
PHONE: (850) 236-9832
Commission Number: 21804

PROJECT:
PANAMA CITY BEACH
FIRE STATION # 31
REPLACEMENT
BAY COUNTY, FLORIDA

SHEET TITLE:
IRRIGATION DETAILS

SHEET NUMBER:
IP2



EXHIBIT C

“Landscape Plan for Fire Station #32”

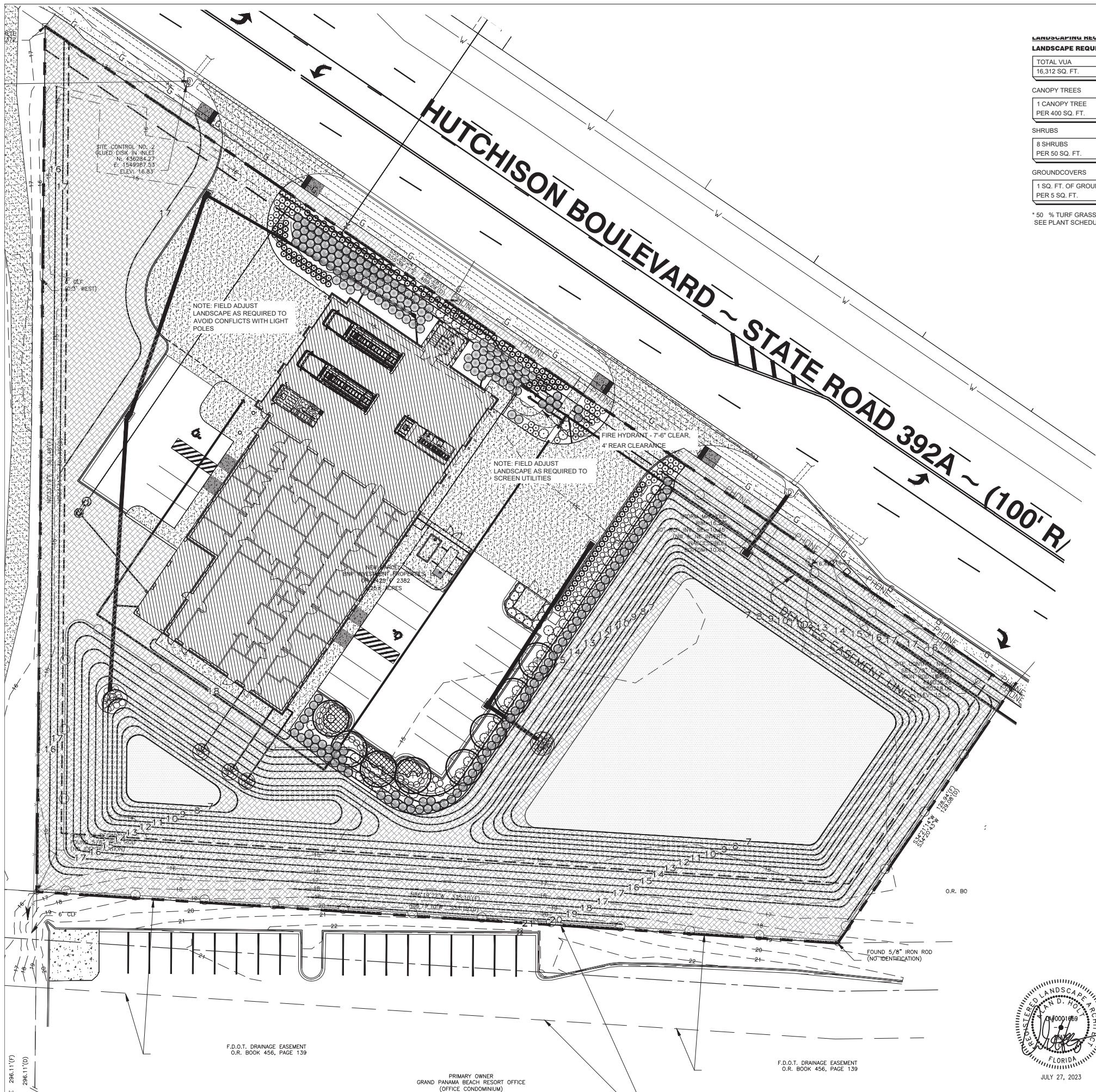

LANDSCAPING REQUIREMENTS
LANDSCAPE REQUIRED/PROVIDED - PER TYPICAL VUA STANDARDS

TOTAL VUA	PERCENTAGE REQUIREMENT	REQUIRED LANDSCAPE AREA
16,312 SQ. FT.	20%	3,262 SQ. FT.

CANOPY TREES		
1 CANOPY TREE PER 400 SQ. FT.	REQUIRED	PROVIDED
	8	8

SHRUBS		
8 SHRUBS PER 50 SQ. FT.	REQUIRED	PROVIDED
	522	522

GROUNDCOVERS		
1 SQ. FT. OF GROUNDCOVER PER 5 SQ. FT.	REQUIRED	PROVIDED
	712	712

* 50 % TURF GRASS SUBSTITUTION CLAIMED.
 SEE PLANT SCHEDULE FOR TOTAL SOD QUANTITY.

LANDSCAPE LEGEND

GROUNDCOVER	
[Symbol]	49,000± S.F. INCLUDING 10% FOR WASTE 'EMERALD' ZOYSIA ZOYSIA JAPONICA 'EMERALD'
[Symbol]	12,000± S.F. INCLUDING 10% FOR WASTE SEEDED AREA
[Symbol]	28 VARIEGATED FLAX LILY DIANELLA TASMANICA 'VARIEGATA' 1 GAL. 3" O.C.
[Symbol]	63 'CORAL DRIFT' ROSE ROSA 'MEIDRIFORA' 3 GAL. 30" O.C.
[Symbol]	130 'PARSONS' JUNIPER JUNIPERUS CHINENSIS 'PARSONII' 1 GAL. 30" O.C.
[Symbol]	136 PURPLE MUHLY GRASS MUHLENBERGIA CAPILLARIS 1 GAL. 42" O.C.
[Symbol]	70 FAKAHATCHEE GRASS TRIPSACUM DACTYLOIDES 1 GAL. 42" O.C.
[Symbol]	55 DWARF YAUPON HOLLY ILEX VOMITORIA 'NANA' 3 GAL. 30" O.C.
[Symbol]	68 PINEAPPLE GUAVA ACCA SELLOWIANA 3 GAL. 4" O.C.
[Symbol]	5 'MUSKOGEE' CRAPE MYRTLE LAGERSTROEMIA INDICA 'MUSKOGEE' 30 GAL. MIN. 3 STEMS @ 1' CAL.

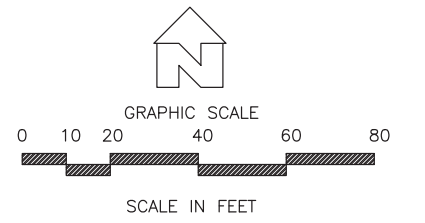

- LANDSCAPE NOTES:**
- ALL PLANT MATERIAL FLORIDA #1 OR BETTER.
 - FERTILIZE ALL PLANTINGS WITH OSMOCOTE OR OTHER APPROVED SLOW RELEASE FERTILIZER AT MANUFACTURER'S RECOMMENDED RATE BEFORE MULCHING.
 - DECREASE PLANT SPACING AS REQUIRED TO ALLOW PLACEMENT OF THE DESIGNATED NUMBER OF PLANTS PER GROUPING.
 - APPLY GASARON OR OTHER APPROVED PRE-EMERGENT HERBICIDE TO ALL PLANTING AREAS BEFORE MULCHING.
 - MULCH ALL AREAS OF TREE, SHRUB AND GROUNDCOVER MASS PLANTINGS WITH 3" PINESTRAW MULCH.
 - SOD ALL DISTURBED AREAS.
 - AUTOMATIC IRRIGATION SYSTEM TO PROVIDE 100% COVERAGE OF ALL LANDSCAPE AREAS.
 - PROVIDE BACKFLOW PREVENTION PER CITY REQUIREMENTS.
 - PROVIDE RAIN SHUT OFF DEVICE PER FL. STATE LAW.



Alan D. Holt,
A.S.L.A.
LANDSCAPE ARCHITECT, PA
 FL LC#26000193
 P.O. BOX 2549
 PANAMA CITY, FL 32402
 TELEPHONE: (850)914-9006
 E-MAIL: alan@alandholtasla.com
 Job Number: 23064

REVISIONS

NO.	DESCRIPTION	DRAWN	CHECKED	DATE

PHASE	DRAWN	CHECKED	DATE
95% DOCUMENTS			05/10/23
BID DOCUMENTS			08/01/23

JRA ARCHITECTS 2211 THOMAS DR., STE 100
 PANAMA CITY BEACH, FL
 PHONE: (850) 236-9832
 Commission Number: 21804

McNEIL-CARROLL ENGINEERING, INC. 17600 Panama City Beach Parkway
 Panama City Beach, Florida 32413
 Phone: 850-294-1790
 Fax: 850-294-1791
 Professional Engineering Consultants
 STATE OF FLORIDA CERTIFICATE OF AUTHORIZATION NUMBER 7288

PROJECT:
 PANAMA CITY BEACH
 FIRE STATION #32
 HUTCHISON BLVD

BAY COUNTY, FLORIDA

SHEET TITLE:
 LANDSCAPE PLAN

SHEET NUMBER:
 LP1

F.D.O.T. DRAINAGE EASEMENT
 O.R. BOOK 456, PAGE 139

PRIMARY OWNER
 GRAND PANAMA BEACH RESORT OFFICE
 (OFFICE CONDOMINIUM)

F.D.O.T. DRAINAGE EASEMENT
 O.R. BOOK 456, PAGE 139

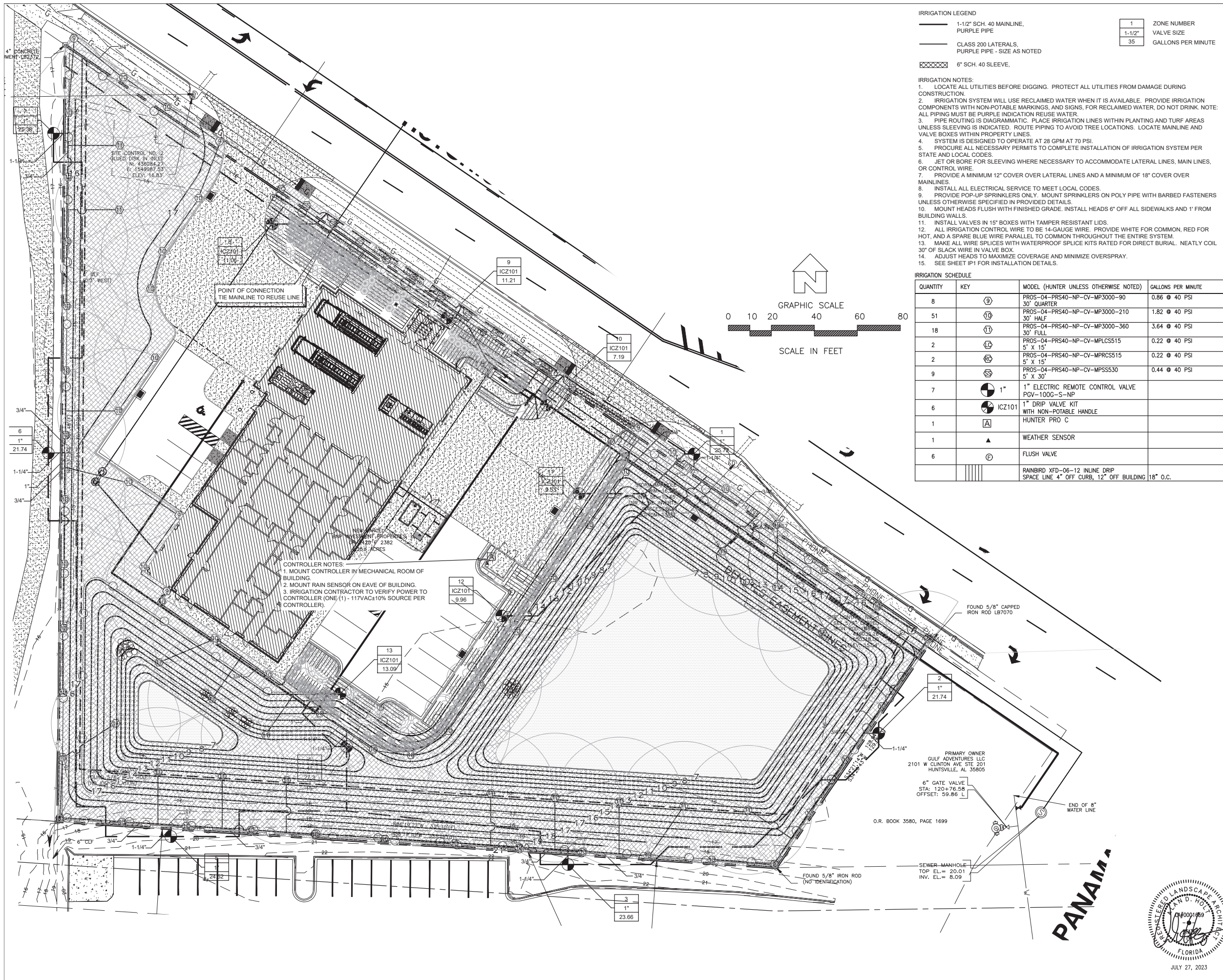

IRRIGATION LEGEND

— 1-1/2" SCH. 40 MAINLINE, PURPLE PIPE	1	ZONE NUMBER
— CLASS 200 LATERALS, PURPLE PIPE - SIZE AS NOTED	1-1/2"	VALVE SIZE
XXXXX 6" SCH. 40 SLEEVE	35	GALLONS PER MINUTE

- IRRIGATION NOTES:**
- LOCATE ALL UTILITIES BEFORE DIGGING. PROTECT ALL UTILITIES FROM DAMAGE DURING CONSTRUCTION.
 - IRRIGATION SYSTEM WILL USE RECLAIMED WATER WHEN IT IS AVAILABLE. PROVIDE IRRIGATION COMPONENTS WITH NON-POTABLE MARKINGS, AND SIGNS, FOR RECLAIMED WATER. DO NOT DRINK. NOTE: ALL PIPING MUST BE PURPLE INDICATION REUSE WATER.
 - PIPE ROUTING IS DIAGRAMMATIC. PLACE IRRIGATION LINES WITHIN PLANTING AND TURF AREAS UNLESS SLEEVING IS INDICATED. ROUTE PIPING TO AVOID TREE LOCATIONS. LOCATE MAINLINE AND VALVE BOXES WITHIN PROPERTY LINES.
 - SYSTEM IS DESIGNED TO OPERATE AT 28 GPM AT 70 PSI.
 - PROCURE ALL NECESSARY PERMITS TO COMPLETE INSTALLATION OF IRRIGATION SYSTEM PER STATE AND LOCAL CODES.
 - JET OR BORE FOR SLEEVING WHERE NECESSARY TO ACCOMMODATE LATERAL LINES, MAIN LINES, OR CONTROL WIRE.
 - PROVIDE A MINIMUM 12" COVER OVER LATERAL LINES AND A MINIMUM OF 18" COVER OVER MAINLINES.
 - INSTALL ALL ELECTRICAL SERVICE TO MEET LOCAL CODES.
 - PROVIDE POP-UP SPRINKLERS ONLY. MOUNT SPRINKLERS ON POLY PIPE WITH BARBED FASTENERS UNLESS OTHERWISE SPECIFIED IN PROVIDED DETAILS.
 - MOUNT HEADS FLUSH WITH FINISHED GRADE. INSTALL HEADS 6" OFF ALL SIDEWALKS AND 1" FROM BUILDING WALLS.
 - INSTALL VALVES IN 15" BOXES WITH TAMPER RESISTANT LIDS.
 - ALL IRRIGATION CONTROL WIRE TO BE 14-GAUGE WIRE. PROVIDE WHITE FOR COMMON, RED FOR HOT, AND A SPARE BLUE WIRE PARALLEL TO COMMON THROUGHOUT THE ENTIRE SYSTEM.
 - MAKE ALL WIRE SPLICES WITH WATERPROOF SPLICE KITS RATED FOR DIRECT BURIAL. NEATLY COIL 30' OF SLACK WIRE IN VALVE BOX.
 - ADJUST HEADS TO MAXIMIZE COVERAGE AND MINIMIZE OVERSPRAY.
 - SEE SHEET IP1 FOR INSTALLATION DETAILS.

IRRIGATION SCHEDULE

QUANTITY	KEY	MODEL (HUNTER UNLESS OTHERWISE NOTED)	GALLONS PER MINUTE
8	9	PROS-04-PRS40-NP-CV-MP3000-90 30' QUARTER	0.86 @ 40 PSI
51	10	PROS-04-PRS40-NP-CV-MP3000-210 30' HALF	1.82 @ 40 PSI
18	11	PROS-04-PRS40-NP-CV-MP3000-360 30' FULL	3.64 @ 40 PSI
2	12	PROS-04-PRS40-NP-CV-MPLCS515 5' X 15'	0.22 @ 40 PSI
2	13	PROS-04-PRS40-NP-CV-MPRCS515 5' X 15'	0.22 @ 40 PSI
9	14	PROS-04-PRS40-NP-CV-MPSS530 5' X 30'	0.44 @ 40 PSI
7	15	1" ELECTRIC REMOTE CONTROL VALVE PGV-100G-S-NP	
6	16	1" DRIP VALVE KIT WITH NON-POTABLE HANDLE HUNTER PRO C	
1	17	WEATHER SENSOR	
6	18	FLUSH VALVE	
		RAINBIRD XFD-06-12 INLINE DRIP SPACE LINE 4" OFF CURB, 12" OFF BUILDING 18" O.C.	

- CONTROLLER NOTES:**
- MOUNT CONTROLLER IN MECHANICAL ROOM OF BUILDING.
 - MOUNT RAIN SENSOR ON EAVE OF BUILDING.
 - IRRIGATION CONTRACTOR TO VERIFY POWER TO CONTROLLER (ONE (1) - 117VAC/10% SOURCE PER CONTROLLER).

**Alan D. Holt,
A.S.L.A.**

LANDSCAPE ARCHITECT, PA

FL LC#26000193
P.O. BOX 2549
PANAMA CITY, FL 32402
TELEPHONE: (850)914-9006
E-MAIL: alan@alandholtsla.com

Job Number: 23064

REVISIONS

NO.	DESCRIPTION	DRAWN	CHECKED	DATE

PHASE	DRAWN	CHECKED	DATE
95% DOCUMENTS			05/10/23
BID DOCUMENTS			08/01/23

JRA ARCHITECTS 2211 THOMAS DR., STE 100
PANAMA CITY BEACH, FL
PHONE: (850) 236-9832
Commission Number: 21804

McNEIL-CARROLL ENGINEERING, INC. 17600 Panama City Beach Parkway
Panama City Beach, Florida 32410
Phone: 850-294-1790
Fax: 850-294-1791
Professional Engineering Consultants
STATE OF FLORIDA CERTIFICATE OF AUTHORIZATION NUMBER 7288

PROJECT:
PANAMA CITY BEACH
FIRE STATION #32
HUTCHISON BLVD

BAY COUNTY, FLORIDA

SHEET TITLE:
IRRIGATION PLAN

SHEET NUMBER:
IP1

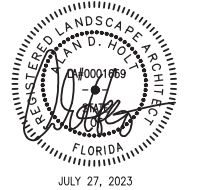

PANAMA CITY BEACH

PRIMARY OWNER
GULF ADVENTURES LLC
2101 W CLINTON AVE, STE 201
HUNTSVILLE, AL 35895

6" GATE VALVE
STA: 120+76.58
OFFSET: 59.86 L

O.R. BOOK 3580, PAGE 1699

SEWER MANHOLE
TOP EL. = 20.01
INV. EL. = 8.09

FOUND 5/8" IRON ROD
(NO IDENTIFICATION)

FOUND 5/8" CAPPED
IRON ROD LB7070

END OF 8"
WATER LINE

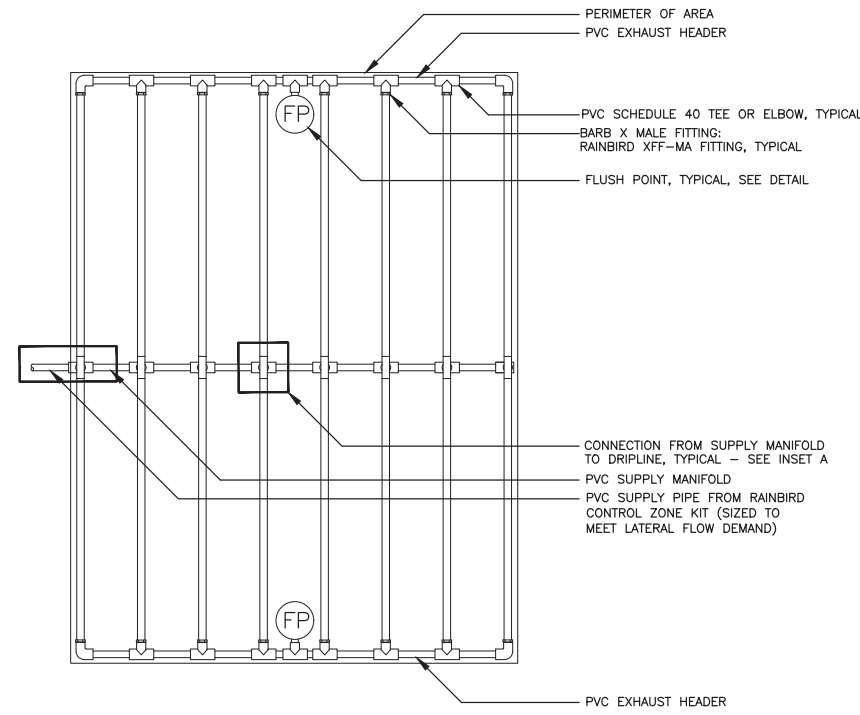

- NOTES:
- DISTANCE BETWEEN LATERAL ROWS AND EMITTER SPACING TO BE BASED ON SOIL TYPE, PLANT MATERIALS AND CHANGES IN ELEVATION. SEE INSTALLATION SPECIFICATIONS ON RAIN BIRD WEB SITE (WWW.RAINBIRD.COM) FOR SUGGESTED SPACINGS.
 - LENGTH OF LONGEST DRIPLINE LATERAL SHOULD NOT EXCEED THE MAXIMUM SPACING SHOWN IN THE ACCOMPANYING TABLE.
 - WHEN USING 17MM INSERT FITTINGS WITH DESIGN PRESSURE OVER 50PSI, IT IS RECOMMENDED THAT STAINLESS STEEL CLAMPS BE INSTALLED ON EACH FITTING.

7 XFD ON-SURFACE DRIPLINE CENTER FEED LAYOUT
SCALE: N.T.S.

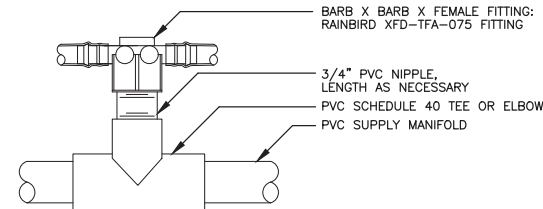

XFD Dripline Maximum Lateral Lengths (Feet)

Inlet Pressure psi	12" Spacing		18" Spacing		24" Spacing	
	Nominal Flow (gph)	Nominal Flow (gph)	Nominal Flow (gph)	Nominal Flow (gph)	Nominal Flow (gph)	Nominal Flow (gph)
15	273	155	314	250	424	322
20	318	169	353	294	508	368
30	360	230	413	350	586	414
40	395	255	465	402	652	474
50	417	285	528	420	720	488
60	460	290	596	455	780	514

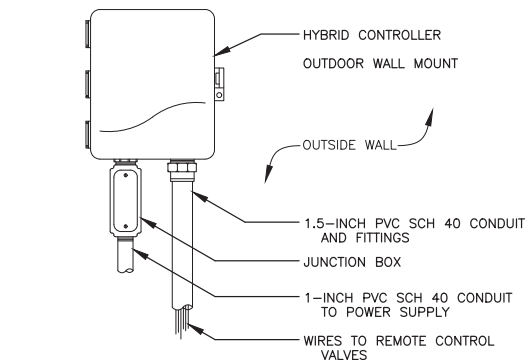

5 HYBRID CONTROLLER
SCALE: N.T.S.

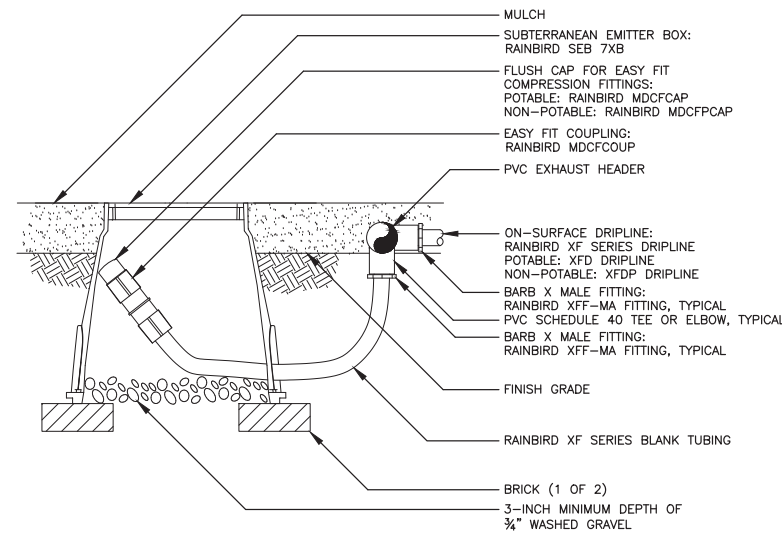

6 FLUSH POINT DETAIL
SCALE: N.T.S.

- NOTE:
- ALLOW A MINIMUM OF 6-INCHES OF DRIPLINE TUBING IN VALVE BOX IN ORDER TO DIRECT FLUSHED WATER OUTSIDE VALVE BOX.

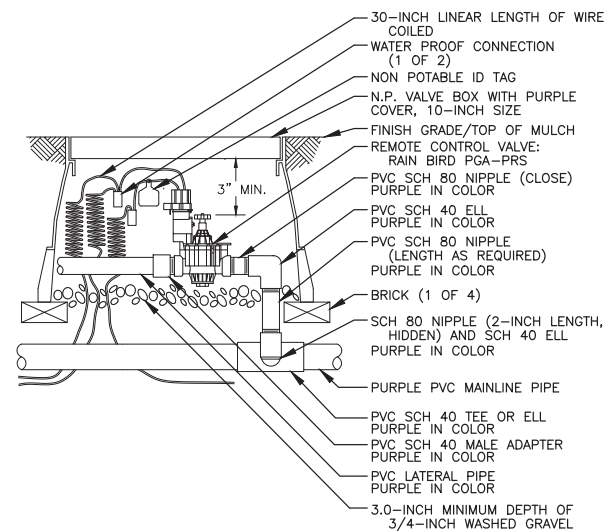

4 REMOTE CONTROL VALVE -NON POTABLE
SCALE: N.T.S.

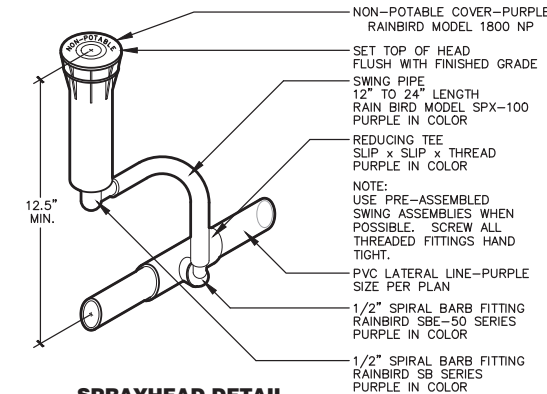

3 W/ NON-POTABLE COVER-PURPLE
SCALE: 1/4"=1"

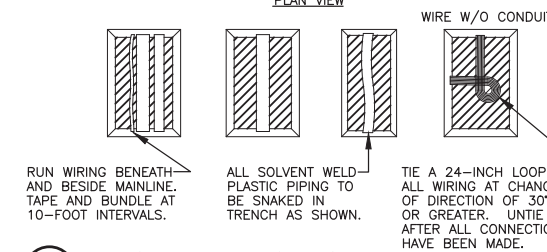
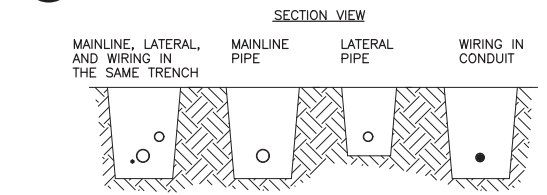

2 PIPE & WIRE TRENCHING
SCALE: N.T.S.

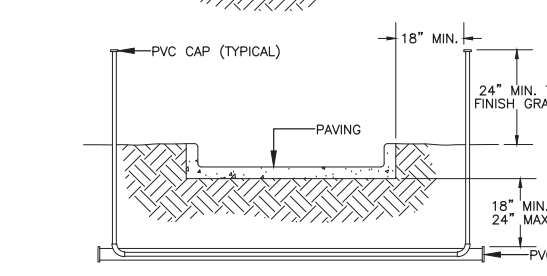
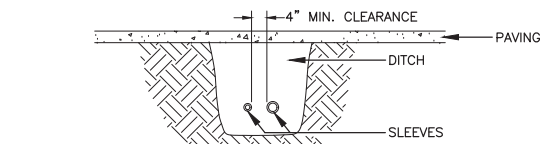

- NOTES:
- ALL PVC IRRIGATION SLEEVES TO BE SCHEDULE 40 PURPLE PIPE.
 - ALL JOINTS TO BE SOLVENT WELDED AND WATERTIGHT.
 - WHERE THERE IS MORE THAN ONE SLEEVE, EXTEND THE SMALLER SLEEVE TO 24-INCHES MINIMUM ABOVE FINISH GRADE.
 - MECHANICALLY TAMP TO 95% PROCTOR.

1 NON-POTABLE SLEEVING DETAIL
SCALE: N.T.S.

**Alan D. Holt,
A.S.L.A.**

**LANDSCAPE
ARCHITECT, PA**

FL LC#26000193
P.O. BOX 2549
PANAMA CITY, FL 32402
TELEPHONE: (850)914-9006
E-MAIL:alan@alandholtsla.com

Job Number: 23064

REVISIONS

NO.	DESCRIPTION	DRAWN	CHECKED	DATE

PHASE	DRAWN	CHECKED	DATE
95% DOCUMENTS			05/10/23
BID DOCUMENTS			08/01/23

JRA ARCHITECTS 2211 THOMAS DR., STE 100
PANAMA CITY BEACH, FL
PHONE: (850) 236-9832
Commission Number: 21804

McNEIL-CARROLL ENGINEERING, INC. Professional Engineering Consultants
17800 Panama City Beach Parkway
Panama City Beach, Florida 32413
Phone: 850-294-1790
Fax: 850-294-1791
STATE OF FLORIDA CERTIFICATE OF AUTHORIZATION NUMBER 7288

PROJECT:
PANAMA CITY BEACH
FIRE STATION #32
HUTCHISON BLVD

BAY COUNTY, FLORIDA

SHEET TITLE:
**IRRIGATION
DETAILS**

SHEET NUMBER:
IP2

JULY 27, 2023

