



City of  
**Panama City Beach**

**PCB City Hall**  
17007 PCB Parkway  
PCB, FL 32413  
P: (850) 233-5100  
F: (850) 233-5108  
www.pcbfl.gov

**MINUTES** of the **June 27, 2024** Regular Meeting of the City Council of the City of Panama City Beach, Florida, and when permitted or required by the subject matter, the Panama City Beach Community Redevelopment Agency.

**Mayor Stuart Tettemer called the June 27, 2024 meeting to order at 9:00 a.m.**

**ROLL CALL**

**COUNCILMAN PAUL CASTO**  
**COUNCILMEMBER MARY COBURN**  
**COUNCILMAN ETHAN REGISTER**  
**VICE MAYOR MICHAEL JARMAN**  
**MAYOR STUART TETTEMER**

**A quorum was present with all five members of City Council.** Others present were City Manager Drew Whitman, Assistant City Manager Holly White, City Attorney Cole Davis, City Clerk Lynne Fasone, Directors, staff, and members of the public and press.

**INVOCATION AND PLEDGE OF ALLEGIANCE**

Pastor Ramon Duvall from the Beachside Fellowship Church led the invocation. Councilman Paul Casto led the Pledge of Allegiance.

**COMMUNITY ANNOUNCEMENTS**

Mayor Tettemer presented community announcements.

**APPROVAL OF MEETING MINUTES**

Mayor Tettemer called for approval of the June 13, 2024 regular meeting minutes. **Vice Mayor Jarman so moved. Councilmember Coburn seconded the motion. The June 13 meeting minutes were unanimously approved by a (5-0) roll call vote.**

Councilman Casto	Aye
Councilmember Coburn	Aye
Councilman Register	Aye
Vice Mayor Jarman	Aye
Mayor Tettemer	Aye

**APPROVAL OF AGENDA**

Mayor Tettemer called for approval, additions and/or deletions to the agenda. Manager Whitman recommended adding a discussion item regarding water safety to the agenda. Mayor Tettemer called for additional changes. Hearing and seeing none, Mayor Tettemer recommended adding it first to the agenda. **Vice Mayor Jarman moved to approve the agenda, as amended. Councilman Casto seconded the motion. All were unanimously in favor of approval of the agenda as amended by a (5-0) roll call vote.**

Councilman Casto	Aye
Councilmember Coburn	Aye
Councilman Register	Aye
Vice Mayor Jarman	Aye
Mayor Tettemer	Aye

## **PRESENTATIONS**

Councilman Casto presented Ms. Kathy Younce, Assistant Public Works Director, with a 20 years of service award. Councilman Casto thanked Ms. Younce for her dedication and years of service.

Mayor Tetteer invited Mr. Andrew Starr, Vice President, Chief Health Operations Officer at Tallahassee Memorial HealthCare, Inc. to the podium to present an update on the Hospital. Mayor Tetteer thanked Mr. Starr.

Mayor Tetteer invited Mr. Wyatt Rothwell, City Engineer, to the podium to present the 2024 Street Resurfacing Project update.

City Council had a brief discussion regarding the needed improvements to Clarence Street and the timeline of completion, taking approximately eight months from the end of the year. Mayor Tetteer thanked Mr. Rothwell.

## **PUBLIC COMMENTS - NON-AGENDA BUSINESS (LIMITED TO THREE MINUTES)**

Mayor Tetteer provided instructions and then opened the floor to non-agenda business public comments, limited to three minutes each, at 9:40 a.m.

1. Burnie Thompson – Mr. Thompson commented on the Chief of Police investigation. Mr. Thompson inquired as to which policies allowed the City to remove the Chief. Mr. Thompson inquired if the Chief would ever get the name of his accuser and did the policy apply to everyone or just the Chief. Mr. Thompson inquired as to how many other people, employees, had been investigated and requested the names please. Mr. Thompson commented that, in his opinion, it was not a complaint, just a piece of paper. Mr. Thompson commented on a man who was stopped by a K9 Officer for more than an hour and noted in his opinion the stop was a violation of his rights. Mr. Thompson asked the City to look into the stop/complaint.
2. Nancy Viejo – Ms. Viejo commented that Mr. Bill Caravello should be appointed to the Airport Board. Ms. Viejo commented on the Beach Flag System and noted in her opinion the old beach flag system was easier to understand and that the City needed more police and lifeguards on the beach.
3. Scott Heilman – Mr. Heilman commented that the actions taken against Chief Talamantez were disgusting and the Mayor's reckless endorsement of these actions were a disgrace and embarrassment. Mr. Heilman commented that the Chief and the women were owed apologies. Mr. Heilman commented on the Mayor using his name, without permission, in an ad during his campaign.

Vice Mayor Jarman recommended that Council address the investigation now. Vice Mayor Jarman explained that none of Council had anything to do with the investigation, it was an administrative matter. Mayor Tetteer concurred and explained that he received an anonymous letter and then handed it over to the City Manager to investigate. Mayor Tetteer added that the City and City Council fully stand by the Chief. Vice Mayor Jarman inquired if the City Manager wanted to address the SOP (Standing Operating Procedure). Manager Whitman reported that he would be updating SOPs, and further discussed the Governor's new Bill. Manager Whitman discussed the timeline of the investigation, that the investigation was run by the book, and that at the time he was acting according to the policies that the Police Department had in place. Mayor Tetteer thanked Mr. Whitman for the clarification.

4. Alfie Martin, Mr. Martin thanked Staff and the Chief for their work and noted that the Chief was cleared, and he appreciated the Chief. Mr. Martin thanked everyone for doing a good job with the investigation.
5. Captain Gary Wayne Beck, 2601 Beech Street –Mr. Beck played a recording reciting the First, Second, Third and Fourth Amendments. Mr. Beck further commented on the draft chicken ordinance.

6. Cliff Gornto, 206 West Lakeshore Drive - Mr. Gornto expressed a heartfelt thank you to the City for assisting him to connect his resident to the city's main sewer line. Mr. Gornto added that Mr. Mark Shaeffer listened to him and promised immediate action. Mr. Gornto commented that he was waiting on final approval from the FL Dept. of Protection. Mr. Gornto thanked Director Shaeffer, Staff and Council.
7. Lori Deaton – Ms. Deaton commented that she spoke in front of City Council at the end of February. Ms. Deaton asked Council to budget for a spay and neuter program in 2024.
8. Tom Campbell, 150 Crane Street – Mr. Campbell commented on the Airport Board application process. Mr. Campbell further commented on the Alf Coleman Road improvement project, the cost to tax holders and commented that in his opinion he thought it was a waste of money.
9. Mark Messarello – Mr. Messarello commented on the recent drownings. Mr. Messarello further commented on his ideas and suggestions on how to warn people about unsafe water. Mr. Messarello read comments from Next Door. Mr. Messarello further commented on paying for additional lifeguards and inquired if the City had approached St. Joe for help. Mr. Messarello commented, in his opinion, the City should hire seasonal spotters and form a task force to study problem.
10. Genice Hatcher, 108 Vestavia – Ms. Hatcher commented on abandoned boats, vehicles, high grass and miscellaneous building supplies that she sees around the Beach. Ms. Hatcher noted that she reported those items to Code Enforcement. Ms. Hatcher commented, in her opinion, residents needed to take pride in its City. Ms. Hatcher encouraged Council to hold everyone to higher standards and ask citizens and Code Enforcement Officials to do the same.
11. Chrissy (inaudible), - Ms. Chrissy spoke in favor of the 2024 Street Improvement Project. Ms. Chrissy recommended finishing projects before starting new projects, commented on traffic, Griffith Parkway, and the Airport Authority Board appointment.

Mayor Tetteimer called for further public comments. Hearing and seeing none, Mayor Tetteimer closed the public comment period at 10:10 a.m. Mayor Tetteimer asked Manager Whitman to respond to the public comments.

Manager Whitman reported, with respect to the investigation, he was the only person who initiated the investigation, the Mayor was the only person who knew about the letter, as he could not inform the other Councilmembers as it would have been a felony to do so. Manager Whitman added he considered Chief Talamantez a friend. Manager Whitman noted that the City would honor Mr. Thompson's public records request. Manager Whitman invited Ms. Viejo to attend the July 11 meeting for a presentation on the beach flag system. Manager Whitman noted he had already addressed Mr. Heilman's comments, and he agreed with Alfie's comments. Manager Whitman thanked Cliff for his comments, and added he would work with the State to see if that process could be moved forward. Manager Whitman concurred that he did meet with Ms. Lori Deaton about a possible spay and neuter program and invited her to come back during the budget workshop. Manager Whitman reported the appointment to the Airport Board would be addressed toward the end of today's agenda. Manager Whitman reported with respect to the Alf Coleman project, the City went forward with the project since it had money coming in from the State to improve the safety of that road.

Vice Mayor Jarman asked Mr. Scott Passmore to confirm that the City went ahead with the project because it had received State funding. Mr. Passmore concurred and discussed the design process, managing the flooding, acquiring land that needs to be budgeted, Hurricane Michael funding to raise the road, an FDOT grant for sidewalks and taking advantage of outside funding.

Manager Whitman reported with respect to Ms. Hatcher's comments, he did go out to Ms. Hatcher's residence and investigate her complaints. Manager Whitman further reported that Code Enforcement was

doing a great job. Lastly, Manager Whitman reported with respect to Ms. Chrissy those were statements, and the Airport Board would be addressed on the dais.

Mayor Tetteimer asked Council if they would like to address any of the public comments.

Vice Mayor Jarman reported, with respect to the resurfacing projects, resurfacing and DOT projects were two totally difference projects. Vice Mayor Jarman further discussed construction fatigue.

Councilman Casto reported that he agreed with Ms. Lori about a spay and neuter program being needed on the Beach, and he would like to look into it at budget time. Mayor Tetteimer concurred.

Mayor Tetteimer thanked everyone for the robust discussion.

**CONSENT AGENDA**

Mayor Tetteimer asked Clerk Fasone to read the Consent Agenda.

**RESOLUTION NO. 24-145, A RESOLUTION OF THE CITY OF PANAMA CITY BEACH, FLORIDA, APPROVING THE PURCHASE OF TWO TRAILER-MOUNTED BYPASS PUMPS FOR THE UTILITIES DEPARTMENT FROM THOMPSON PUMP & MANUFACTURING CO., INC. IN THE TOTAL AMOUNT OF \$183,173.00; AND AGREEING TO BE BOUND BY THE TERMS AND CONDITIONS OF THE FLORIDA SHERIFFS ASSOCIATION CONTRACT GOVERNING THAT PURCHASE.**

**RESOLUTION NO. 24-146, A RESOLUTION OF THE CITY OF PANAMA CITY BEACH, FLORIDA, APPROVING STATEWIDE MUTUAL AID AGREEMENT – 2023 WITH THE FLORIDA DIVISION OF EMERGENCY MANAGEMENT.**

**RESOLUTION NO. 24-147, A RESOLUTION OF THE CITY OF PANAMA CITY BEACH, FLORIDA, APPROVING A LIGHTING AGREEMENT WITH FLORIDA POWER & LIGHT COMPANY FOR INSTALLATION AND MAINTENANCE OF LIGHTING FACILITIES ON SR 30A (BACK BEACH ROAD) FROM THE PANAMA CITY BEACH CITY LIMITS EAST TO HEATHER DRIVE.**

**\*RESOLUTION NO. 24-148, A RESOLUTION OF THE CITY OF PANAMA CITY BEACH, FLORIDA, APPROVING TASK ORDERS WITH CHANDLER AND ASSOCIATES OF PANAMA CITY, INC. AND DEAL CONSULTING, P.A. FOR THE UPDATE OF APPRAISALS OF PROPERTIES NECESSARY FOR FRONT BEACH ROAD PROJECTS, AND FOR CONSULTATION, PREPARATION AND ATTENDANCE AT HEARINGS RELATED TO THE CITY’S ACQUISITION OF PROPERTIES BY EMINENT DOMAIN FOR TOTAL COMPENSATION NOT TO EXCEED \$50,000.00 EACH.**

Mayor Tetteimer noted the Consent Agenda was available to Council. **Vice Mayor Jarman moved to approve the Consent Agenda. Councilman Casto seconded the motion. All were unanimously in favor of approval of the Consent Agenda by a (5-0) roll call vote.**

Councilman Casto	Aye
Councilmember Coburn	Aye
Councilman Register	Aye
Vice Mayor Jarman	Aye
Mayor Tetteimer	Aye

**ADDED TO THE AGENDA. – BEACH SAFETY**

Mayor Tette mer invited staff to the podium. Chief Ray Morgan noted he was available to answer any questions.

Mayor Tette mer asked the Chief to discuss what had happened over the last week, including flags flying during the incidents.

Chief Morgan thanked his team and reported it was a tough week for everyone. Chief Morgan thanked Darryl, who leads a great small team, and thanked the team who faced the chaos. Chief Morgan discussed the flags bouncing back and forth between single and double red flags. Chief Morgan discussed the need for more education and prevention. Chief Morgan reported last year the City's 9 fulltime lifeguards and 2 seasonals entered the water 2,779 times to help people in distress. Chief Morgan further reported this year to date they had worked 27 actual rescues in addition to countless others for assists. Chief Morgan reported the team was working 7 days a week and working countless hours. Chief Morgan thanked the Police Department and the Code Enforcement Department for assisting, as well as the County.

Mayor Tette mer inquired as to the current staffing. Chief Morgan reported the same and further discussed having a hard time keeping seasonal staffing.

Councilman Casto commended Chief Morgan and staff for a great job and expressed condolences to the families who had lost loved ones. Councilman Casto reported that he has stood up over the years saying that perhaps this was the top issue over transportation facing Council. Councilman Casto discussed the accomplishments of the prior Safety Committee he and Chief Morgan were a part of. Councilman Casto added the City has made progress over the years; however, we can do better, and recommended that Council bring the Committee back to life to move the bar higher.

Councilman Register commended Chief Ray and his staff for a great job. Councilman Register agreed with Councilman Casto about bringing the Committee back to life. A brief discussion about double-red flag citations took place. Councilman Register noted he would defer to Chief Ray and his staff, the experts, and would support them as needed.

Chief Ray expressed concern for the team and his staff. Chief Ray reported that additional lifeguards would of course help, but how to fund additional lifeguards was up to Council.

**Vice Mayor Jarman recommended that Council hold a 4:00 p.m. workshop before Council's next meeting on July 25th. Councilmembers concurred.**

Councilmember Coburn noted she was grateful to Darryl and his team. Councilmember Coburn inquired if posting the drowning numbers would shock people into compliance. Councilmember Coburn noted it seemed that education was working. Chief Morgan discussed the incident behind Sharky's and people still going into the water during the lifesaving event.

Mayor Tette mer asked for the data on drownings on the Island for the past 10 years, dates, times, locations as well as visitor numbers and if the drowning victims were visitors or locals; options to prep for the workshop to increase beach safety, such as would spotters help, any immersing technology, Jacksonville's volunteer lifeguard, and why such little interest in the public/private partnership lifeguard program.

Chief Morgan reported the Boardwalk had been a great partner, however, with respect to other organizations, there was a myriad of issues as to why their boards voted down the program.

Mayor Tette mer further asked for costing of additional lifeguards, capital outlay, funding options and if it could be tied to commerce. Mayor Tette mer inquired if Council wanted to go forward with a motion for the workshop.

**Vice Mayor Jarman moved to hold a workshop on lifeguards and water safety at 4:00 p.m. on July 11, 2024. Councilman Casto seconded the motion. All were unanimously in favor of holding the workshop by a (5-0) roll call vote.**

Councilman Casto	Aye
Councilmember Coburn	Aye
Councilman Register	Aye
Vice Mayor Jarman	Aye
Mayor Tette mer	Aye

Mayor Tette mer asked if Council could have the data to review prior to the July 11<sup>th</sup> meeting. Chief Morgan thanked Council for their support.

Mayor Tette mer called for public comments.

1. Alfie Martin – Mr. Martin commented that nothing cures stupidity. Mr. Martin recommended that Council do a PSA about water safety and the beach flag system and perhaps it could be shown on TV stations for free and at short-term rentals. Mr. Martin recommended that the Arts Council help with the PSA to educate people.
2. Gary Wayne Beck – Mr. Beck commented that the government was trying to control free people trying to get in surf. Mr. Beck commented that he could create a surf rescue system to better our community. Mr. Beck asked Council to give him the opportunity to put a surf rescue system in place.
3. Genice Hatcher – Ms. Hatcher commented that Mr. Beck wants to help in some way so Council should let him help. Ms. Hatcher commented, in her opinion, that Council was putting too much power with the City Manager so they should take back their power. Ms. Hatcher encouraged Council to get more involved and she would get more involved.
4. Tom Campbell – Mr. Campbell commented that he was encouraged that Council would reinstate a water safety board. Mr. Campbell discussed the demographics who visit the Beach and their willingness and aversion to risk. Mr. Campbell thanked Council for giving this topic the attention it deserves.
5. Bill Caravello – Mr. Caravello commented that Council should use the Navy Base for services, training and/or perhaps they could supply resources to help with beach safety.

Vice Mayor Jarman reported, with respect to Ms. Hatcher’s comments that Council get involved in the city operations, Vice Mayor Jarman reminded everyone that it would be a violation of the City Charter and an ethics violation for individual council members to direct and/or monopolize staff and/or the city manager. Vice Mayor Jarman added whatever Council does that expends a great deal of time it needs to be done as a unit, that not one councilmember can start controlling city operations as it would be a Charter and state ethics laws violations.

**Mayor Tette mer recessed the meeting for 5 minutes at 10:54 a.m.**

**Mayor Tette mer called the meeting back to order at 11:01 a.m.**

**REGULAR AGENDA- DISCUSSION/ACTION ITEMS**

**ITEM 1. ORDINANCE NO. 1647, AMENDING CHAPTER 4, ARTICLE II, OF THE CITY’S CODE RELATED TO SPECIAL EVENTS; FIRST READING, PUBLIC HEARING.**

Mayor Tetteer invited Attorney Davis to comment. Mr. Davis read Ordinance 1647 by title only. Mr. Davis noted Council directed Staff at its last meeting to draft an amendment to the special events ordinance that would essentially make a second event a conditional use, add provisions for additional cell service, how a hearing would be conducted, due process, the process for appeals.

Mayor Tetteer opened the public hearing. Hearing and seeing no comments, Mayor Tetteer closed the public hearing.

Mayor Tetteer noted this item was available to Council and called for further discussion/amendments. **Vice Mayor Jarman moved to approve Ordinance 1647. Councilmember Coburn seconded the motion. All were unanimously in favor of approval of Ordinance No. 1647 by a (5-0) roll call vote.**

Councilman Casto	Aye
Councilmember Coburn	Aye
Councilman Register	Aye
Vice Mayor Jarman	Aye
Mayor Tetteer	Aye

**ITEM 2. ORDINANCE NO. 1648, COMPREHENSIVE PLAN - SANITARY SEWER ELEMENT PLAN AMENDMENT, FIRST READING / PUBLIC HEARING.**

Mayor Tetteer introduced Attorney Davis. Attorney Davis read Ordinance No. 1648 by title only. Mayor Tetteer invited Director Leonard to comment.

Director Leonard reported the State of Florida requires that local governments update its Sanitary Sewer Element of their Comprehensive Plans to include an analysis of septic tank conversions to sanitary sewer. Director Leonard reported further that the Planning Board considered the proposed updates to the Sanitary Sewer Element at its June 12<sup>th</sup> meeting and recommended approval by a vote of (6-0). Director Leonard notice the Board recommended including the historical and projected average daily wastewater production amounts be updated as well as a new Objective 8 and new Policy 8.1 to plan for expansions to meet future demand. Director Leonard reported that, if approved by Council, this would be submitted to the State for comments and then brought back to City Council for a second reading and approval.

Mayor Tetteer opened the public hearing. Hearing and seeing no comments, Mayor Tetteer closed the public hearing.

Mayor Tetteer noted this item was available to Council. **Vice Mayor Jarman moved to approve Ordinance 1648. Councilman Register seconded the motion. All were unanimously in favor of approval of Ordinance No. 1648 by a (5-0) roll call vote.**

Councilman Casto	Aye
Councilmember Coburn	Aye
Councilman Register	Aye
Vice Mayor Jarman	Aye
Mayor Tetteer	Aye

**ITEM 3. DRAFT ORDINANCE NO. 1649 FOR DISCUSSION, AMENDING CHAPTER 5, ARTICLE II, RELATED TO ANIMAL CONTROL.**

Mayor Tette mer introduced Attorney Davis. Attorney Davis read draft Ordinance No. 1649 by title only.

Attorney Davis reported this draft was prepared per Council’s direction during the June 13. Attorney Davis added the Ordinance was drafted to remove licensing for cats and dogs and render the permit requirements for livestock and fowl less burdensome for property owners seeking to keep these animals on their property with the permission of their neighbors, it removes old language requiring licensing for cats and dogs and proposes that the written permission of neighboring owners be valid unless and until revoked, instead of automatically expiring annually and requires new written permission be obtained, as well as roosters not be permitted.

Councilman Register noted basically that this seemed very complicated and to him less government was a better government and further discussed the complicated provisions. Councilman Register recommended that this ordinance be scaled back. Mayor Tette mer discussed the pros of proceeding with the ordinance as drafted. Vice Mayor Jarman and Councilmember Coburn spoke in favor of removing pigs. Attorney Davis briefly reviewed the current nuisance code and detailed ordinance on pot-bellied pigs. Further discussion regarding health and safety issues and the current number of dogs and cats permitted took place.

Mayor Tette mer recommended moving the ball down the road, possibly tweaking it. Vice Mayor Jarman asked for clarification – was Councilman Register and Mayor Tette mer both ok with doing away with the licensure of cats and dogs. Both concurred. Discussion regarding falling back on the nuisance law took place. Manager Whitman discussed the current permission to be approved for chickens took place. Councilmember Coburn discussed the length of time typically it takes to cure a problem. Attorney Davis discussed the criteria, days to cure, the letter being sent, etc. Further discussion regarding tweaking the ordinance took place.

Mayor Tette mer called for public comments. Hearing and seeing none, Mayor Tette mer closed the public comment period.

Mayor Tette mer noted this item was available to Council. **Vice Mayor Jarman moved that Staff move forward with drafting the ordinance as presented, except for in Section 5-3(a) exchange “60 days to dispose to..” “30 days to dispose...” and remove the “or the City Manager” with respect to the cancellation of licensure. Councilman Register seconded the motion. All were unanimously in favor of approval of the motion by a (5-0) roll call vote.**

Councilman Casto	Aye
Councilmember Coburn	Aye
Councilman Register	Aye
Vice Mayor Jarman	Aye
Mayor Tette mer	Aye

**ITEM 4. RESOLUTION NO. 24-149, APPROVING AN AGREEMENT WITH CW ROBERTS CONTRACTING, INC. FOR THE PURCHASE OF HOT MIX ASPHALT AND PAVING MATERIALS AT SET UNIT PRICES.**

Mayor Tette mer introduced Attorney Davis. Attorney Davis read Resolution 24-149 by title only. Mayor Tette mer invited Director Mark Shaeffer to the podium.



Director Shaeffer explained this resolution would approve the purchase of asphalt materials so staff could make these smaller repairs, as the previous Council approved the purchase of equipment to make start marking these repairs.

Mayor Tette mer called for public comments. Hearing and seeing none, Mayor Tette mer closed the public comment period.

Mayor Tette mer called for comments from Council. **Councilman Casto moved to approve Resolution 24-149. Councilmember Coburn seconded the motion. All were unanimously in favor of approval of Resolution No. 24-149 by a (5-0) roll call vote.**

Councilman Casto	Aye
Councilmember Coburn	Aye
Councilman Register	Aye
Vice Mayor Jarman	Aye
Mayor Tette mer	Aye

**ITEM 5. RESOLUTION NO. 24-150, APPROVING AN AGREEMENT WITH RAFTELIS FINANCIAL CONSULTANTS, INC. FOR A MUNICIPAL IMPACT FEE STUDY; AND AUTHORIZING A BUDGET AMENDMENT.**

Mayor Tette mer introduced Attorney Davis. Attorney Davis read Resolution No. 24-150 by title only. Mayor Tette mer invited Assistant Manager White to comment.

Assistant Manager White explained that at the City Council meeting in May Councilman Jarman recommended, and the Council directed Staff, to move forward with updating the municipal services impact fees. Ms. White explained further that the last Municipal Services Impact Fee Study was performed by Public Resources Management Group in 2018 and in 2019, and since then Raftelis had acquired PRMG. Assistant Manager White further reported that Staff requested a proposal from Raftelis to update the Municipal Impact Fee Study and the municipal services to be included in the study would be police, fire, library, and parks and recreation. Ms. White added a budget amendment for this work was included Council’s packet since this was not budget in the FY2024 budget.

Mayor Tette mer inquired as to why certain sections of the agreement were marked out. Attorney Davis reported by resolution the Council directed Staff to not indemnify contractors and generally as the City Attorney we don’t recommend arbitration so if approved we will go back to the contractor and work those sections out. Councilmember Coburn inquired if this could be done sooner than six months. Assistant Manager White Holly reported that Staff would ask, however, it was highly unlikely since it was quite a data driven effort.

Mayor Tette mer called for public comments. Hearing and seeing none, Mayor Tette mer closed the public comment period.

Mayor Tette mer called for comments from Council. **Vice Mayor Jaman moved to approve Resolution 24-150. Councilmember Coburn seconded the motion. All were unanimously in favor of approval of Resolution No. 24-150 by a (5-0) roll call vote.**

Councilman Casto	Aye
Councilmember Coburn	Aye
Councilman Register	Aye
Vice Mayor Jarman	Aye
Mayor Tette mer	Aye

**ITEM 6. DISCUSSION / ACTION ITEM, BOARD APPOINTMENT.**

Mayor Tette mer asked Attorney Davis to comment. Attorney Davis reported this was a continuation of the airport board appointment as Council was deadlock at its last meeting. Attorney Davis explained the process and noted this appointment was set by special law and the appointment process was up to the Council and does not require public comment.

Mayor Tette mer called for comments from Council.

Vice Mayor Jarman echoed his comments made at the previous Council meeting and clarified that the Airport Board was more of an economic development board, and he would be looking for diversity of individuals on the board. Vice Mayor Jarman noted he was not looking for another airport employee to go on board and he would not let any personal animus cloud his judgement.

Mayor Tette mer noted there were a few new applicants after the process was opened back up and his second pick last time around was Ron Pezley and of the new candidates his preference would be Bob Fletcher. Mayor Tette mer spoke about Mr. Fletcher’s qualifications. Mayor Tette mer reported he liked Ron and Bob.

**Vice Mayor Jarman moved to reappoint Mark Sheldon to the Airport Board. Councilman Register seconded the motion.** Mayor Tette mer asked Ms. Fasone to call the roll. Mark Sheldon was appointed to the Airport Board by a roll call vote of (3-2).

Councilman Casto	Aye
Councilmember Coburn	No
Councilman Register	Aye
Vice Mayor Jarman	Aye
Mayor Tette mer	No

**CITY MANAGER REPORT** –Manager Whitman thanked the public safety team for all of their hard work, especially during the recent water safety calls.

**CITY ATTORNEY REPORT** – Attorney Davis recommended some procedural tweaks to the double red flag ordinance and further discussed the triggers for enforcement. Attorney Davis reported that he would bring something back to Council for consideration. Mayor Tette mer called for any objections from Council. Hearing and seeing none. Attorney Davis recommended that he bring the ordinance to Council as a first reading, since it was the season. Attorney Davis also recommended that he bring to Council an update to Council’s rules and procedures, now that the new Council had a few meetings under their belts. Councilmembers concurred.

**COUNCIL COMMENTS** – Mayor Tette mer called for comments from Council.

Councilman Casto commended the City’s water safety team. Councilman Casto encouraged Councilmembers to think about who they would like to put on that water safety board.

Attorney Davis clarified, back in the day Council had a Water Safety Board in Chapter 7, which was done away with during the recent amendments to Chapter 7, as well as, Council created a Public Safety Board by Resolution that could be revived quickly. All Councilmembers concurred.

Councilman Register commended Chief Talamantez on the way he handled an adverse situation. Councilman Register added unfortunately, the Governor was a week late passing his Bill, however, we now have a way to protect our leaders. Councilman Register also commended Manager Whitman on doing

what was required and offered his appreciation. Councilman Register thanked Chief Ray and his team for keeping residents and visitors safe. Councilman Register added that public safety was number one and he would do whatever it takes to turn this into the World's safest beaches.

Councilmember Coburn echoed Councilman Register's comments and thanked all employees for working so hard for the city.

Vice Mayor Jarman echoed those sentiments about the first responders. Vice Mayor Jarman noted he had been looking at what types of things he could do to make a positive impact. Vice Mayor Jarman noted he had been doing research on voter participation. Vice Mayor Jarman discussed low voter participation in April versus higher voter turnout in November. Vice Mayor Jarman recommended Council weigh in on moving elections to the November election cycle. Vice Mayor Jarman discussed the benefits of moving elections to the November election cycle. Vice Mayor Jarman noted that he had talked with the Supervisor of Elections, Ms. Ward, and she said she would do whatever this Council decides. Vice Mayor Jarman noted if agreed, the change can be made by ordinance, not a referendum. Vice Mayor Jarman added if agreed he would like Council to direct staff to start working in that direction.

Councilman Register commented how could you not be in favor of greater voter turnout. Councilman Register inquired as to how the change might effect this Council's terms. Vice Mayor Jarman reported everyone up here would have their term extended to November.

Councilman Casto reported one of the previous Councils had tried this, however it was denied by the previous Superintendent because of cost. Vice Mayor Jarman noted that it would fall under the general election funding. Councilman Casto noted the change makes sense.

Councilmember Coburn noted she would like to see the costs involved. Vice Mayor Jarman reported the City spent about \$20,000 for the April election. Manager Whitman concurred. Councilmember Coburn asked if Staff would please verify that the City would not be charged.

Attorney Davis clarified that per the election code, Council could pass an ordinance to change qualifying and to deal with any consequences of those changes, including extending terms, and the Council would need to make that decision.

Mayor Tetterer noted he was all in favor of additional participation, however, one issue he sees is members running unopposed. Mayor Tetterer recommended Council look at a charter change to move to ward-by-ward voting. Council further discussed the pros and cons of ward-by-ward voting, the cost to run a campaign and Councilmembers representing the entire city, not just wards.

**Mayor Tetterer inquired if Council was fine with seeing what it takes to move elections to November. All Councilmembers concurred. Attorney Davis inquired if Council was directing him to prepare an ordinance. Councilmembers recommended that Staff draft an ordinance for Council to review. Councilman Casto inquired about the timeline. Vice Mayor Jarman noted that Council had time, the next city election was 2026.**

Mayor Tetterer expressed Council's condolences for those who lost loved ones in the Gulf. Mayor Tetterer echoed his support for Chief Talamantez and the PD. Mayor Tetterer congratulated Public Works and the CRA for getting those lanes switched over. Mayor Tetterer reported the traffic impact at Back Beach Road and Powell Adams should be done in about 3-4 months, while not a City project, Council understands the impact. Mayor Tetterer wished everyone a happy Independence Day and asked for God's guidance and protection.

With nothing further, Mayor Tetterer adjourned the meeting by unanimous consent at 12:04 p.m.

READ AND APPROVED this 11<sup>th</sup> day of July, 2024.



Stuart Tetterer, Mayor  
City of Panama City Beach, Florida

ATTEST:



Lynne Fasone, MMC, City Clerk

\* ACTION ITEMS NOTED WITH AN ASTERISK ARE TAKEN BOTH BY THE CITY COUNCIL AND THE PANAMA CITY BEACH REDEVELOPMENT AGENCY JOINTLY AND CONCURRENTLY. IN THE EVENT OF A CONFLICT BETWEEN THE FOREGOING MINUTES AND A VERBATIM TRANSCRIPT OF THESE MINUTES, THE FOREGOING MINUTES SHALL CONTROL.

**“Panama City Beach:  
A Health Care Destination”**

Panama City Beach-City  
Council

August 25, 2022



# Timeline of Opportunity

The process and timeline to get to our current position started back in 2020. TMH and FSU spent ample time on the DISCOVERY & RESEARCH component of the overarching process.

DISCOVERY &  
RESEARCH  
August 2020-  
January 2021

SUBMISSION  
February 2021

FSU/TMH  
AWARDED  
OPPORTUNITY  
APRIL 2021

PHASE I  
May 2021-  
December 2024

# CURRENT STATE

## Regional Trends

- Effects of Hurricane Michael
  - Hurricane Michael caused significant healthcare infrastructure damage which has affected the volume of providers in the market as well as patients' access to care.
  - Significant and ongoing population growth is now focused on Bay and Walton Counties.
- Key Infrastructure Changes
  - The number of bookings through ECP Northwest Florida Beaches airport has reached over one million seats per year. As a result, the region is realizing an influx of not just new vacation guests but also new permanent residents.
  - Home purchases are increasing across all age groups, from early and mid-career professionals to early retirees, as evidenced through the construction of Origins, Latitude, and Camp Creek.
  - The Marina at Port St. Joe has a path for further development.
  - The new roads crossing SR 79 and running along the Gulf Coast Intracoastal Waterway will further stimulate home construction and growth of local commerce.

# CURRENT STATE

## Healthcare Landscape Surrounding Proposed Location

- Located in Bay County, west of Panama City and near the Highway 30A corridor and 7.5 miles from Northwest Florida Beaches International Airport
- The nearest hospitals to the development lie in a driving radius of 30-45 minutes, and include:
  - Gulf Coast Regional Medical Center
  - Bay Medical Sacred Heart
  - Sacred Heart on the Emerald Coast (Destin)
  - Doctor's Memorial
  - Healthmark Regional Medical Center

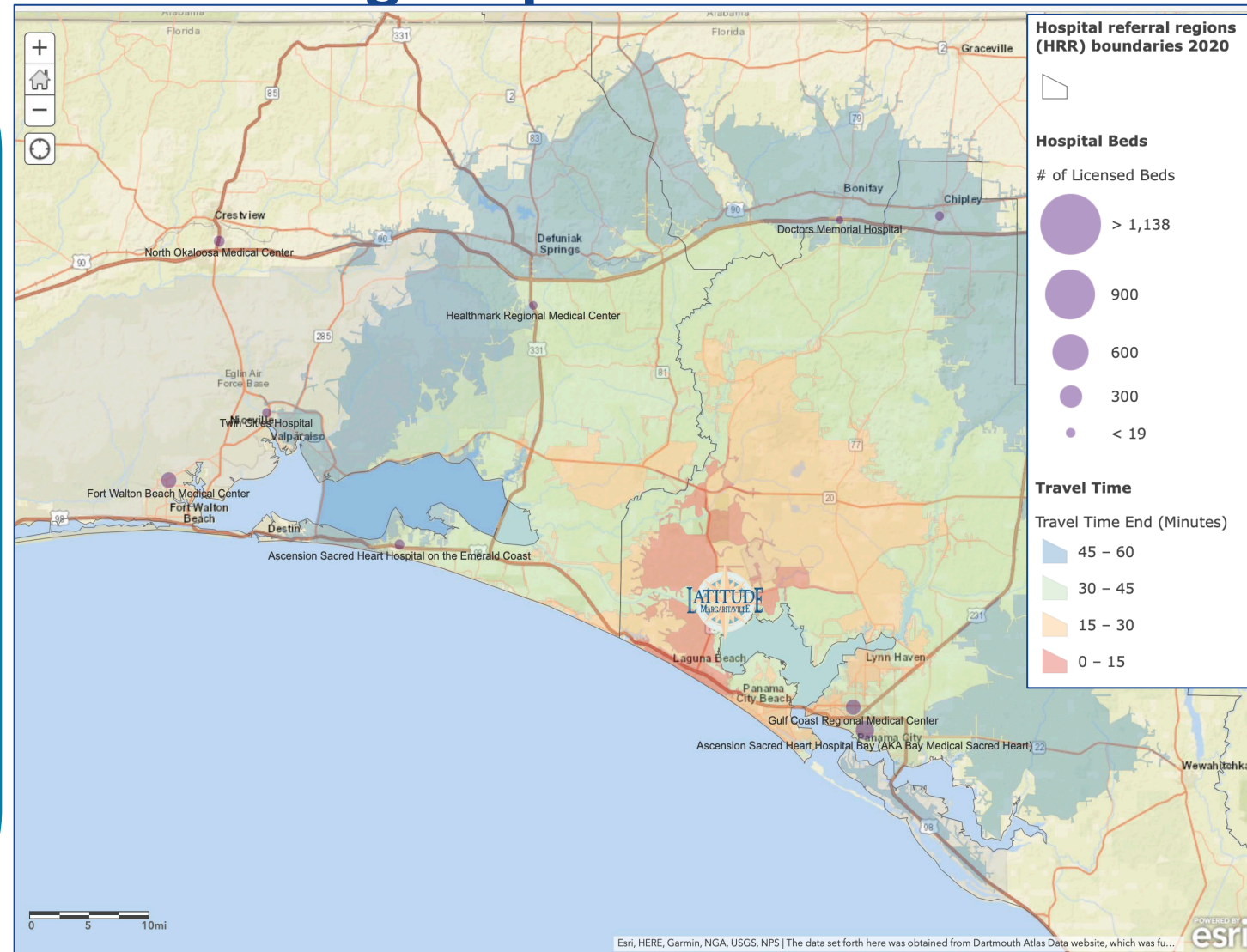



# CURRENT STATE

## Community

Comparing population growth between 2020 and 2025, zip codes in Walton County, as well as the zip code encompassing Latitude Margaritaville (32413), will provide the most consequential growth.

The zip codes with the highest numbers of population will be centered around Panama City and the coastal areas along the Gulf of Mexico.

Bay County population increases from 174,728 in 2020 to 180,765 in 2025 (3.5% change)

The immediate four surrounding counties (Walton, Washington, Calhoun, and Gulf) have a 2020 population of 130,507, increasing to 141,729 in 2025. Growth will occur largely in Walton County.

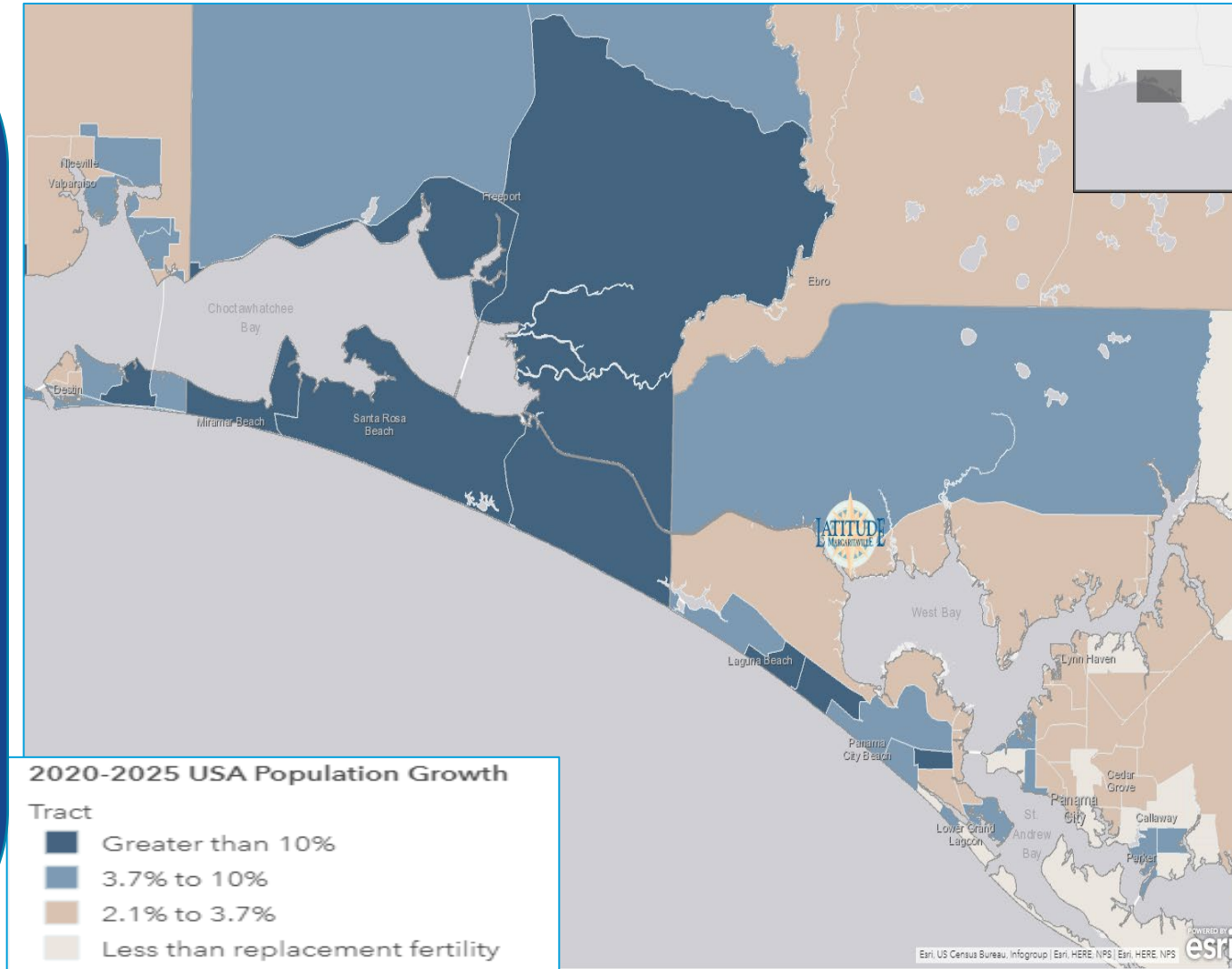

**Why does TMH make  
sense as the partner for  
Bay County?**



# PANAMA CITY BEACH

## Priorities

### Community Engagement/ Partnership

- The future partner must have local engagement
- The future partner must be embedded into the community; “not looking for a building with a shingle”
- A partner with track record

### Education & Human Capital

- Successfully recruit and develop elite medical professionals
- Develop research and other diversified programs that have educational and commercial opportunities
- Develop programs with regional and state educational institutions

### Unique Medical Destination (Not Just a Hospital)

- Focus will be on a healthcare “destination”.
- Based on vast current and future client base, a portfolio of services must be part of the plan.

### Contributor to PCB Goals

- Future partner must create jobs
- Offer a destination that supports Panama City Beach as a destination for population and economic growth

# TMH: The Right Partner

## Our Organization

*The Mission and Vision of  
Tallahassee Memorial HealthCare*

### Our Mission

*Transforming care.  
Advancing health.  
Improving lives.*

### Our Vision

*To be known as the most  
engaged and supportive  
organization in America.*

Since its founding, TMH has focused on developing programs and services to better serve its community

Founded in 1949, Tallahassee Memorial Hospital (TMH) is a private, not-for-profit community healthcare system committed to transforming care, advancing health, and improving lives with an ultimate vision to elevate the standards of our healthcare practice, quality and innovation in the region.

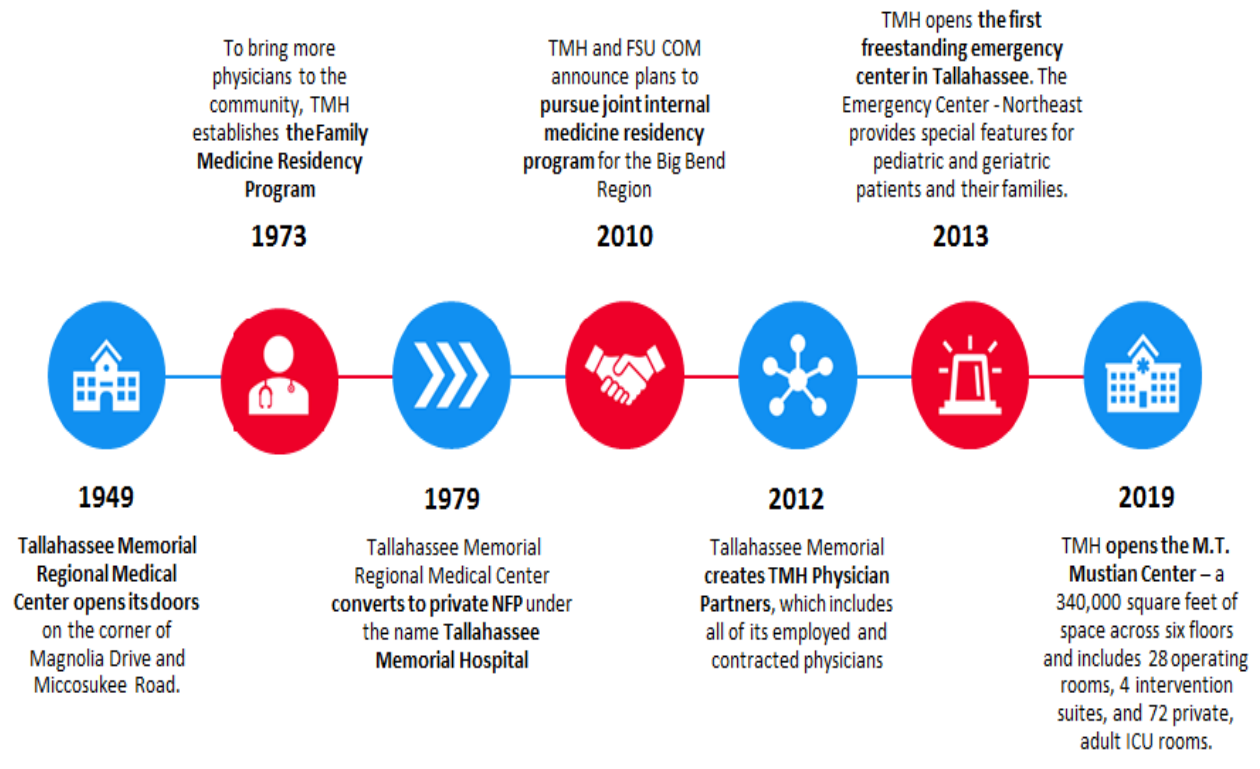

# TMH: The Right Partner

## *Our System Coverage*

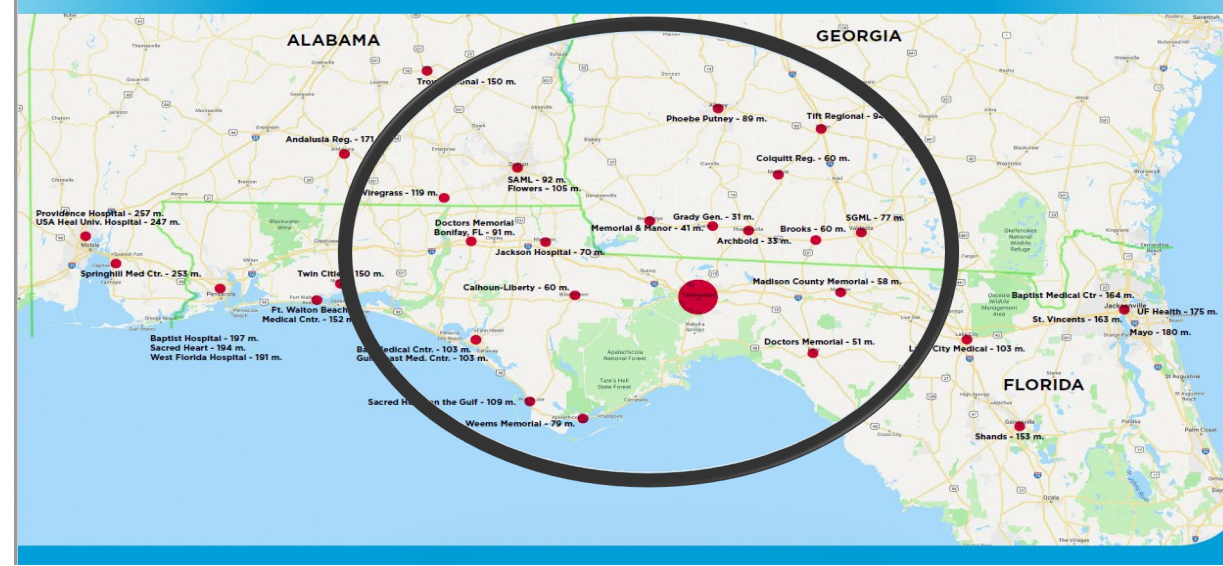

- **772-bed acute care hospital**
- **Our facilities:**
  - 2 Emergency Centers (1 freestanding)
  - 2 Urgent Care Centers (and growing)
  - 2 Outpatient Surgery Centers
  - Cancer Center
  - Behavioral Health Center
  - Rehabilitation Center
  - Home Health Care

- **Serving 20+ counties in the Panhandle**
  - Not-for-profit healthcare system
  - Largest private employer in Leon County
  - 5,500+ colleagues
  - 250+ employed physicians; 1,000+ Medical Staff
  - 35+ outpatient practices in 9 (soon 10) counties
  - 3 physician residency programs

# TMH: The Right Partner

## Quality & Diversification of Services



### High Performing in:

- COPD
- Colon cancer surgery
- Diabetes
- Heart attack
- Heart failure
- Kidney failure
- Stroke

#### Behavioral Health

Expert adult and pediatric mental health care to treat substance use disorder, mood and anxiety disorders and more through a collaborative team of psychiatrists, psychologists, nurses, social workers and other mental health professionals.

#### Emergency

With two emergency centers and the largest team of board-certified emergency medicine physicians in the region, TMH is ready for any emergency.

#### Orthopedic

Home to the most experienced orthopedic team in the area with custom joint replacement procedures, orthopedic trauma care and compassionate rehabilitation.

#### Cancer

The most powerful cancer program in the Big Bend region is also the longest continuously accredited comprehensive community cancer program in Florida.

#### Heart & Vascular

A top complex and comprehensive cardiovascular program in the Southeast with the area's only Structural Heart, Heart Rhythm, Heart Failure and Cardio-Oncology Programs.

#### Surgery

Largest and most experienced surgical team in the region, utilizing a state-of-the-art facility, revolutionary technology, including robotics, and techniques tailored for each individual patient.

#### Children

The Children's Center is affiliated with Wolfson Children's Hospital. Home to the only Pediatric Intensive Care Unit and Certified Child Life Specialists.

#### Neuroscience

The Panhandle's most advanced neurosurgery program with the only Comprehensive Stroke Center and Neurological Intensive Care Unit.

#### Trauma

The only Level-II Trauma Center in the region with the area's highest accreditations, including a Comprehensive Stroke Center and Chest Pain Center with PCI and Resuscitation.

#### TMH Physician Partners

More than 35 primary and specialty care practices available across seven counties, TMH Physician Partners is a vast network of medical providers offering exceptional patient care.

#### Women & Babies

The region's first and only accredited Baby-Friendly Hospital, focused on building better bonds between moms and babies. Home to the area's only high-risk Labor and Delivery and Level III Neonatal Intensive Care Unit.

# TMH: The Right Partner

## *TMH-A Track Record of Partnerships*

Tallahassee Memorial has been successful in developing organizational relationships in both education and portfolio development. The beneficiaries of these relationships remain our patients who realize world-class healthcare without having to leave their home

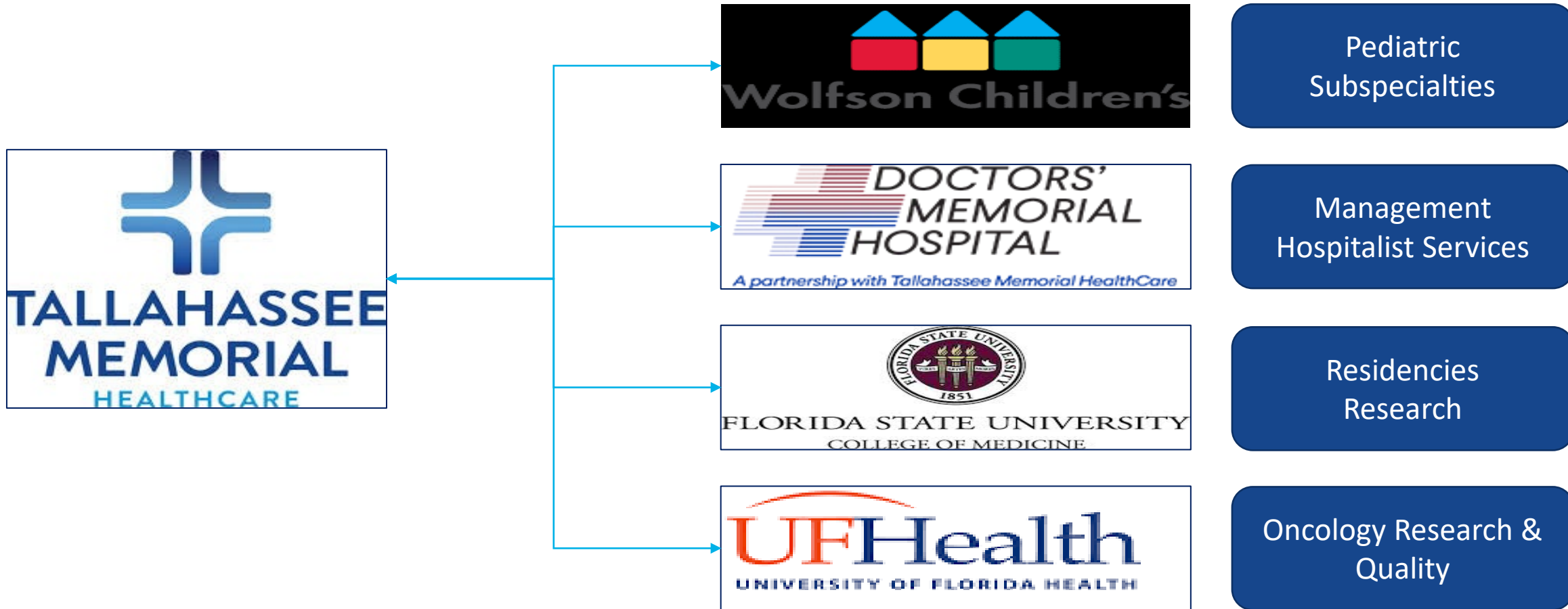

# FSU & TMH: The Right Partner

## *TMH-A Successful & Proven Academic Partner*

Tallahassee Memorial has served as a destination for residency and other key training programs. While TMH and FSU have developed two nationally recognized residency programs, both institutions are actively exploring greater synergies, including the development of an Academic Medical Center.

SPECIALITY	NUMBER OF YEARLY RESIDENTS
<b>Internal Medicine</b>	<b>9</b>
<b>General Surgery</b>	<b>2</b>
Family Medicine	10
Pharmacy	2
Nursing	~30
Family Medicine-OB Fellowship	1

***\*-Associated with FSU College of Medicine***

TMH's oldest residency program is Family Medicine. This program was developed independently over 40 years ago.

In addition to physician training programs, TMH has been successful with other key disciplines including Pharmacy and Nursing.



# FSU & TMH: The Right Partner

## FSU-Track Record of Recruitment & Retention

The competition for physician resources will continue to grow. For communities to realize ongoing physician and medical presence, they must identify regional, academic opportunities.

By establishing a local FSUCOM relationship, a phased program can develop to not only offer immediate educational and training opportunity, but build the foundation for years to come.

Allopathic Medical School Ranked by 2019 Enrollment	1. University of Miami	2. USF Health Morsani	3. University of Florida	4. Florida International University	5. University of Central Florida	6. Florida State University	7. Florida Atlantic University	8. Nova Southeastern University
Location	Miami	Tampa	Gainesville/Jacksonville	Miami	Orlando	Tallahassee	Boca Raton	Davie
Campus Type	Urban	Urban	Suburban	Urban	Suburban	Urban	Urban	Urban
School Type	Private	Public	Public	Public	Public	Public	Public	Private
Total Enrollment	872	732	602	498	499	480	266	104
# of In-state Applicants (%)	2,185 (24%)	2,430 (44%)	2,346 (52%)	2,491 (53%)	2403 (47%)	2,773 (39%)	2,178 (61%)	1,911 (37%)
# of In-state Matriculants (%)	115 (56%)	117 (64%)	120 (88%)	99 (81%)	81 (68%)	116 (97%)	28 (42%)	30 (59%)

There are **eight allopathic medical schools** in Florida.

FSU COM receives the highest number of **in-state applicants** and matriculates the highest percentage of in-state students

		FL	FL Rank
Physician Retention	Percentage of Physicians Retained in State from Undergraduate Medical Education, 2018	48.0%	10
	Percentage of Physicians Retained in State from Graduate Medical Education, 2018	58.3%	5
	Percentage of Physicians Retained in State from UME and GME Combined, 2018	78.6%	5

Florida is among the **top five states in the country for retaining physicians** that train in Florida for GME, with 58% of physicians practicing in Florida after residency.

**Physician retention rates (79%)** were even higher among physicians who completed both medical school and residency in Florida.

**Of the 768 FSU COM alumni who have completed their residency, 56% (432) are practicing in Florida or a Florida border county and 6% (47) are practicing in Tallahassee.**

# Timeline of Opportunity

Following the pursuit and awarding of the Panama City opportunity, all efforts have turned to Phase I of the initiative.

Phase I will primary consist of Establishing Primary & Urgent Care, Campus Planning and Design & Initial Hospital Campus Planning and Design.

DISCOVERY &  
RESEARCH  
August 2020-  
January 2021

SUBMISSION  
February 2021

FSU/TMH  
AWARDED  
OPPORTUNITY  
APRIL 2021

PHASE I  
May 2021-  
December 2024

# TMH/ST. JOE-High Level Milestones

TMH and St. Joe are working through an overarching Master Plan, however, projected key milestones for development include, but not limited to:

- Phase I (Years 1-2)
  - Establish a primary and urgent care location that meets the family, wellness and urgent care needs of the immediate population
  - FSU will embark on an 18-24 month assessment of potential research and educational opportunities
  - Master design, plan and potentially begin build of the future hospital.
- Phase II (Years 3-5)
  - Realize “phase one” of the future hospital. This would include an minimum 30-40 inpatient beds, coupled with a comprehensive procedural center and an on-site Emergency Center
  - The FSU College of Medicine will establish additional research initiatives in the regional area. While opportunities may vary, a strong focus will be on healthy aging and lifestyle interventions

# FSU HEALTH-Master Campus Design

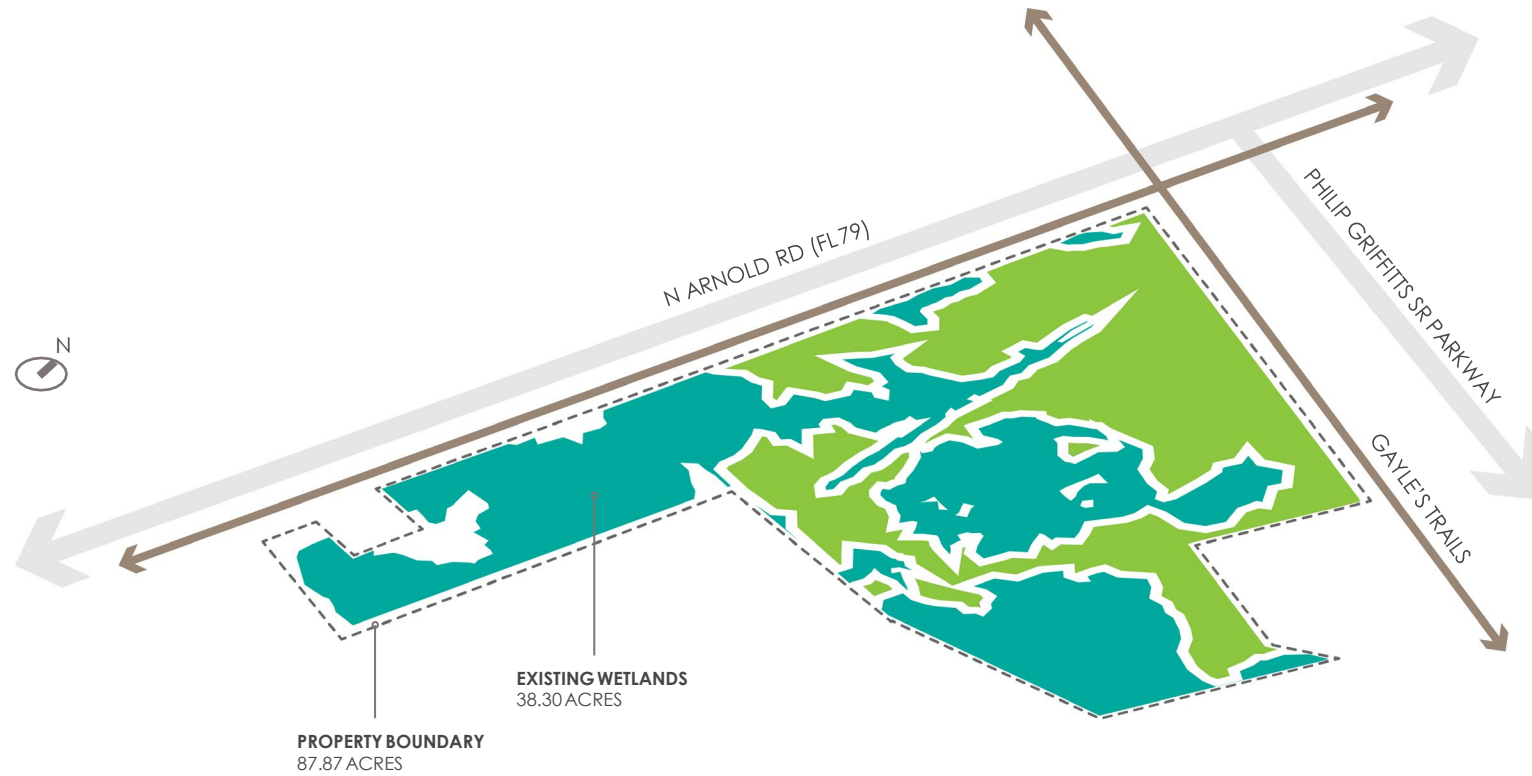

EXISTING SITE CONDITIONS

# FSU HEALTH-Master Campus Design



SITE DATA	
Site Area	= 87.87 Acres
Phase 1A	= 10.95 Acres
Phase 1B	= 29.23 Acres
<hr/>	
<b>Hospital Phase 1</b>	<b>= 330,000 BGSF</b>
Patient Beds	= 100 Beds
Parking Required	= 500 Spaces
(5 per Bed @ 100 Beds)	
<b>Medical Office Building 1</b>	<b>= 80,000 BGSF</b>
Parking Required	= 400 Spaces
(5 per 1,000 SF)	
<b>Total Parking Required</b>	<b>= 900 Spaces</b>
<hr/>	
Surface Parking	= 914 Spaces

SITE PLAN | PHASE 1B - 100 BED

# FSU HEALTH-Master Campus Design

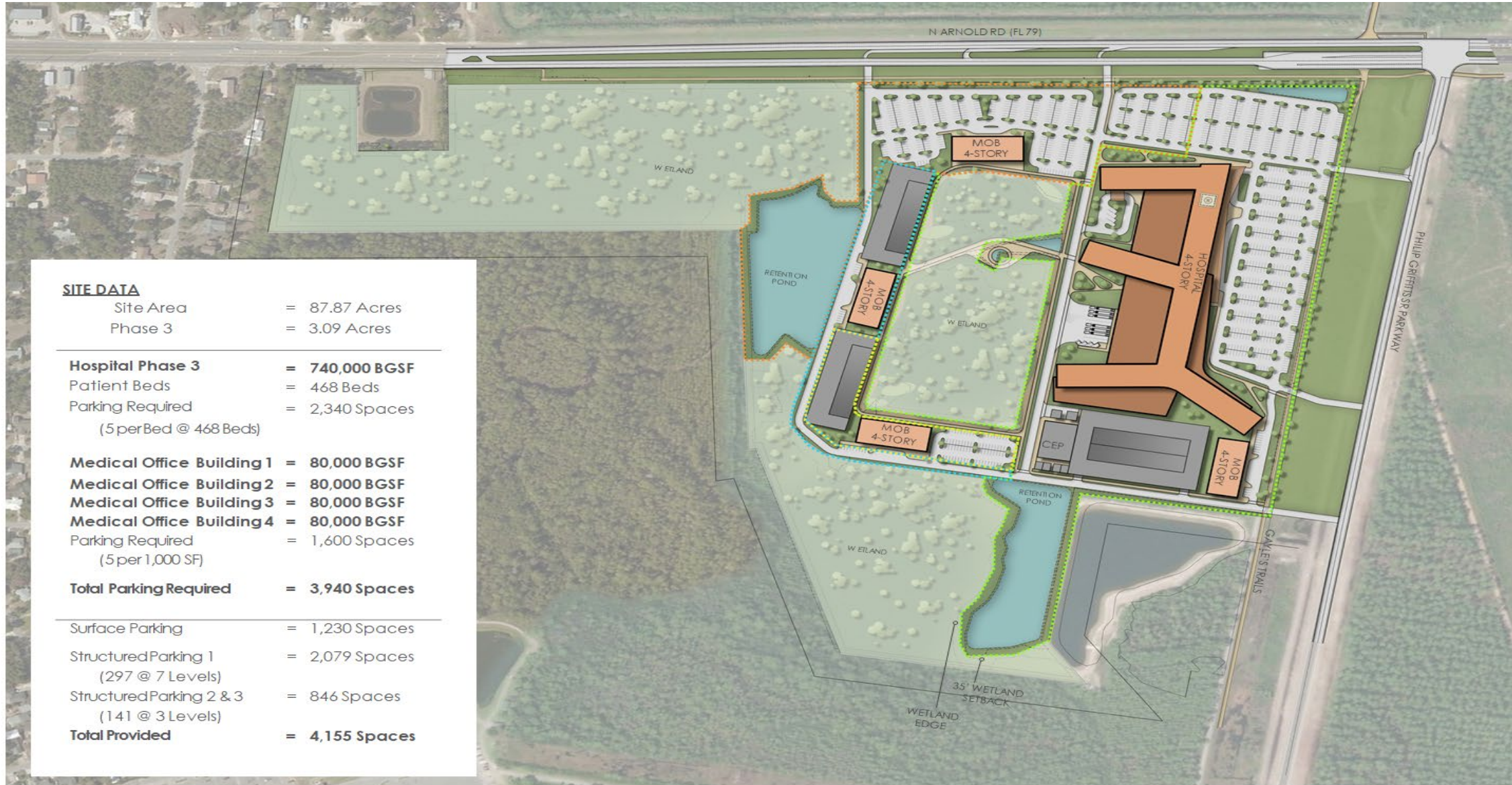

<b>SITE DATA</b>	
Site Area	= 87.87 Acres
Phase 3	= 3.09 Acres
<hr/>	
<b>Hospital Phase 3</b>	<b>= 740,000 BGSF</b>
Patient Beds	= 468 Beds
Parking Required	= 2,340 Spaces
(5 per Bed @ 468 Beds)	
<hr/>	
<b>Medical Office Building 1</b>	<b>= 80,000 BGSF</b>
<b>Medical Office Building 2</b>	<b>= 80,000 BGSF</b>
<b>Medical Office Building 3</b>	<b>= 80,000 BGSF</b>
<b>Medical Office Building 4</b>	<b>= 80,000 BGSF</b>
Parking Required	= 1,600 Spaces
(5 per 1,000 SF)	
<hr/>	
<b>Total Parking Required</b>	<b>= 3,940 Spaces</b>
<hr/>	
Surface Parking	= 1,230 Spaces
Structured Parking 1	= 2,079 Spaces
(297 @ 7 Levels)	
Structured Parking 2 & 3	= 846 Spaces
(141 @ 3 Levels)	
<hr/>	
<b>Total Provided</b>	<b>= 4,155 Spaces</b>

SITE PLAN | PHASE 3 - 468 BED

# Questions?

Andrew Starr, MBA, MHSA, FACHE  
Chief Health Operations Officer

Email: [andrew.starr@tmh.org](mailto:andrew.starr@tmh.org)

Tallahassee Memorial HealthCare, Inc.

1300 Miccosukee Rd.

Tallahassee, FL 32308

Phone: 850-431-3009

Mobile: 440-339-4340

Fax: 850-431-6681



# Street Resurfacing FY 2024

Clarence Street  
And Future Asphalt  
Rejuvenation



# Location of Clarence Street

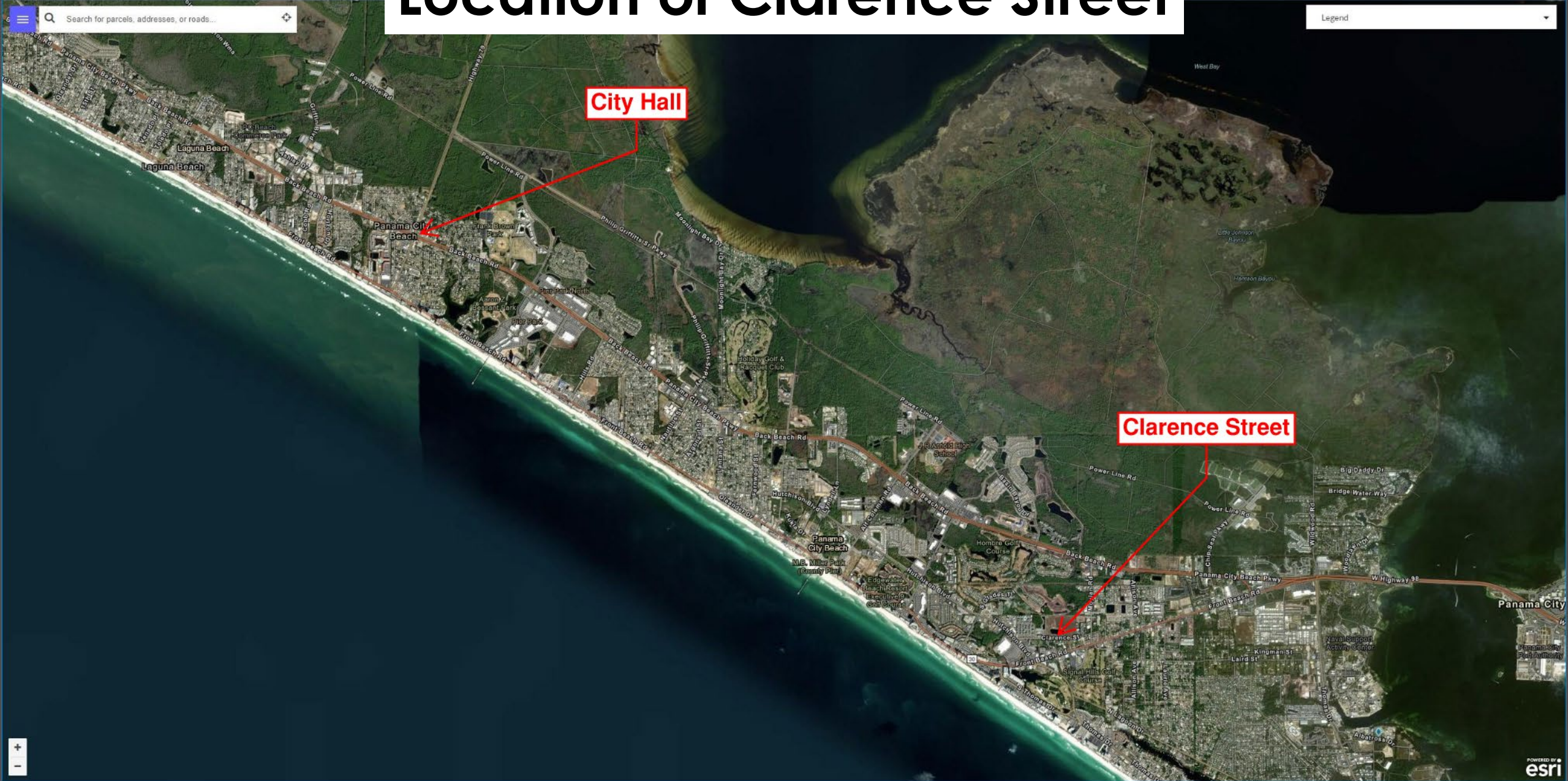

City Hall

Clarence Street

# Clarence Street



Search Google Maps

10320 Clarence St  
Panama City Beach, Florida

Google Street View

Aug 2023 See more dates

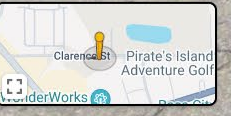

Google

Search Google Maps

9400 Clarence St  
Panama City Beach, Florida  
Google Street View  
Aug 2023 See more dates

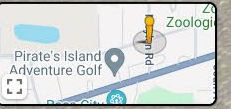

Google

Search Google Maps

9501 Clarence St  
Panama City Beach, Florida  
Google Street View  
Aug 2023 See more dates

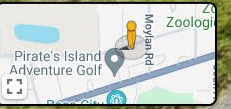

Google

# Current Conditions ·vs· Proposed

	<b>Current Condition</b>	<b>Proposed Condition</b>
Standards	?	Green Book, LDC, MUTCD
Lane Width	9 Feet	11 Feet
Pavement Thickness	2-5/8 to 3-3/4 Inches	2-1/2 Inches
Base Materials	Sand-Clay Mix	Crushed Concrete
Base Thickness	5 to 7 inches	8 inches
Sub-Base	None	12 inches
Striping	Only in Middle Beach ROW	Full MUTCD

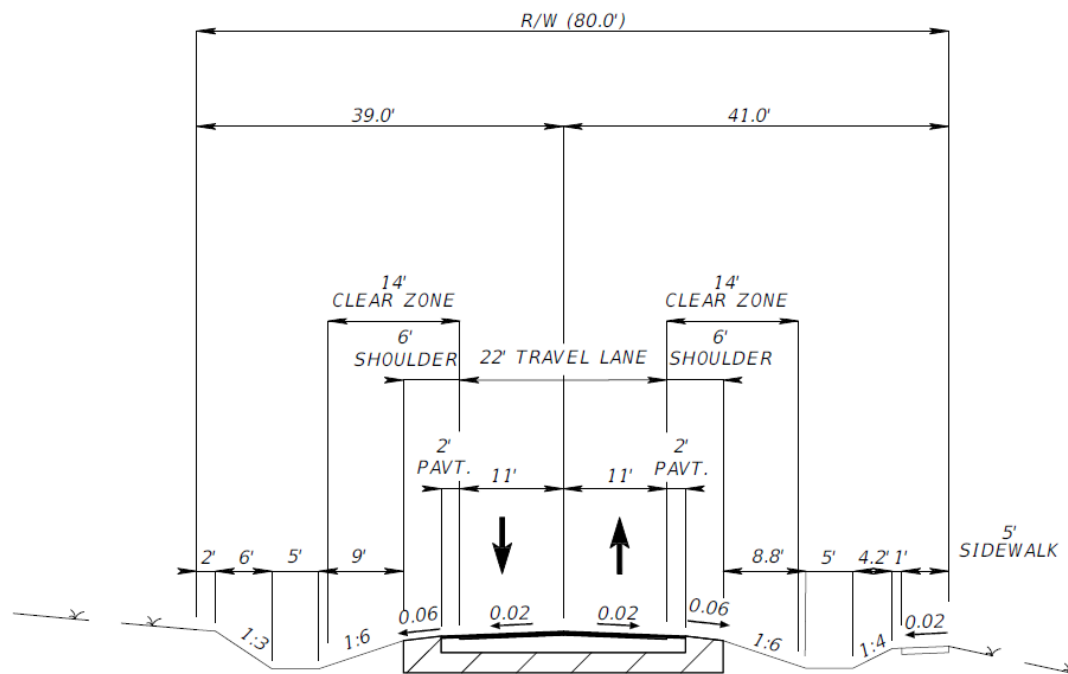

TYPICAL SECTION - 3  
CLARENCE STREET & SIDEWALK  
STA: 64+80.70 TO 77+95.03

NEW CONSTRUCTION  
2.5" SP 12.5 TRAFFIC LEVEL C  
8" THICK GRADED AGGREGATE BASE  
12" TYPE B STABILIZATION

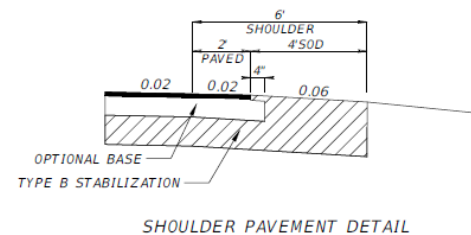

TRAFFIC DATA

CURRENT YEAR =  
ESTIMATED OPENING YEAR =  
ESTIMATED DESIGN YEAR =  
K = % D = % T = % (24 HOUR)  
DESIGN HOUR T =  
  
CONTEXT CLASS = C4  
DESIGN SPEED = 35 MPH  
POSTED SPEED = 25 MPH

REVISIONS			
DATE	DESCRIPTION	DATE	DESCRIPTION

BLAKE R. FURBEE, P.E.  
P.E. LICENSE NUMBER 88505  
GORTMOLLER ENGINEERING, INC.  
708 THOMAS DRIVE  
PANAMA CITY BEACH, FL 32408  
REGISTRY NO. 09505



CITY OF PANAMA CITY BEACH

PROJECT	COUNTY	PROJECT NO.
CLARENCE STREET	BAY	23-041

TYPICAL SECTIONS

SHEET NO.

5

THE OFFICIAL RECORD OF THIS SHEET IS THE ELECTRONIC FILE DIGITALLY SIGNED AND SEALED UNDER RULE 61G15-23.004, F.A.C.

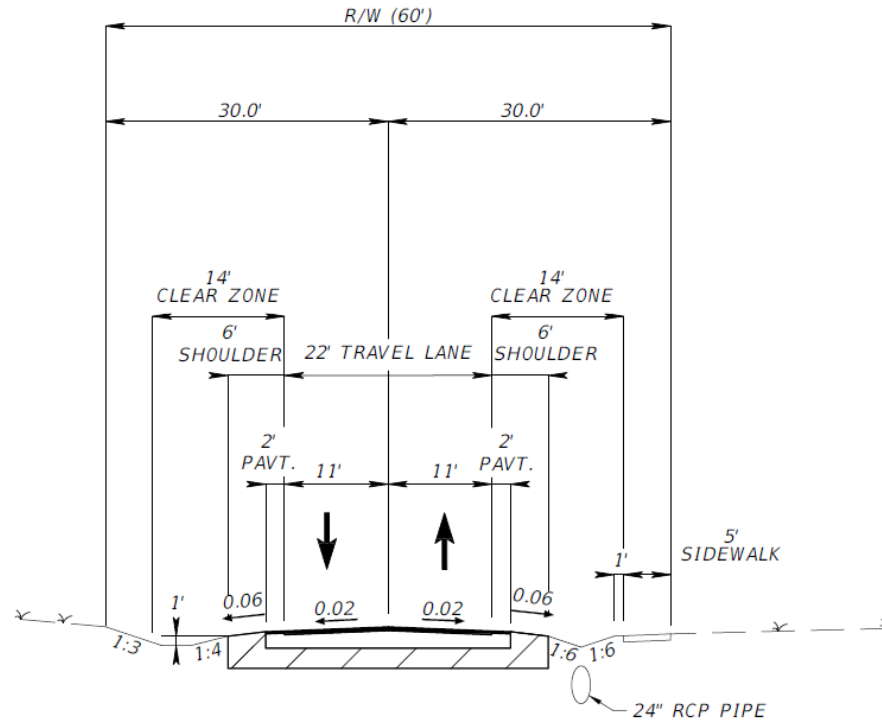

TYPICAL SECTION - 4  
CLARENCE STREET & SIDEWALK  
STA: 77+95.03 TO 85+10.28

NEW CONSTRUCTION  
2.5" SP 12.5 TRAFFIC LEVEL C  
8" THICK GRADED AGGREGATE BASE  
12" TYPE B STABILIZATION

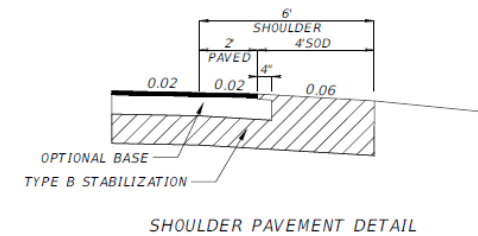

TRAFFIC DATA

CURRENT YEAR =  
ESTIMATED OPENING YEAR =  
ESTIMATED DESIGN YEAR =  
K = % D = % T = % (24 HOUR)  
DESIGN HOUR T =  
  
CONTEXT CLASS = C4  
DESIGN SPEED = 35 MPH  
POSTED SPEED = 25 MPH

REVISIONS			
DATE	DESCRIPTION	DATE	DESCRIPTION

BLAKE R. FURBEE, P.E.  
P.E. LICENSE NUMBER 88505  
GORTMOLLER ENGINEERING, INC.  
708 THOMAS DRIVE  
PANAMA CITY BEACH, FL 32408  
REGISTRY NO. 09505



CITY OF PANAMA CITY BEACH

PROJECT	COUNTY	PROJECT NO.
CLARENCE STREET	BAY	23-041

TYPICAL SECTIONS

SHEET NO.  
6

THE OFFICIAL RECORD OF THIS SHEET IS THE ELECTRONIC FILE DIGITALLY SIGNED AND SEALED UNDER RULE 61G15-23.004, F.A.C.





# Costs and Quantities



Engineer of Record “Estimated” Cost of Construction:  
\$2.5 Million



Construction Engineering Inspection: 10 - 15% of Project



Feet of Roadway: ~ 3,380 Feet, About 2/3 of a Mile



5 Foot Sidewalk Along Southern Right of Way



# Asphalt Preservation

- Crack Seal
  - Asphalt Rejuvenator (Maltene Replacement Technology)
  - Microsurfacing
  - Cape Seal
- 

# Crack Seal





# Crack Seal



# Asphalt Rejuvenator (Maltene Replacement Technology)



# Microsurfacing





# Cape Seal



# Cape Seal

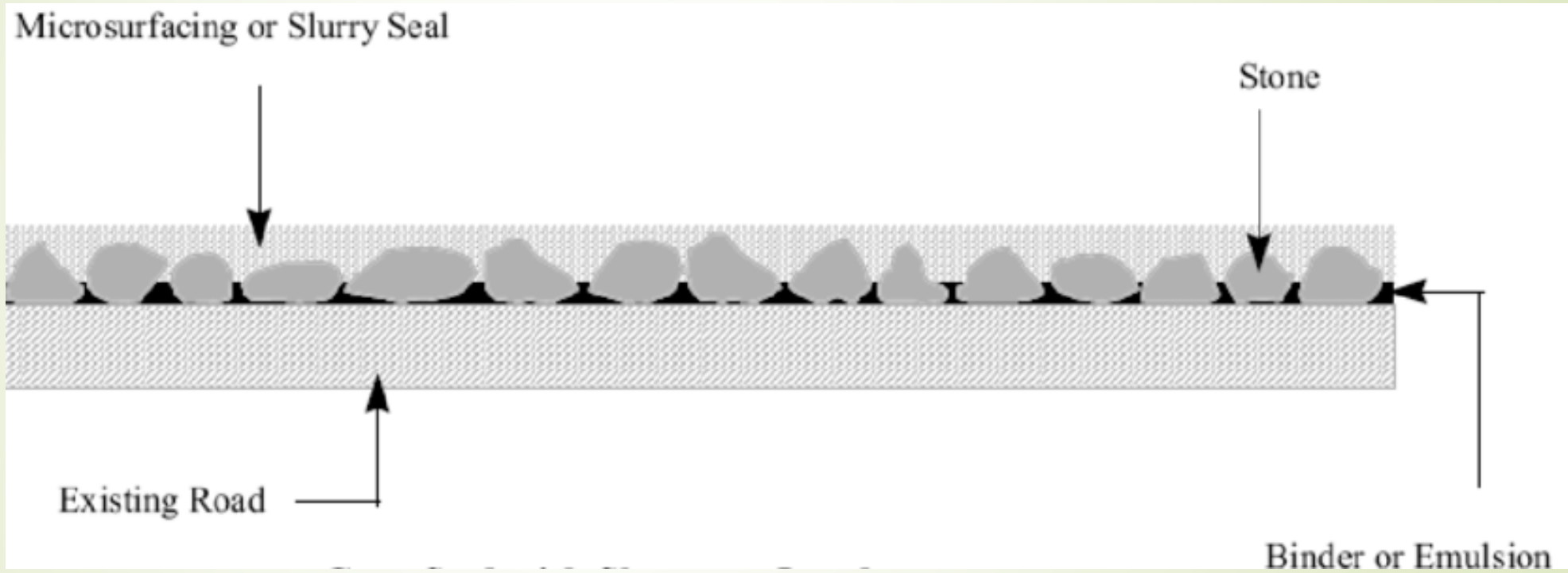





# Questions?